

TEMPORARY AND DURABLE 150 mm WHITE LINE

STA. 0+100 LT. - STA. 0+460 LT. (SOLID)
 STA. 0+100 RT. - STA. 0+460 RT. (SOLID)

REMOVAL AND DISPOSAL OF STEEL BEAM GUARDRAIL

STA. 0+443 RT. - STA. 0+460 RT.

STEEL BEAM GUARDRAIL

STA. 0+443 RT. - STA. 0+460 RT.

REHABILITATION OF DI'S, CB'S, OR MH'S-CLASS 1

STA. 0+419 LT.
 0+210 RT (2)

SNOW BARRIER-GALVANIZED

STA. 0+369 LT. - STA. 0+431 LT.
 STA. 0+369 RT. - STA. 0+431 RT.

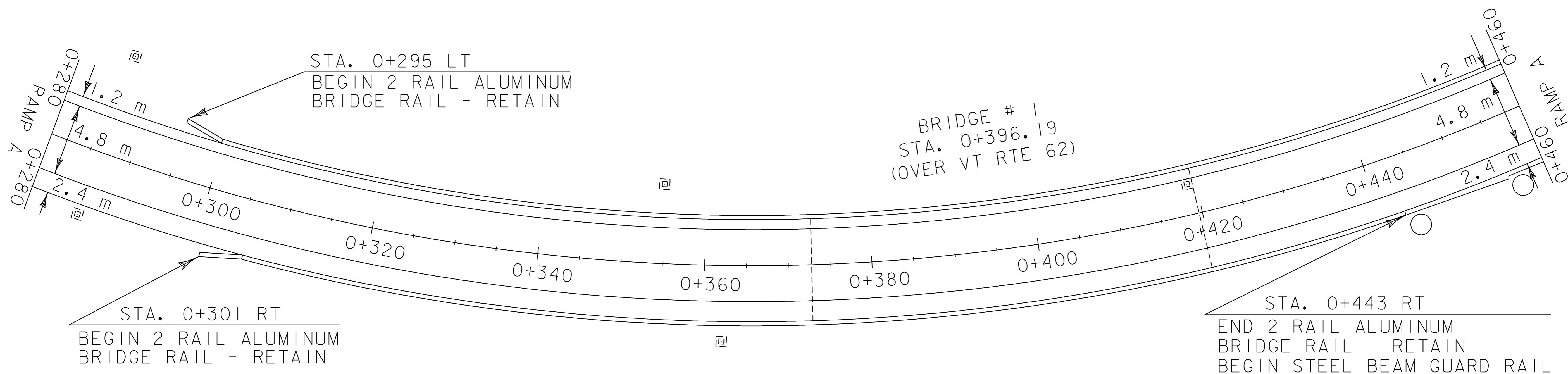

RAMP A

**PAVING
PROJECT
LAYOUT
#18**

PROJECT NAME: BERLIN-BARRE CITY
 PROJECT NUMBER: STP 232(I)S

FILE NAME: /pave/01b022/pb022.dgn
 PROJECT LEADER: WOOLAVER
 DESIGNED BY: LOCKE
 pb0221d18.1

PLOT DATE: 12-MAR-2007 11:0
 DRAWN BY: LOCKE
 CHECKED BY:
 SHEET 30 OF 39