

GENERAL SHOP NOTES

SPECIFICATIONS

- MATERIAL AND WORKMANSHIP TO BE IN ACCORDANCE WITH THE STATE OF VERMONT, AGENCY OF TRANSPORTATION, STANDARD SPECIFICATIONS FOR CONSTRUCTION DATED 2001, GENERAL SPECIAL PROVISIONS, AND THE LATEST EDITION OF AASHTO STANDARD SPECIFICATIONS FOR HIGHWAY BRIDGES.

MATERIAL

- MATERIAL SHALL CONFORM TO AASHTO M270, GRADE 50W (UN).
- MATERIAL NOTED (M270-50WT2) ON DETAIL DRAWINGS SHALL REQUIRE CHARPY V-NOTCH TESTING (ZONE 2).
- HIGH STRENGTH BOLTS SHALL CONFORM TO AASHTO M164 TYPE 3 WITH ONE AASHTO M291 HVY. HEX NUT & ONE AASHTO M293 TYPE 3 WASHER.

FABRICATION & WORKMANSHIP

- "BEARING AREA" AS NOTED ON STRINGER DETAILS, INDICATES AREA THAT MUST BE FLAT AND TRUE TO RECEIVE SOLE PLATE.
- RE-ENTRANT CUTS TO HAVE A 1" MIN. RADIUS (2" ON MAIN MEMBERS).

SHOP WELDING AND TESTING NOTES:

- WELDING AND NON-DESTRUCTIVE TESTING SHALL BE IN ACCORDANCE WITH ANSI/AASHTO/AWS BRIDGE WELDING CODE, D1.5.
- FOR WELDING CONNECTION PLATES TO BEAMS SEE "TYP. WELD TERMINATION DETAIL".

DRAWING REFERENCE:

GIRDER JOB STANDARDS - PREFIXED "X"

SHOP CLEANING NOTES:

- BLAST CLEAN ALL STEEL TO SSPC-SP10 (NEAR WHITE) AFTER FABRICATION .

SHOP PAINTING NOTES:

- NO PAINT

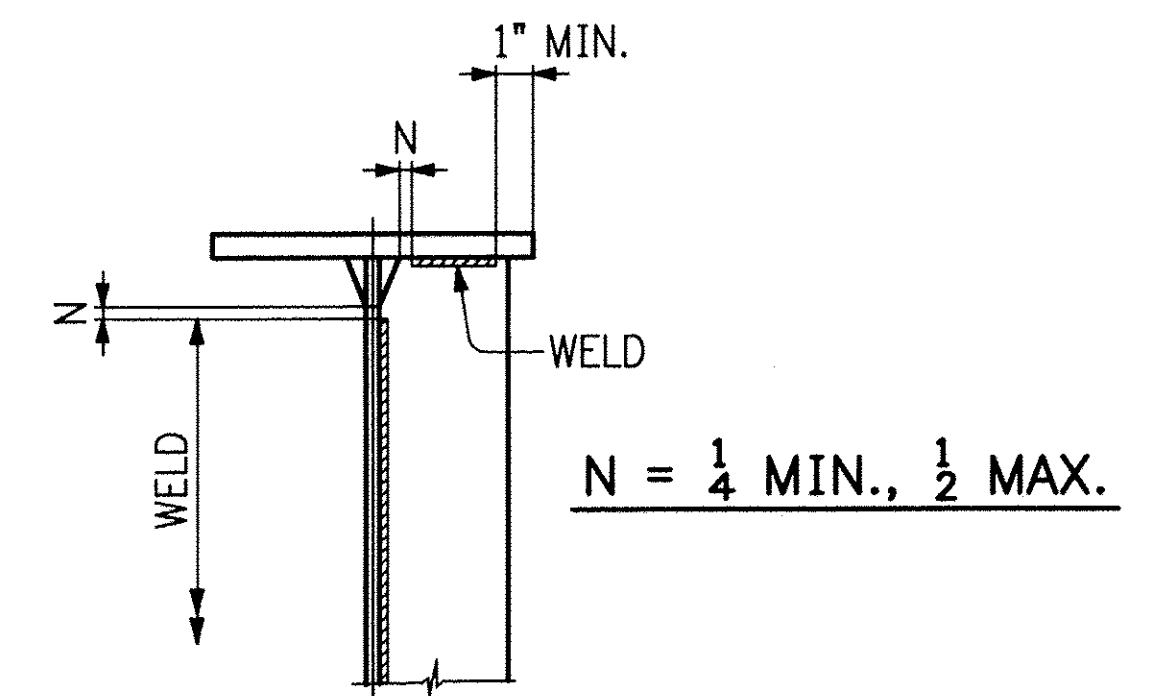

TYP. WELD TERMINATION DETAIL

REV.	DATE	DESCRIPTION	QTY.	DATE	ISSUED TO	FOR
8	3/9/06				F W Whitcomb	Approval

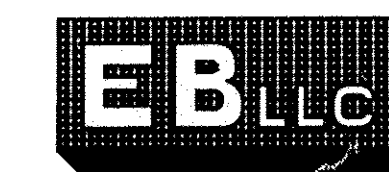

EASTERN BRIDGE LLC
RURAL RTE 2, BOX 302
CLAREMONT, NH 03743
603-542-5202

PROJECT: T.H. NO. 1 OVER SAXTONS RIVER (BRIDGE NO. 16C)	
LOCATION: PROJ. NO. TH2-0104	GRAFTON, VERMONT
ENGINEER: VANASSE HANGEN BRUSTLIN, INC.	
CUSTOMER: FRANK W. WHITCOMB CONST.	
DRAWING TITLE: GENERAL NOTES	
DRAWN BY: CPM 3-3-06	JOB NUMBER: 6065
CHECKED BY: [Signature] 3-6-06	SHEET NUMBER: GN1