

R8-3A

COLORS:
CIRCLE AND DIAGONAL - RED (RETROREFL)
SYMBOL AND BORDER - BLACK (NON - REFL)
BACKGROUND - WHITE (RETROREFL)

SIGN	DIMENSIONS (INCHES)										
	A	B	C	D	E	F	G	H	J	K	L
URBAN MIN. AND STD.	12	3/8	3/8	3	6E(M)	4 7/8	3 7/8	1	1 1/2		
RURAL MIN. AND STD.	24	3/8	5/8	6	12E(M)	10 1/2	8 1/2	2	1 1/2		
EXPWY.	36	3/8	7/8	9	18E(M)	15 3/4	12 3/4	3	2 1/4		
FWY.	48	3/4	1 1/4	12	24E(M)	21	17	4	3		

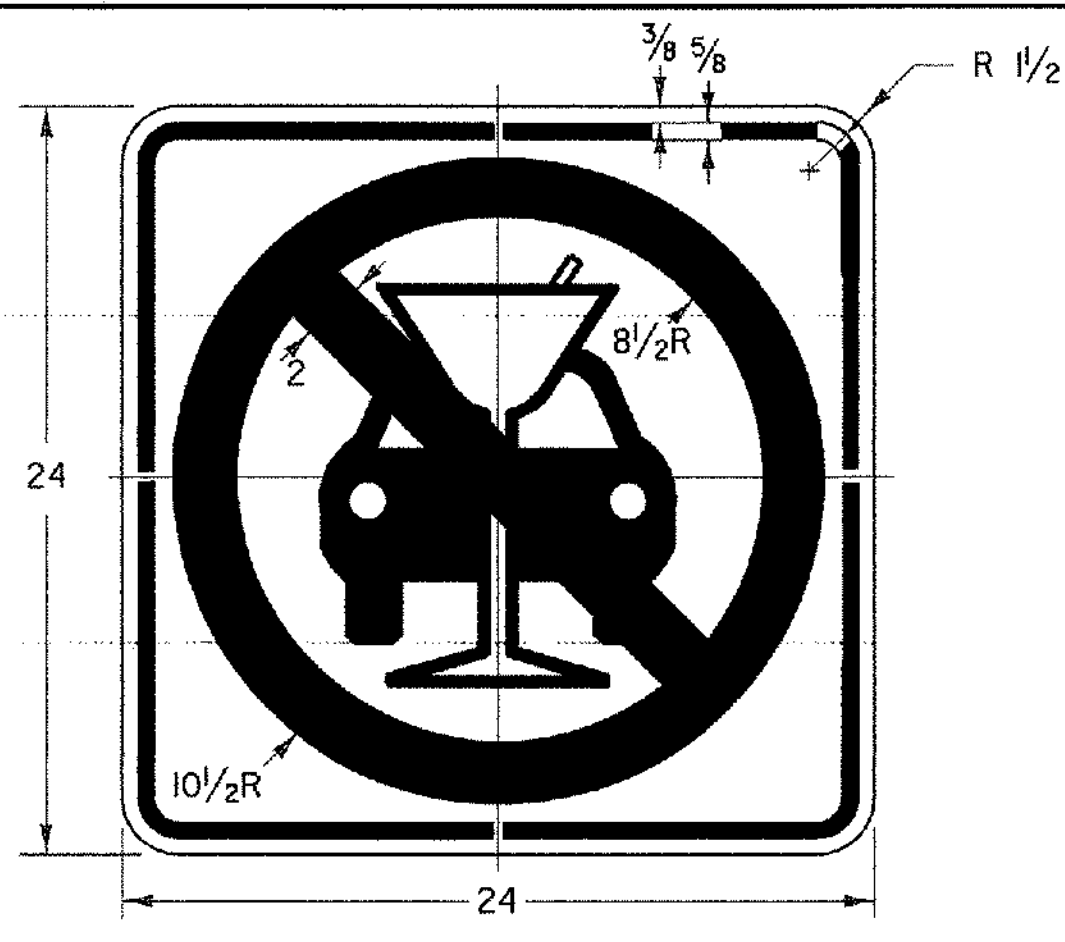

VR-654

COLORS:
CIRCLE AND DIAGONAL - RED (RETROREFL)
SYMBOL AND BORDER - BLACK (NON - REFL)
BACKGROUND - WHITE (RETROREFL)

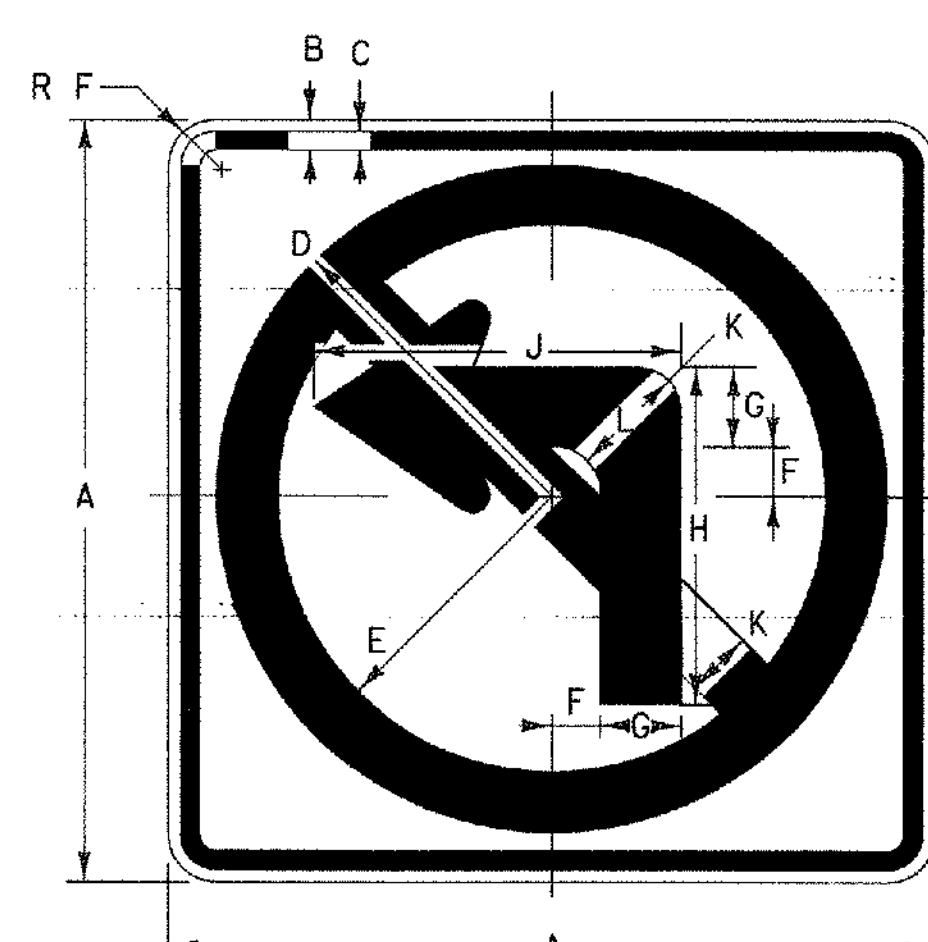
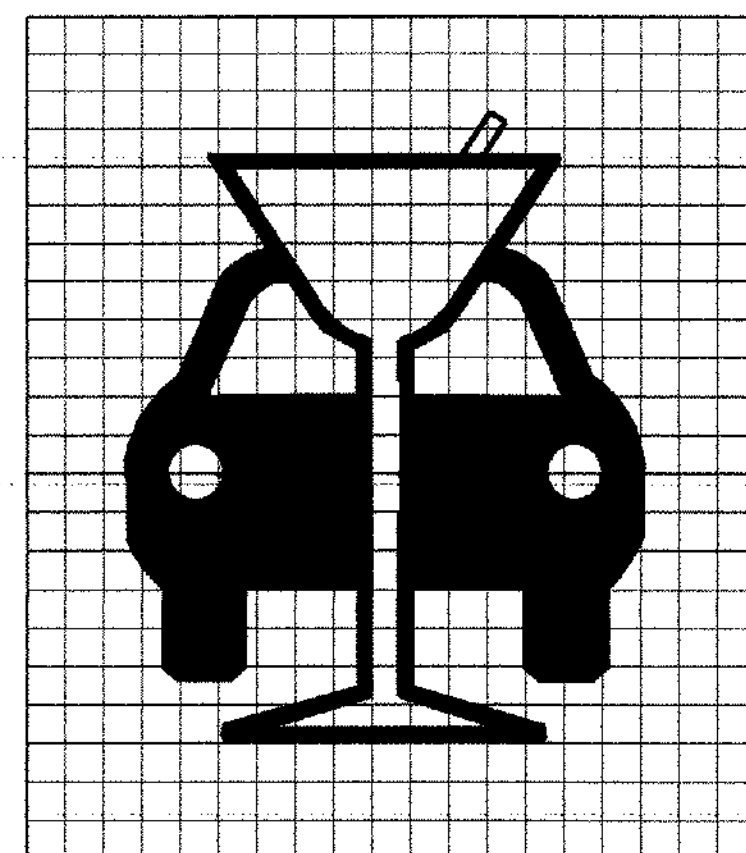

R3-2

COLORS:
SYMBOL - RED (RETROREFL)
LEGEND AND BACKGROUND - WHITE (RETROREFL)

SIGN	DIMENSIONS (INCHES)										
	A	B	C	D	E	F	G	H	J	K	L
MIN. AND STD.	30	6 1/2	4D	2	5	14 1/2	12 1/2	9 3/4	10	1 7/8	7 7/8
EXPWY.	36	7 1/2	5D	2 1/2	6	17 1/2	15	12	12 3/8	2 1/4	9 9/16
SPECIAL	48	8 1/2	6D	3	8	23 1/2	20	14 1/2	15	3	11 3/4

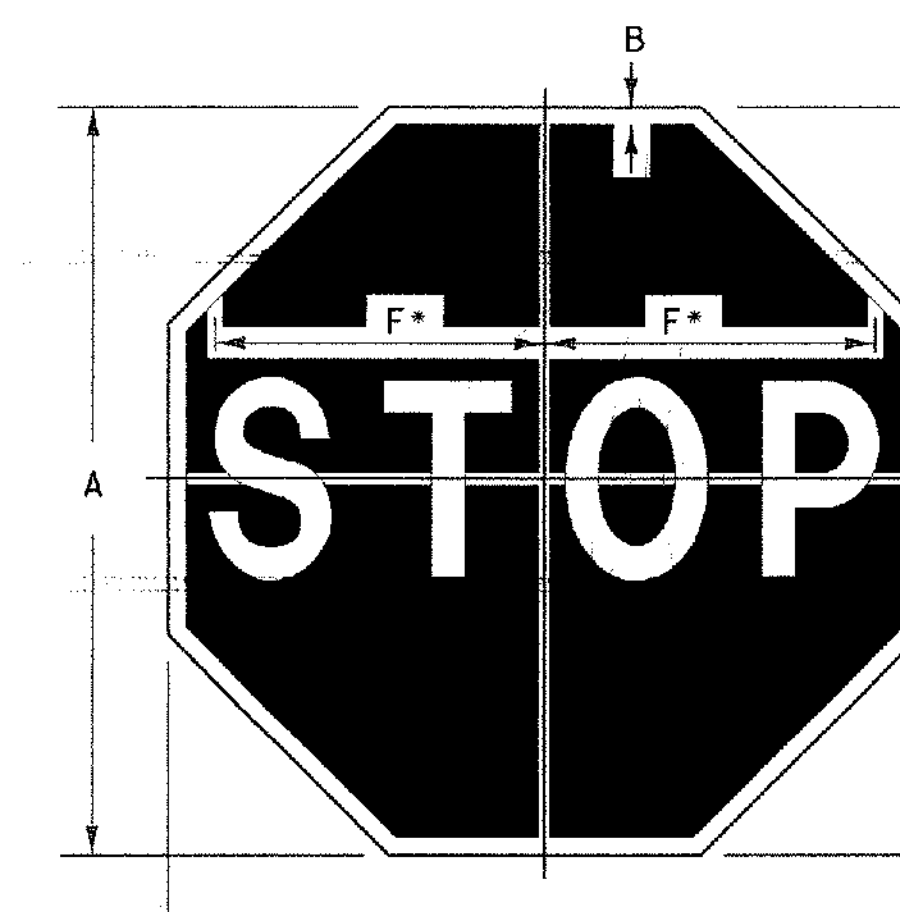

R1-1

* REDUCE SPACING 40 %

COLORS:
LEGEND - WHITE (RETROREFL)
BACKGROUND - RED (RETROREFL)

SIGN	DIMENSIONS (INCHES)					
	A	B	C	D	E	F
PATH	18	3/8	6	6C	3	7 3/4
MIN.	24	3/8	8	8C	4	10
STD.	30	3/4	10	10C	5	12 1/2
EXPWY.	36	3/8	12	12C	6	15
SPECIAL	48	1 1/4	16	16C	8	20

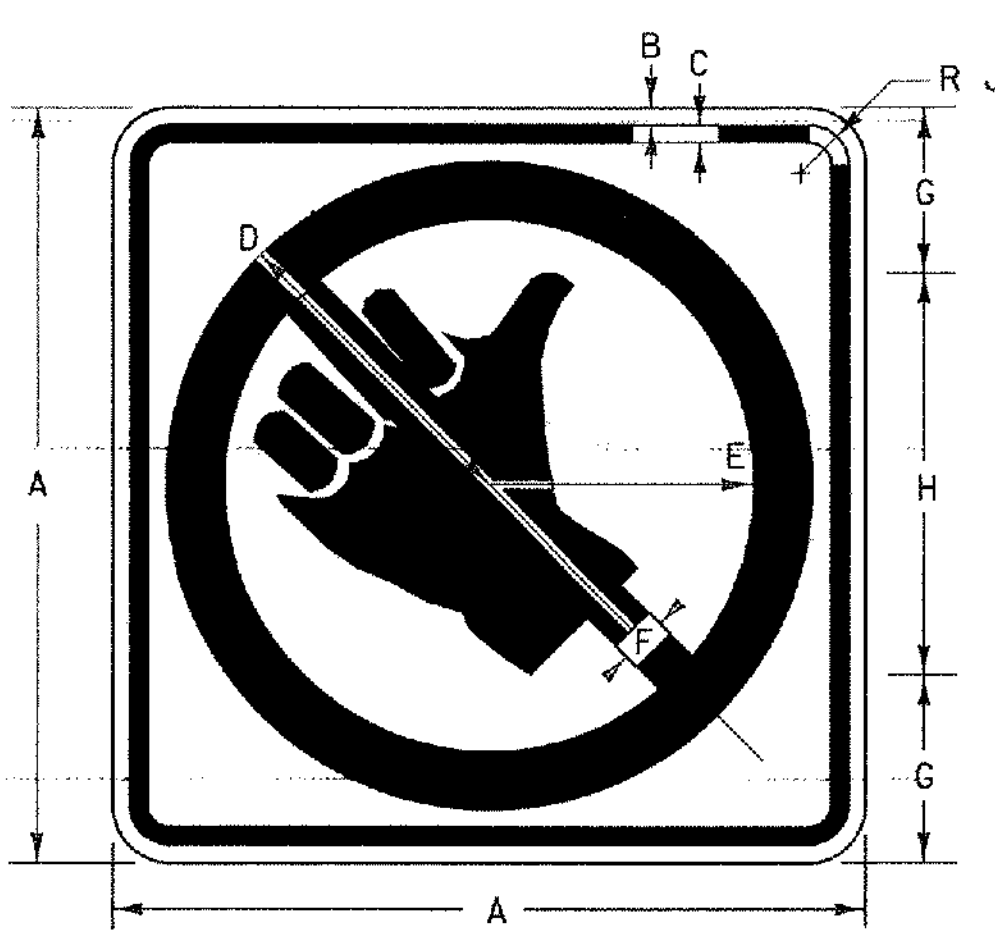

R9-4A

COLORS:
CIRCLE AND DIAGONAL - RED (RETROREFL)
SYMBOL AND BORDER - BLACK (NON - REFL)
BACKGROUND - WHITE (RETROREFL)

SIGN	DIMENSIONS (INCHES)										
	A	B	C	D	E	F	G	H	J	K	L
MIN.	18	3/8	5/8	7 7/8	6 3/8	1 1/2	3 3/4	10 1/2	1 1/2		
STD.	24	3/8	5/8	10 1/2	8 1/2	2	5	14	1 1/2		

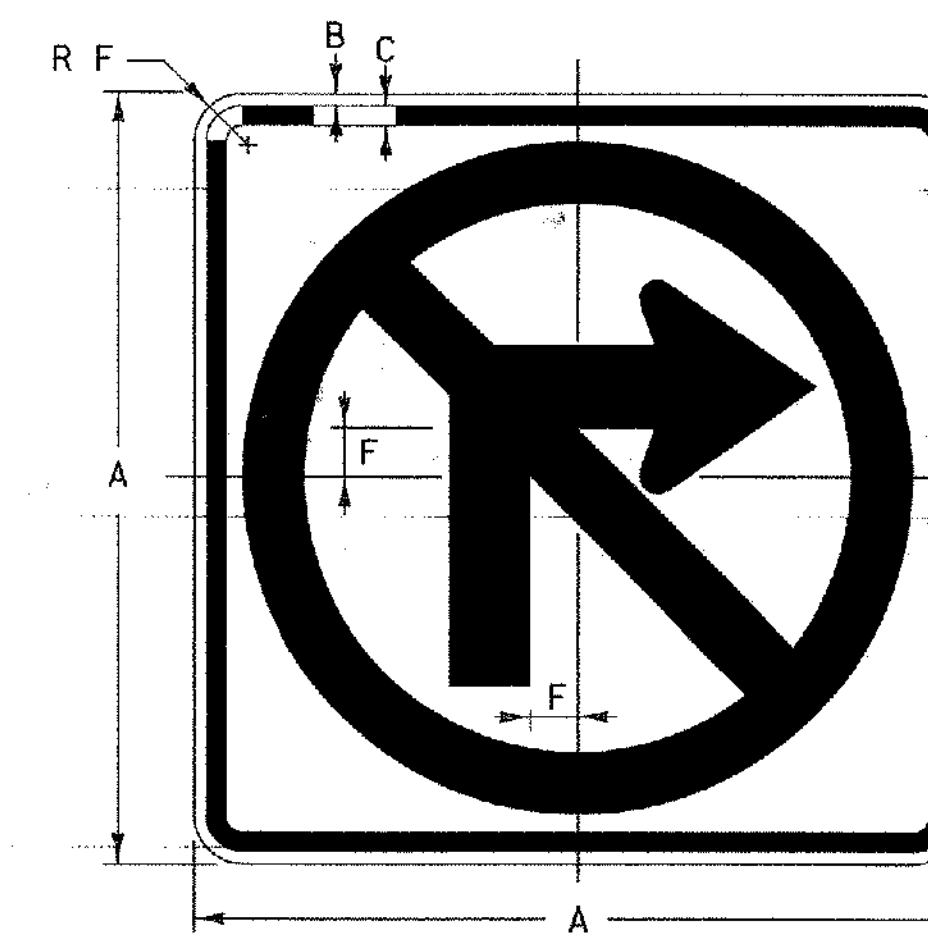
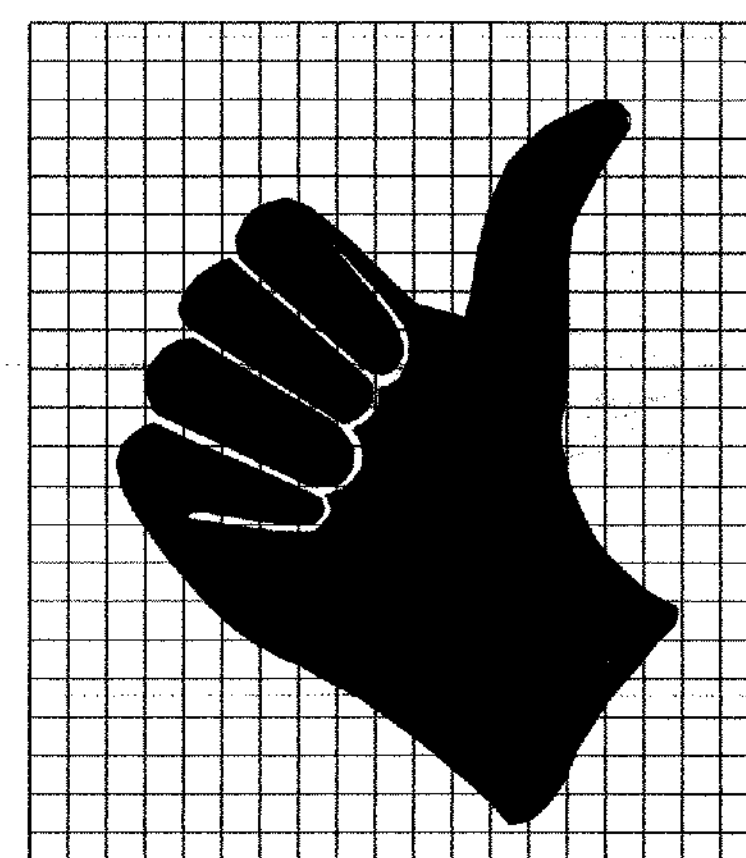

R3-1

NOTE:
SEE STANDARD E-151 FOR ARROW DETAIL
USE SAME ARROW DETAIL FOR R3-1 AND R3-2

COLORS:
CIRCLE AND DIAGONAL - RED (RETROREFL)
ARROW AND BORDER - BLACK (NON - REFL)
BACKGROUND - WHITE (RETROREFL)

SIGN	DIMENSIONS (INCHES)										
	A	B	C	D	E	F	G	H	J	K	L
MIN. AND STD.	24	3/8	5/8	10 1/2	8 1/2	1 1/2	2 1/2	10 1/2	1 1/2	2	1 1/2
SPECIAL	30	1/2	3/4	13 1/8	10 5/8	1 7/8	3 1/8	13 1/8	1 1/2	2 1/2	5/8
EXPWY.	36	5/8	7/8	15 3/4	12 3/4	2 1/4	3 3/4	15 3/4	1 7/4	3	3/4
SPECIAL	48	3/4	1 1/4	21	17	3	5	21	2 3/4	4	1

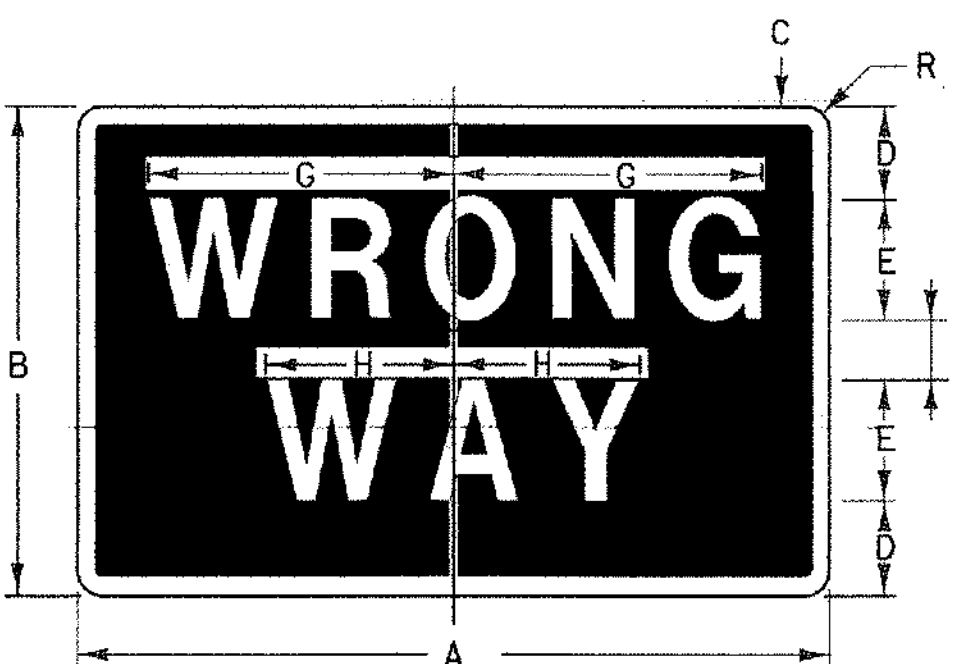

R5-1A

COLORS:
LEGEND - WHITE (RETROREFL)
BACKGROUND - RED (RETROREFL)

SIGN	DIMENSIONS (INCHES)										
	A	B	C	D	E	F	G	H	J	K	L
STD.	36	24	3/4	4 1/2	6D	3	13 3/8	8 1/16	1 1/2		
SPECIAL	42	30	7/8	5	8D	4	17 3/4	10 3/4	1 7/8		

(ALL DIMENSIONS SHOWN IN INCHES EXCEPT WHERE NOTED)

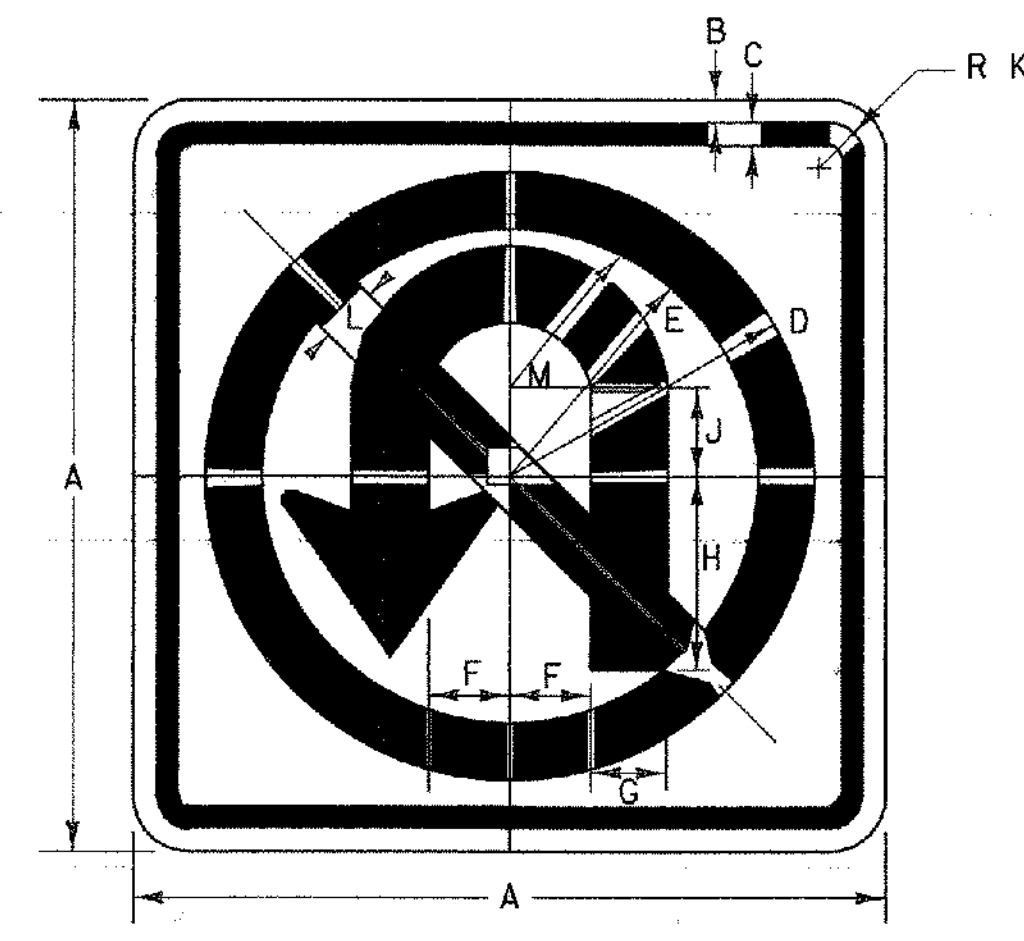

R3-4

SEE STANDARD E-151 FOR ARROW DETAIL

COLORS:
CIRCLE AND DIAGONAL - RED (RETROREFL)
ARROW AND BORDER - BLACK (NON - REFL)
BACKGROUND - WHITE (RETROREFL)

SIGN	DIMENSIONS (INCHES)										
	A	B	C	D	E	F	G	H	J	K	L
MIN. AND STD.	24	3/8	5/8	10 1/2	8 1/2	2 1/2	2 1/2	6	2 1/4	1 1/2	2
SPECIAL	30	1/2	3/4	13 1/8	10 5/8	3 3/8	3 1/8	7 1/2	2 1/8	1 7/8	2 1/2
EXPWY.	36	5/8	7/8	15 3/4	12 3/4	3 3/4	3 3/4	9	3 3/8	2 1/4	3
SPECIAL	48	3/4	1 1/4	21	17	5	5	12	4 1/2	3	4

REVISIONS AND CORRECTIONS

OCT. 30, 1987 - DATE OF ORIGINAL ISSUE
SEPT. 20, 1995 - ADDED AND DELETED SIGN DETAILS, ADDED SIGN ID NUMBERS, MINOR NOTE REVISIONS.
JUNE 15, 2004 - CHANGED REFLECTIVE SHEETING TO TYPE III OR TYPE VIII

APPROVED

[Signature]
DIRECTOR OF PROGRAM DEVELOPMENT
[Signature]
TRAFFIC OPERATIONS ENGINEER
[Signature]
FEDERAL HIGHWAY ADMINISTRATION

**REGULATORY SIGN
DETAILS**



**STANDARD
E-143**

**OTHER STDS. E-144, E-151
REQUIRED:**