

G20-4

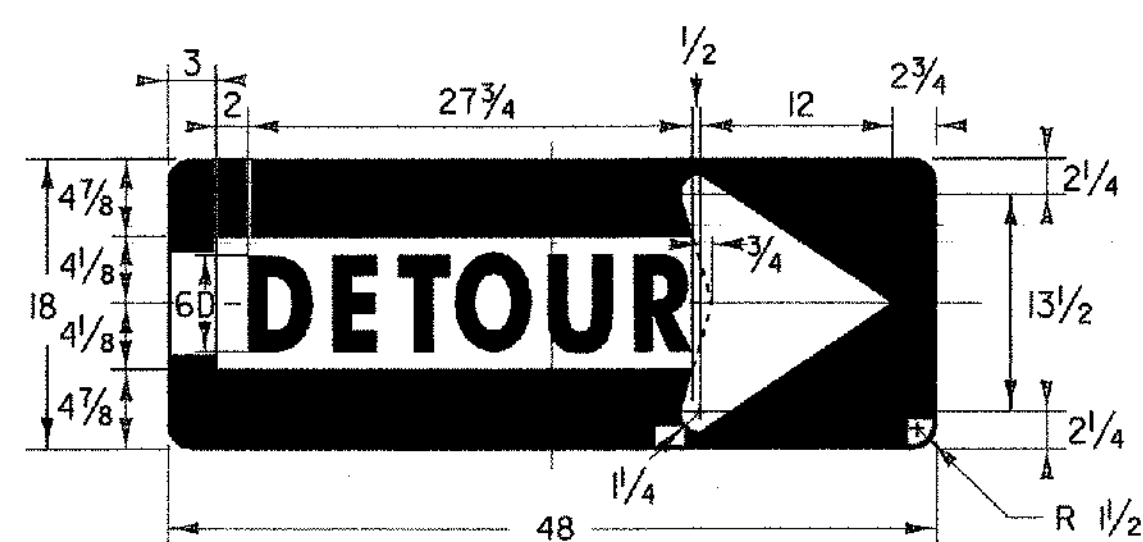

M4-10(R)

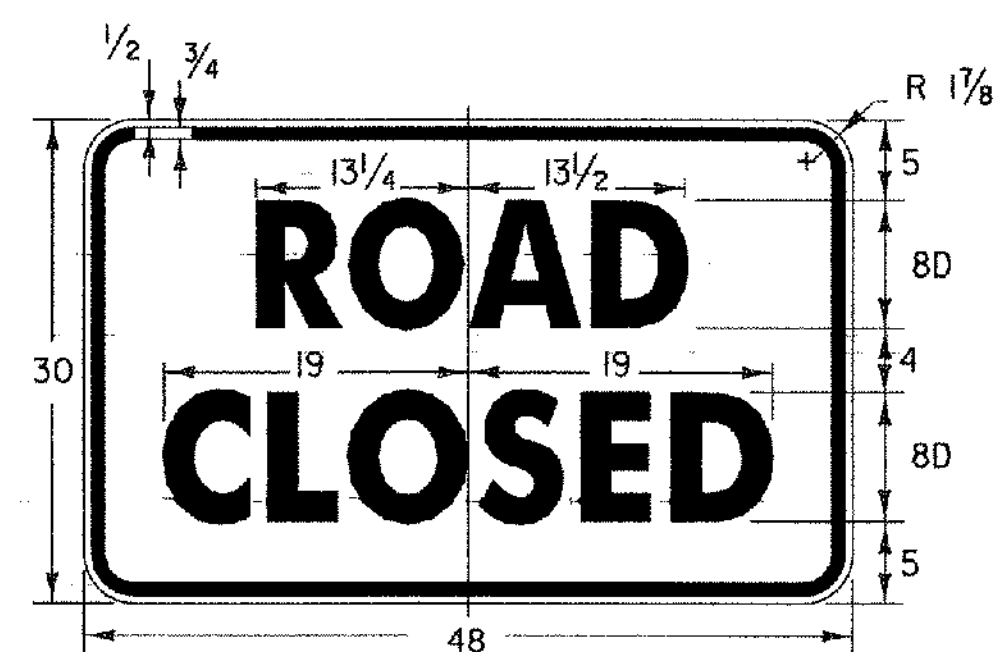

R11-2

COLORS:
BLACK TEXT AND BORDER
WHITE RETROREFLECTORIZED BACKGROUND

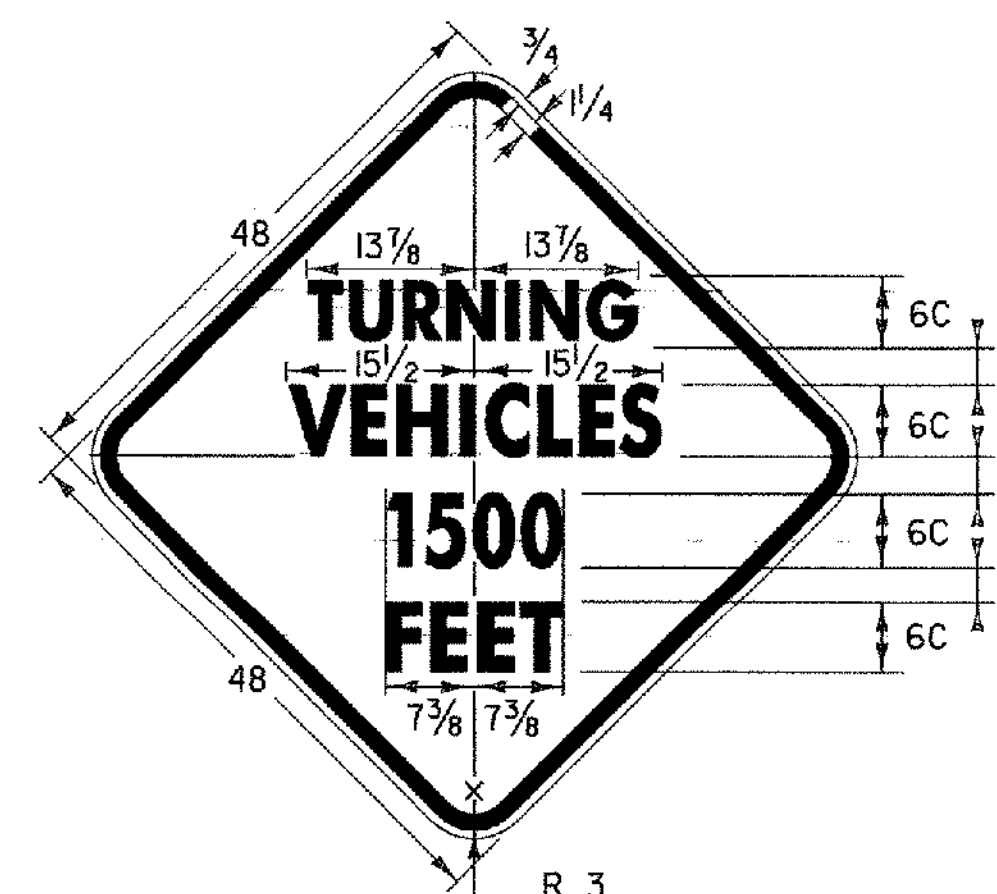

VC-001

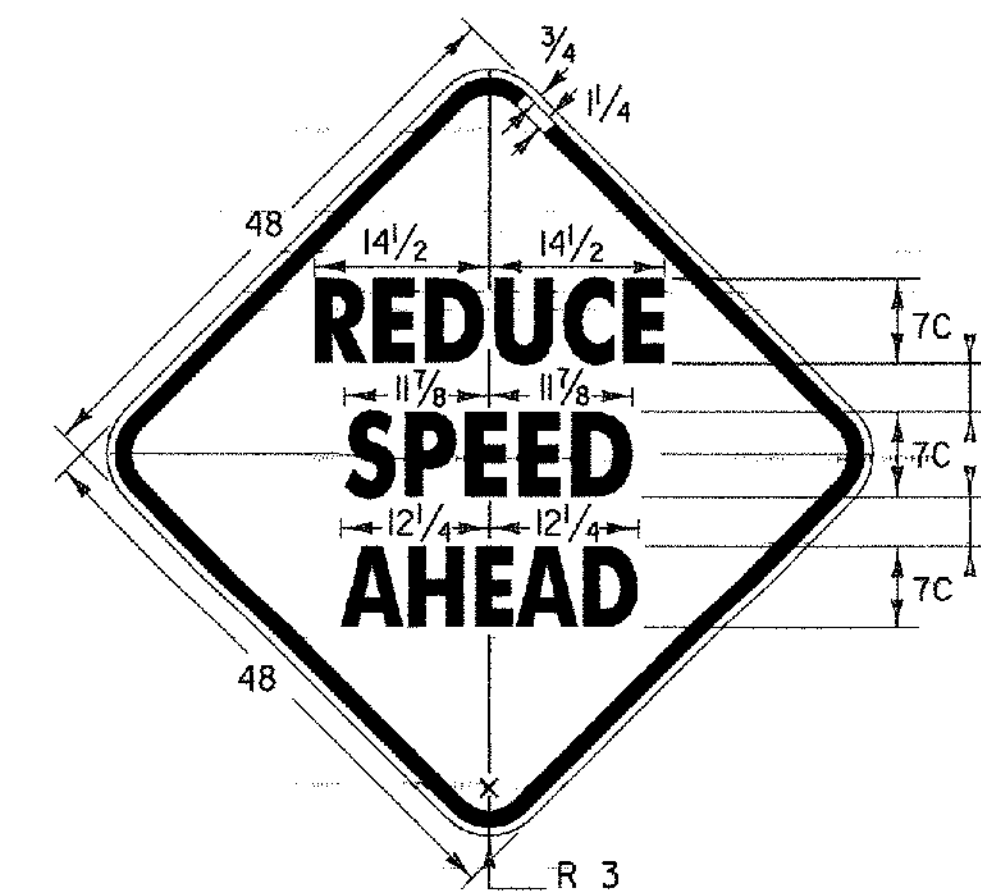

VC-002

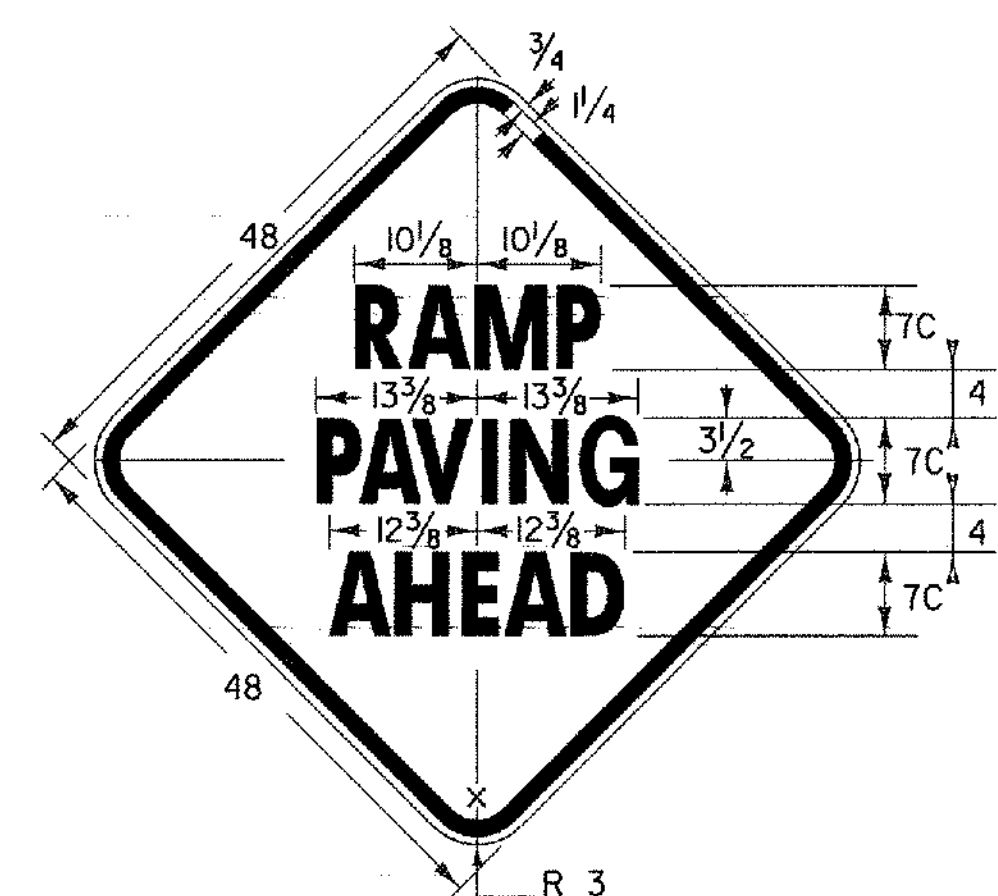

VC-003

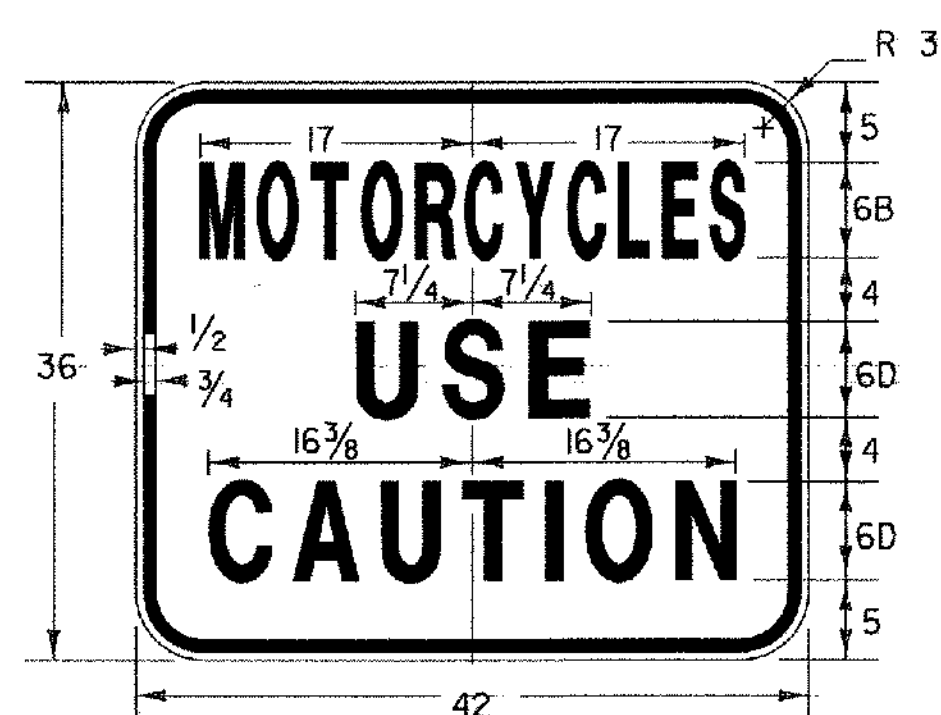

VC-004

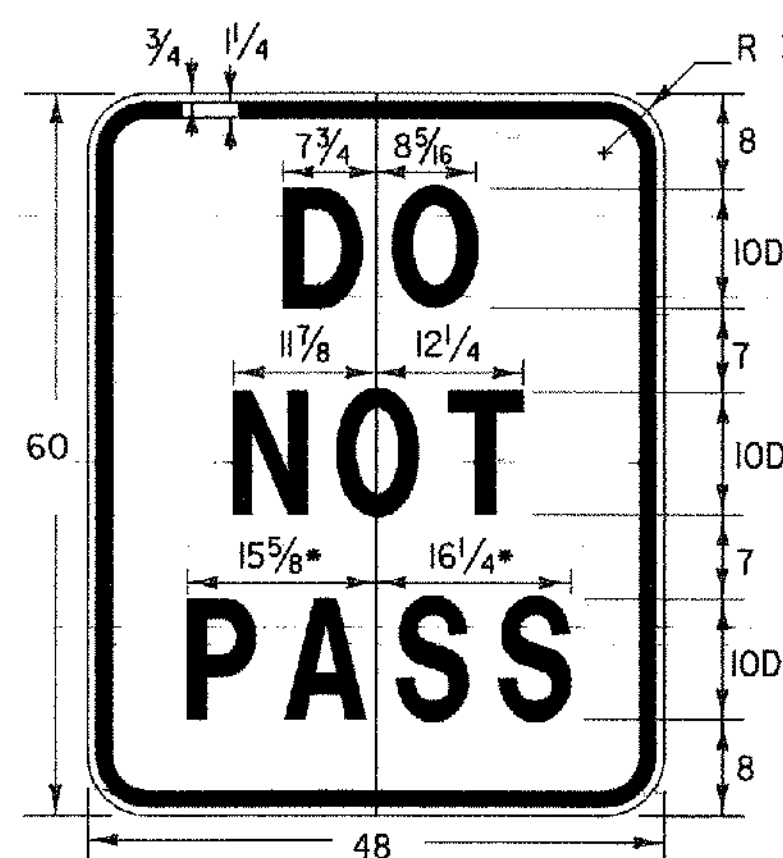

VC-005

* REDUCE SPACING BY 40%

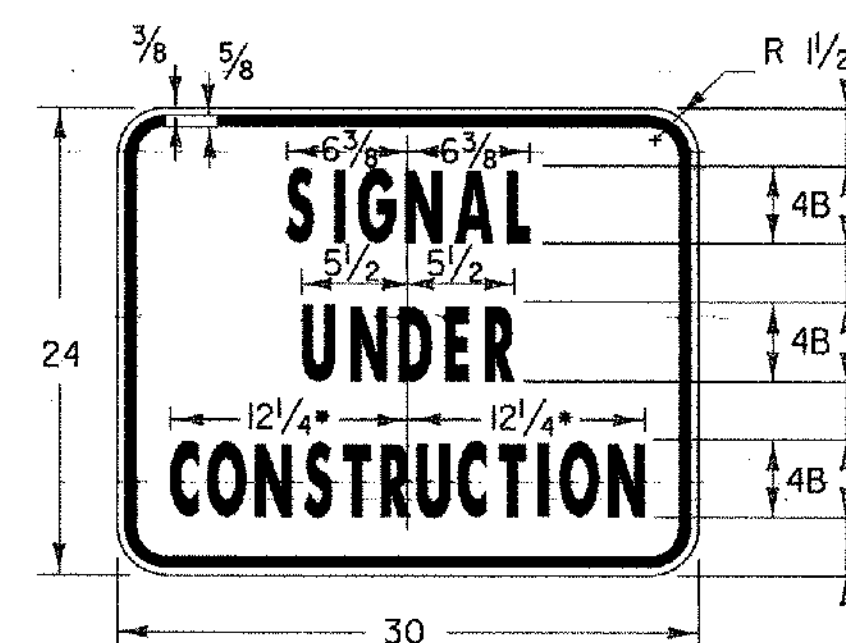

VC-820

* REDUCE SPACING 25%

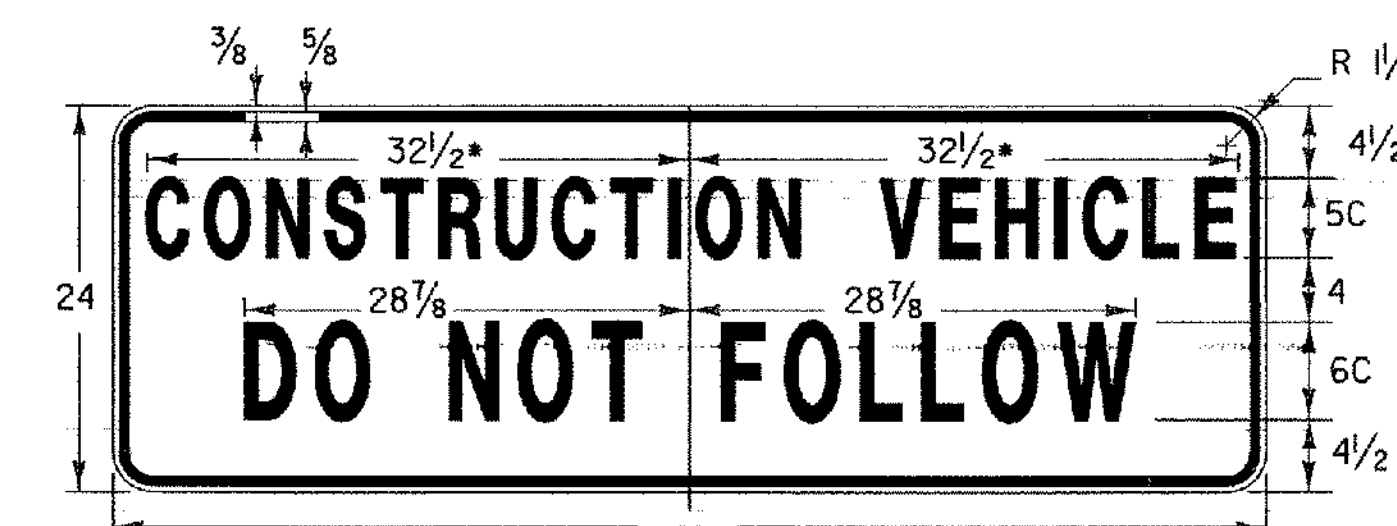

VC-007

* REDUCE SPACING 20%

IT IS SUGGESTED THAT THIS SIGN BE DESIGNED TO FOLD, (DOWN OR ACROSS), BE COVERED, OR BE REMOVED WHEN NOT IN USE. THE SIGN SHOULD ALSO BE MOUNTED AS TO NOT INTERFERE WITH THE VISIBILITY OF DIRECTIONAL OR TAIL LIGHTS AS REQUIRED BY LAW.

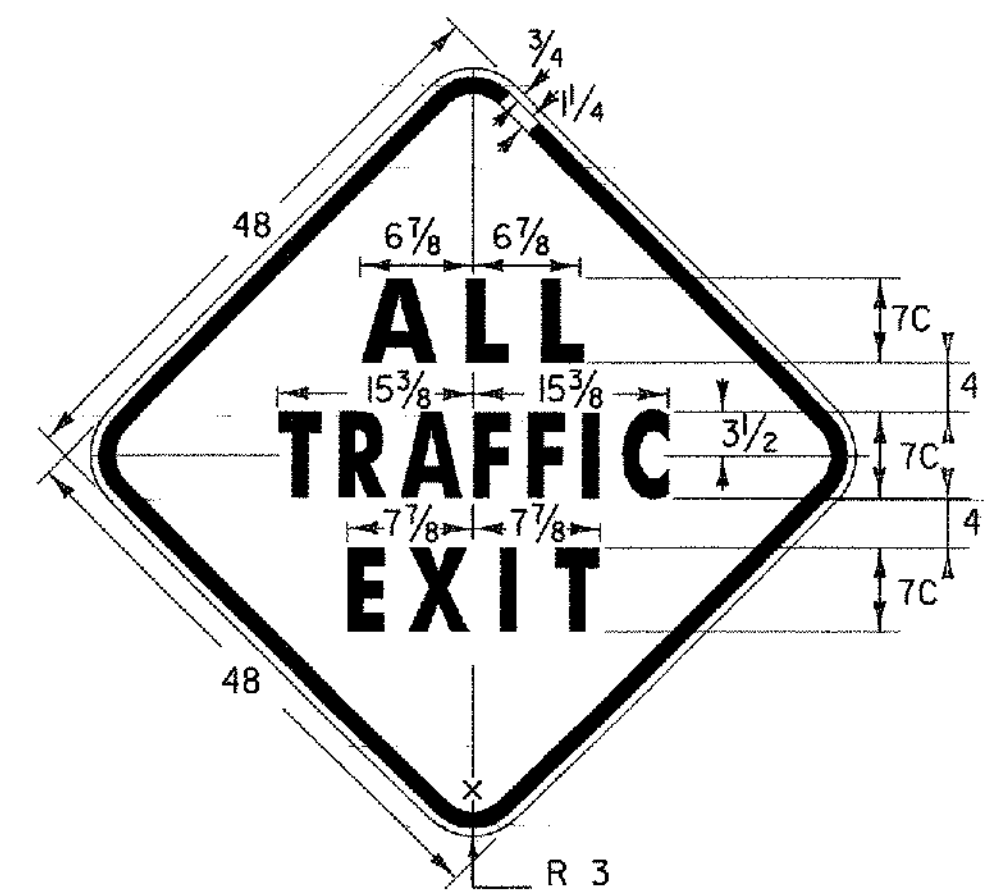

VC-008

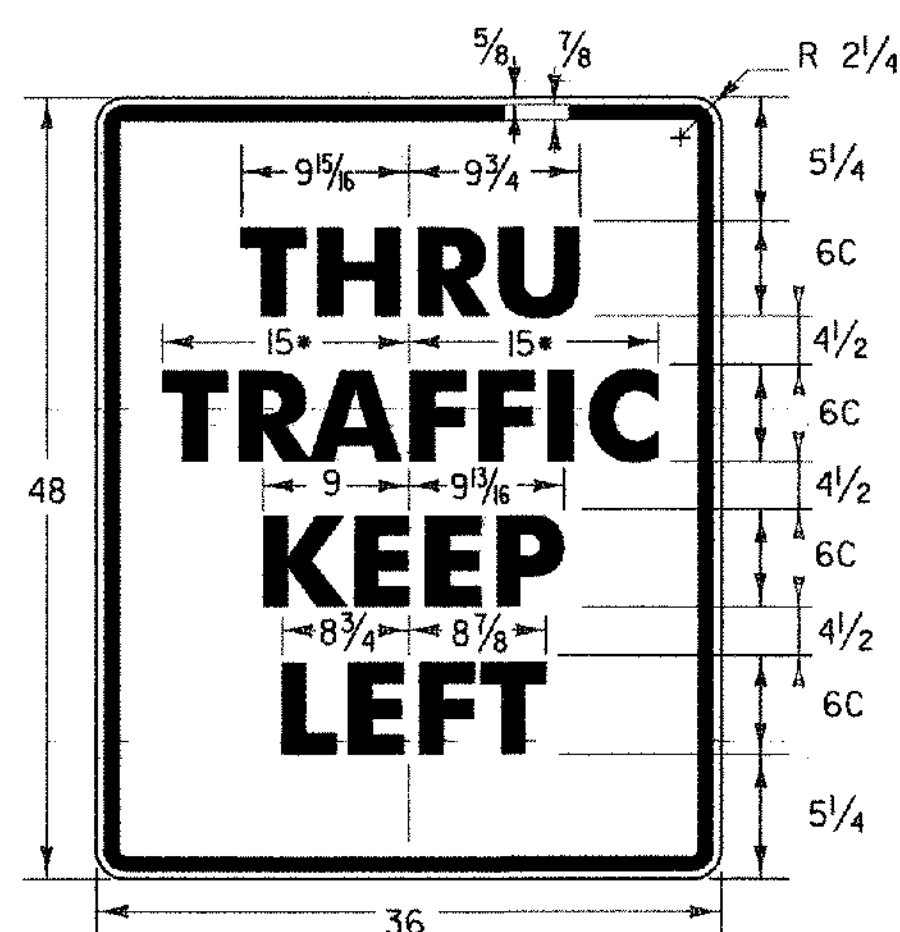

VR-118L

* REDUCE SPACING 25 %

COLORS:
BLACK TEXT AND BORDER
WHITE (RETROREFLECTORIZED) BACKGROUND

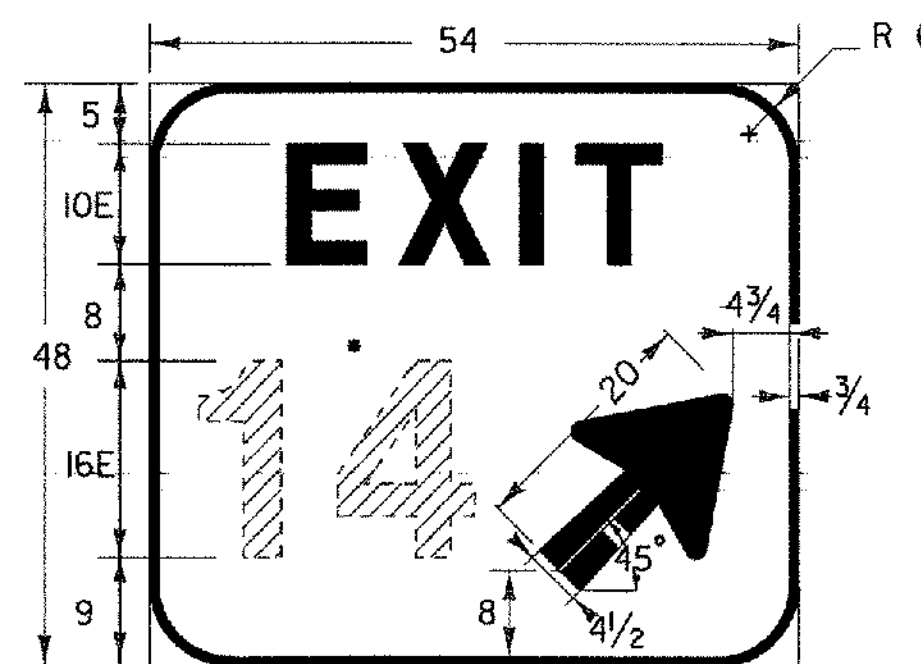

E5-1a

* EXIT NUMBER AS PER PLANS OPTICALLY SPACED

COLORS:
WHITE RETROREFLECTORIZED BORDER, ARROW AND LEGEND
GREEN RETROREFLECTORIZED BACKGROUND

(ALL DIMENSIONS SHOWN IN INCHES EXCEPT WHERE NOTED)

NOTES

SEE STANDARD SHEET E-100 FOR NOTES AND TEXT DETAILS
COLORS FOR SIGNS SHOWN ON THIS SHEET SHALL BE BLACK TEXT, BORDER AND SYMBOLS ON ASTM TYPE III OR TYPE VIII RETROREFLECTIVE ORANGE BACKGROUND, UNLESS OTHERWISE NOTED.
SIGN DETAILS INDICATE THE PROPER COLOR.

OTHER STDS. E-100, E-151 REQUIRED:

REVISIONS AND CORRECTIONS

AUG 08, 1995 - DATE OF ORIGINAL ISSUE
MAY 01, 2004 - CHANGED REFLECTIVE SHEETING TO TYPE III

APPROVED

[Signature]
DIRECTOR OF PROGRAM DEVELOPMENT
[Signature]
TRAFFIC OPERATIONS ENGINEER
[Signature]
FEDERAL HIGHWAY ADMINISTRATION

**CONSTRUCTION SIGN
DETAILS**

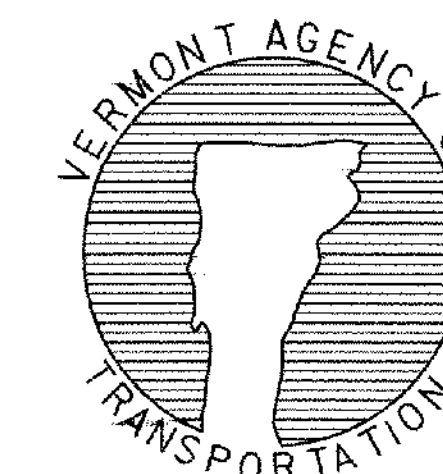

**STANDARD
E-102A**