

DSBROWN Production Joint Welding Procedure Specification (D1.5-08)

Procedure No: B-FF-01 Date Issued: 3-28-08 Revision No: 01 Rev. Date: 11-11-09
 Contractor (Fabricator) D. S. Brown Company Prepared by: Brad Streeter, Quality Assurance Manager

1. Non-Fracture Critical Fracture Critical WPS Expiration Date: 3-6-13
2. Qualified in accordance with: AWS D1.5-2008 (5.13)
 Referenced PQR No(s): PQR-FCAW-01-(08)
 Referenced FWST No(s): PQR-FCAW-FWST-01A(08), PQR-FCAW-FWST-01B(08)
3. Material specification(s) ASTM A709 Gr. 36, 50, 50W For DOT Approval
4. Material Thickness (es) Unlimited
5. Welding process FCAW
6. Manual , machine , or semiautomatic
7. Position(s) of welding 1F, 2F
8. Filler metal specification AWS A5.20
9. Filler metal class and brand name E71T-1CH8 (UltraCore71C)
10. Flux class & brand N/A, Type N/A
11. Shielding gas 100% CO2 Flow rate 45 CFH
12. Single pass Or multiple pass
13. Single arc Or multiple arc
14. Welding Current DCEP
15. Polarity Reverse
16. Welding progression stringers
17. Root treatment Clean to bright sound metal or per AWS D1.5 (3.2.1 & 3.11)
18. Postheat treatment N/A
19. Calculated Heat Input (KJ/in) Min 32.2 KJ/in Max 45.8 KJ/in
20. Electrode extension (electrical stickout) 3/4"

VTrans Received OK by: JTW
 FEB 28 2012
 Approved by: [Signature]

Weld size (in)	Pass No(s)	Electrode Size (in)	Welding Process Variables		Travel Speed (IPD)
			AMPS/WFS*	VOLTS	
**1/4"	1	1/16"	257-295	26.1-29.5	11.4-12.5
5/16"	1	1/16"	257-295	26.1-29.5	11.4-12.5
3/8"	2-3	1/16"	257-295	26.1-29.5	11.4-12.5
7/16"	3-5	1/16"	257-295	26.1-29.5	11.4-12.5
1/2"	4-6	1/16"	257-295	26.1-29.5	11.4-12.5
5/8"	5-7	1/16"	257-295	26.1-29.5	11.4-12.5
3/4"	6-8	1/16"	257-295	26.1-29.5	11.4-12.5

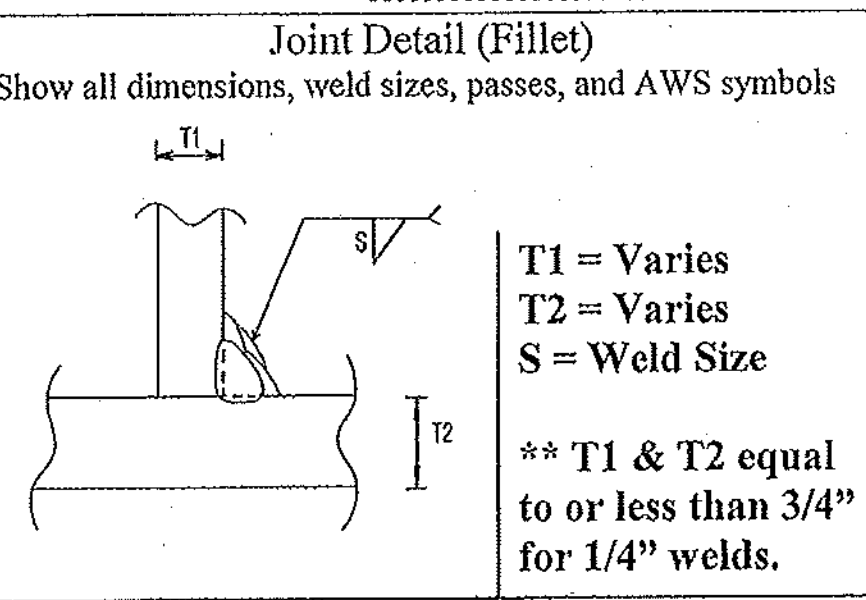

* Wire feed speed may be used along with amperage (include chart)

Prepared By: [Signature] DSB QA Manager

Project: _____

DSB Job: 35029-1112

Base Metal Thickness range	Minimum Preheat (°F)	Max Preheat & Interpass (°F)
≤ 3/4"	50°F	450°F
>3/4" to ≤1.5"	70°F	450°F
>1.5" to ≤2.5"	150°F	450°F
>2.5"	225°F	450°F

Note: When this procedure is used for A709Gr50W materials, it shall be limited to 5/16" single pass or material be coated.