

**DRAINAGE NOTES (CONT'D)**

- 40 STA 10+500, LT 4.8 m - STA 10+428, LT 4.8 m  
450 x 69.6 m PCCSP, CAAP, OR CPEP  
RC - CB WITH GRATE, TYPE E AT STA 10+500, LT 4.8 m  
RIM EL. = 89.969  
INV. IN (E) = 88.111  
INV. IN (N) = 88.111  
INV. OUT (S) = 88.035
- 41 STA 10+500, RT 4.8 m - LT 4.8 m  
450 x 8.7 m PCCSP, CAAP, OR CPEP  
RC - DI WITH GRATE, TYPE E AT  
STA 10+500, RT 4.8 m  
RIM EL. = 90.192  
INV. OUT (W) = 88.363
- 42 STA 10+474, LT 12.6 m - LT 15.6 m  
REMOVE EXISTING CB  
REMOVE EXISTING 305 x 2.4 m PIPE
- 43 STA 10+566, LT 4.8 m - STA 10+500, LT 4.8 m  
450 x 63.3 m PCCSP, CAAP, OR CPEP  
RC - DI WITH GRATE, TYPE E AT STA 10+566, LT 4.8 m  
RIM EL. = 94.987  
INV. IN (N) = 92.987 (150 UND)  
INV. IN (E) = 92.930  
INV. IN (S) = 92.627  
INV. OUT (S) = 92.551
- 44 STA 10+541, LT 4.7 m - STA 10+543, LT 6.7 m  
REMOVE EXISTING CB  
REMOVE EXISTING 305 x 2.2 m PIPE
- 45 STA 10+566, RT 4.8 m - LT 4.8 m  
450 x 9.0 m RCP (111), CAAP, PCCSP OR CPEP (SL)  
RC - DI WITH GRATE, TYPE E AT STA 10+566, RT 4.8 m  
RIM EL. = 94.955  
INV. IN (N) = 92.955 (150 UND)  
INV. OUT (W) = 92.879
- 46 STA 10+620, LT 5.5 m - STA 10+566, LT 4.8 m  
450 x 54.4 m RCP (111), CAAP, PCCSP, OR CPEP (SL)  
RC - DI WITH GRATE, TYPE E AT STA 10+620, LT 5.5 m  
RIM EL. = 96.440  
INV. IN (E) = 94.626  
INV. OUT (S) = 94.950
- 47 STA 10+615, LT 5.3 m - STA 10+566, LT 4.8 m  
150 x 49.9 m UNDERDRAIN  
INV. AT STA 10+615 = 94.418  
FLUSHING BASIN, +615, RT 5.3 m
- 48 STA 10+620, RT 5.3 m - STA 10+566, RT 4.8 m  
150 x 53.9 m UNDERDRAIN  
INV. AT STA 10+620 = 94.468  
FLUSHING BASIN, +620, RT 5.3 m
- 49 STA 10+622, RT 4.8 m - 10+620, LT 5.5 m  
450 x 9.9 m RCP (111), CAAP, PCCSP, OR CPEP (SL)  
RC - DI WITH GRATE, TYPE E AT STA 10+622, RT 4.8 m  
RIM EL. = 96.488  
INV. OUT (W) = 94.812

**SEWER NOTES**

- S1 STA 10+387, RT 22.6 m (BY OTHERS)  
PRC - SMH WITH COVER, CONST. OVER EXISTING SEWER  
RIM EL. = 73.90 +/-  
EXIST. INV. IN (W) = 71.57 +/-  
INV. IN (N) = 71.642  
EXIST. INV. OUT (E) = 71.55 +/-  
CONTRACTOR TO VERIFY INVERT OF EXISTING SEWER
- S2 STA 10+411, RT 18.2 m - STA 10+387, RT 22.6 m (BY OTHERS)  
200 x 23.1 m DI PIPE WITH 450 x 17.7 m STEEL SLEEVE  
PRC - DROP SMH WITH COVER AT STA 10+411, RT 18.2 m  
RIM EL. = 76.00 +/-  
INV. AT DROP (N) = 74.727  
INV. IN (N) = 72.898  
INV. OUT = 72.867
- S3 STA 10+496, RT 4.2 m - STA 10+411, RT 18.2 m  
200 x 86.1 m PVC SDR26 WITH 450 x 6.1 m STEEL SLEEVE  
PRC - SMH WITH COVER AT STA 10+496, RT 4.2 m  
RIM EL. = 89.906  
INV. IN (N) = 86.056  
INV. OUT (S) = 86.025
- S4 STA 10+534, RT 4.2 m - STA 10+496, RT 4.2 m  
200 x 37.6 m PVC SDR26 WITH 450 x 6.1 m STEEL SLEEVE  
PRC - SMH WITH COVER AT STA 10+534, RT 4.2 m  
RIM EL. = 92.946  
INV. IN (N) = 88.834  
INV. OUT (S) = 88.803
- S5 STA 10+553.9, RT 4.2 m - STA 10+534, RT 4.2 m  
200 x 19.1 m PVC SDR35  
PRC - SMH WITH COVER AT STA 10+553.9, RT 4.2 m  
RIM EL. = 94.384  
INV. IN (N) = 89.803  
INV. IN (W) = 89.803  
INV. OUT (S) = 89.772
- S6 STA 10+572, RT 4.2 m - STA 10+553.9, RT 4.2 m  
200 x 17.2 m PVC SDR35  
PRC - SMH WITH COVER AT STA 10+572, RT 4.2 m  
RIM EL. = 95.297  
INV. IN (N) = 90.588  
INV. OUT (S) = 90.557
- S7 STA 10+567.2, LT 8.0 m - STA 10+553.9, RT 4.2 m  
150 x 16.7 m PVC SDR35  
PRC-SMH WITH COVER AT STA 10+567.2, LT 8.0 m  
RIM EL. = 94.890  
INV. IN (W) = 90.603  
INV. OUT (E) = 90.572
- S8 STA 10+608, LT 6.0 m - STA 10+572, RT 4.2 m  
200 x 36.5 m PVC SDR35  
INV. OUT (S) = 90.953  
REMOVE AND RESET FRAME AND COVER OF EXISTING SEWER MANHOLE  
AT STA. 10+608, LT 6.0 m  
RIM EL. = 96.322  
REMOVE AND RESET BRICK CHANNEL TO PROPOSED OUTLET PIPE LOCATION.

**GENERAL SEWER NOTES**

1. THE STEEL SLEEVE UNDER THE RAILROAD TRACKS SHALL BE JACKED. OPEN CUTS ARE PROHIBITED.
2. PRIOR TO THE INSTALLATION OF THE STEEL SLEEVES, THE CONTRACTOR SHALL VERIFY THE LOCATION OF THE EXISTING VERTICAL FACES OF QUARRY.
3. THE CONTRACTOR SHALL VERIFY THE LOCATION AND INVERT ELEVATION OF THE EXISTING SEWER LATERAL FROM SALMON HALL AND IS RESPONSIBLE FOR FURNISHING ALL EQUIPMENT, MATERIALS AND LABOR NECESSARY TO MAKE A SECURE WATER-TIGHT CONNECTION TO THE EXISTING SEWER LATERAL. ANY CONFLICTS BETWEEN THE ACTUAL LOCATION AND DESIGN SHALL BE REPORTED TO THE RESIDENT ENGINEER FOR RESOLUTION.
4. THE CONTRACTOR SHALL CORE THROUGH THE EXISTING SEWER MANHOLE WALL SECURING THE PROPOSED OUTLET PIPE TO THE MANHOLE USING NON-SHRINK GROUT. AFTER COMPLETING WORK ON THE EXISTING SEWER MANHOLE THE CONTRACTOR SHALL PLUG AND ABANDON THE EXISTING OUTLET PIPE USING BRICK AND MORTAR.

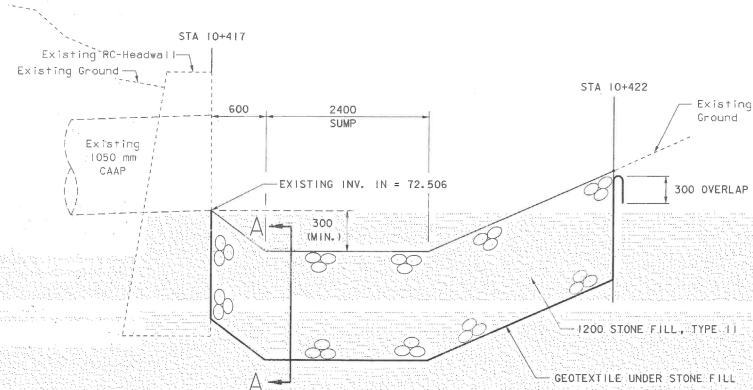

**SWALE DETAIL "B"**

NOT TO SCALE  
STA 10+417, RT - STA 10+422, RT  
NOTE: CONTRACTOR SHALL ENSURE THAT PLACEMENT OF STONE FILL WILL NOT UNDERMINE EXISTING HEADWALL.

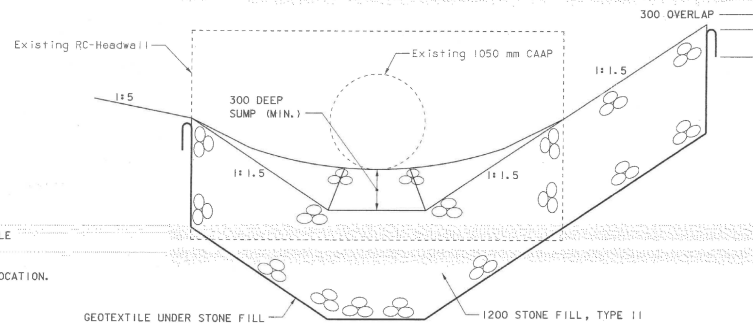

**SECTION A-A**

NOT TO SCALE

DATUM  
VERTICAL NAVD 88  
HORIZONTAL NAD 83 (92)

VANASSE HANGEN BRUSTLIN, INC.

**STATE OF VERMONT  
AGENCY OF TRANSPORTATION**

Town Of COLCHESTER-SOUTH BURLINGTON	Bridge No. 6
Highway No. TH 4/3	Log Sta. Surv. Sta.
TH 4/3 OVER WINOOSKI RIVER & N.E. C.R.	

**DRAINAGE & SEWER NOTES/DETAILS (2 OF 2)**

Designed By S. W. BEKIER	Drawn By C. S. MERCER
Checked By D. M. PECK	Bridge Design Supervisor S. M. GUNN
Date 6/03	Date 6/03
PROJECT COLCHESTER-SOUTH BURLINGTON	PROJECT NO. BRM 5600 (6) S C/2
I.G.C. Info.	
Bridge Sheet No. ZD139DR2	R.O.W. SHEET 6 OF 21