

BRIDGE TYPICAL SECTION
SCALE: 3/8" = 1'-0"

*(SECOND LIFT: 1/4" TYPE III
FIRST LIFT: 1/4" TYPE IV)

NOTES

1. COFFERDAM LIMITS TO BE DETERMINED BY THE CONTRACTOR.
2. FOR PURPOSES OF ESTIMATING EARTHWORK QUANTITIES, THE LIMITS OF COFFERDAM HAVE BEEN ASSUMED TO BE 2'-0" OUTSIDE THE PERIMETER OF THE FOOTING.
3. ONE FOOT UNDERCUT AS DETERMINED NECESSARY BY THE RESIDENT ENGINEER.
4. IF A COFFERDAM IS CONSTRUCTED WHICH IS MORE THAN THE INDICATED MINIMUM DISTANCE OUTSIDE THE FOOTING LIMITS, PAYMENT FOR ALL UNCLASSIFIED CHANNEL EXCAVATION INCLUDING THAT PORTION WHICH IS INSIDE THE COFFERDAM BUT OUTSIDE THE MINIMUM COFFERDAM LIMITS SHOWN WILL BE MADE AT THE CONTRACT UNIT PRICE FOR UNCLASSIFIED CHANNEL EXCAVATION.

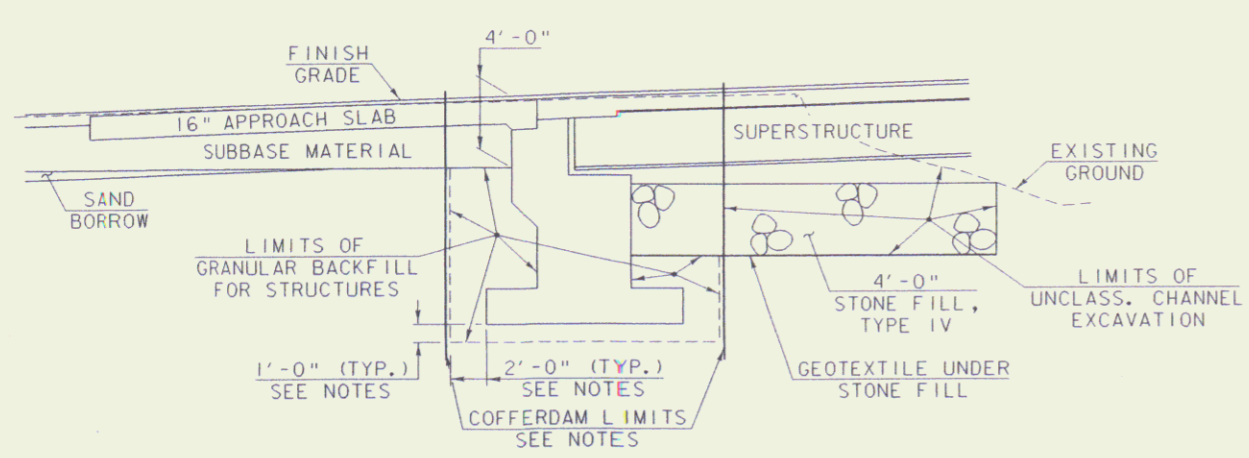

TYPICAL ABUTMENT SECTION
NOT TO SCALE

EXISTING STRUCTURE

1. STRUCTURE TYPE	THREE SPAN STEEL BEAM BRIDGE	OVERALL LENGTH	252 FT	INVENTORY RATING	NA
2. SPAN LENGTH(S) CENTER TO CENTER OF BEARINGS	THREE SPANS: 81'-6" - 81'-11" - 81'-6"				
3. CLEAR SPAN LENGTH(S) NORMAL TO STREAM	THREE SPANS @ 55 FT = 165 FT				
4. WATERWAY AREA OF FULL OPENING (NORMAL TO STREAM)	2000 SQ FT	VERTICAL CLEARANCE ABOVE STREAMBED	11 FT		
5. WATER SURFACE ELEVATION @ 0.2:33	1132.4	WATER SURFACE ELEVATION @ 0.50	1134.5		
6. WATER SURFACE ELEVATION AT FLOOD OF RECORD	NA	YEAR	NA	ESTIMATED DISCHARGE	NA
7. DOES ALL WATER PASS THROUGH EXISTING STRUCTURE? YES IF NOT, AT WHAT FREQUENCY AND ELEVATION DOES RELIEF OCCUR?	N/A				
8. TYPE OF SUBSTRUCTURE FOUNDATION MATERIAL	N/A				
9. DISPOSITION OF STRUCTURE	REHABILITATE				

NEW STRUCTURE

1. STRUCTURE TYPE	THREE SPAN CONTINUOUS PLATE GIRDER BRIDGE	OVERALL LENGTH	279.07 FT		
2. SPAN LENGTH(S) CENTER TO CENTER OF BEARINGS	SPAN ONE: 94'-0" SPAN TWO: 84'-0" SPAN THREE: 94'-0"				
3. VERTICAL CLEARANCE ABOVE STREAMBED OR ROAD UNDER	11 FT				
4. CLEAR SPAN LENGTH(S) NORMAL TO STREAM	SPAN ONE: 66'-6" SPAN TWO: 59'-5" SPAN THREE: 66'-6"				
5. WATERWAY AREA OF FULL OPENING (NORMAL TO STREAM)	2150 SQ FT				
6. ARE PROVISIONS TO BE MADE FOR PUBLIC UTILITIES?	YES				

HYDRAULIC DATA:

1. Q	2400 CFS	WATER ELEVATION	1132.4	VELOCITY	10.4 FPS
0.10	4000 CFS	WATER ELEVATION	1133.7	VELOCITY	10.6 FPS
0.25	5000 CFS	WATER ELEVATION	1134.1	VELOCITY	11.4 FPS
0.50	6000 CFS	WATER ELEVATION	1134.5	VELOCITY	12.1 FPS
0.100	7000 CFS	WATER ELEVATION	1134.9	VELOCITY	12.7 FPS
2. DRAINAGE AREA	37.7 SQ MI	CHARACTER OF TERRAIN	HILLY TO MOUNTAINOUS, MOSTLY FORESTED		
3. ARE THERE OBJECTIONS TO A PIER IN THE STREAM?	NO				
4. DOES STREAM REACH ITS MAXIMUM HIGH WATER ELEVATION RAPIDLY?	YES	IS ORDINARY RISE RAPID?	YES		
5. NATURE OF NATURAL STREAMBED	WELL ARMORED WITH MEDIUM TO LARGE COBBLES AND BOULDERS				
6. ESTIMATED SCOUR DEPTH	1 FT	COMMENT ON: DRIFT	MODERATE ICE SLIGHT		
7. WILL ALL WATER PASS THROUGH NEW STRUCTURE? YES IF NOT, WHAT FREQUENCY AND ELEVATION WILL RELIEF OCCUR?	N/A				
8. ADDITIONAL WATERWAY AREA PROVIDED BY RELIEF	N/A				
9. ALLOWABLE WATER SURFACE ELEVATION	1141.0	LIMITED BY	BOTTOM OF LOW BEAM ELEVATION		
10. IS DESIGN STAGE AFFECTED BY UPSTREAM OR DOWNSTREAM CONDITIONS?	NO IF YES, DESCRIBE				
11. ORDINARY LOW WATER	40 CFS	DEPTH	0.5 FT	ORDINARY HIGH WATER	1150 CFS
12. AVERAGE DAILY FLOW	80 CFS	STREAMBANK OR CHANNEL PROTECTION REQUIRED	STONE FILL, TYPE IV		
13. DISTANCE TO EXISTING UPSTREAM STRUCTURE	NA	SPAN	NA	WATERWAY AREA OF FULL OPENING	NA
14. DISTANCE TO EXISTING DOWNSTREAM STRUCTURE	1.7 MI	SPAN	209 FT	WATERWAY AREA OF FULL OPENING	NA

ALLOWABLE STRESSES:

1. DESIGN LIVE LOAD AASHTO	HS-20-44				
2. ALLOWABLE LOAD FOR SPREAD FOOTINGS ON SOIL	NA	TYPE	NA	ON LEDGE	NA
3. ALLOWABLE LOAD FOR PILING	N/A	TYPE	N/A	ESTIMATED LENGTH	N/A
4. ALLOWABLE STRESS FOR STRUCTURAL STEEL AASHTO	M270 G50W	TENSION	27000 PSI		
5. ALLOWABLE STRESS FOR REINFORCING STEEL GRADE 60 TENSION	24000 PSI	COMPRESSION	20000 PSI		
6. ALLOWABLE STRESS FOR CONCRETE CLASS A	f _c 4000 PSI	f _c	1600 PSI		
	CLASS B	f _c 3500 PSI	f _c	1400 PSI	
	SILICA-FUME	f _c 5000 PSI	f _c	2000 PSI	

TRAFFIC MAINTENANCE:

1. IS TRAFFIC TO BE MAINTAINED?	YES	IF YES, ON EXISTING STRUCTURE	NO	OR ON TEMPORARY BRIDGE	YES
2. TEMPORARY BRIDGE REQUIREMENTS: ONE OR TWO WAY	TWO WAY		TRAFFIC CONTROL SIGNALS REQUIRED	NA	
MINIMUM CLEAR SPAN	100 FT	MINIMUM CLEAR HEIGHT	8 FT	MINIMUM WATERWAY AREA	800 SQ FT
ARE SIDEWALKS REQUIRED?	NO IF SO, ON WHAT SIDE? N/A				

NOTE: NA = INFORMATION NOT AVAILABLE N/A = INFORMATION NOT APPLICABLE

MINIMUM TEMPORARY BRIDGE REQUIREMENTS

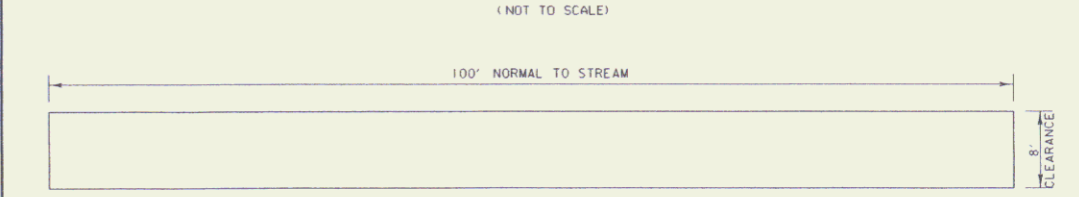

NOTE: ONE PIER IN THE CHANNEL IS ACCEPTABLE. PIER MUST BE AS NARROW AS POSSIBLE AND PROPERLY ALIGNED WITH THE CHANNEL.

MAR 27 2008

LOAD RATING (TONS)

STRESS LEVELS	H	HS	352	TRUCK	6 AXLE	3A, STR.	4A, STR.	5A, SEMI
INVENTORY								
0.55 F _y								
0.67 F _y								
OPERATING								
0.75 F _y								

STATE OF VERMONT AGENCY OF TRANSPORTATION

Town of **WOODFORD** Bridge No. **11**
Highway No. **VT. 9** Log Sta.
Surv. Sta.

VT. 9 OVER ROARING BRANCH OF WALLOMSAC RIVER

PRELIMINARY INFORMATION

Designed By **T. SCHMELZENBACH** Drawn By **G. ROY**
Checked By **T. SCHMELZENBACH** Date **4/94** Bridge Design Supervisor
J. H. WEAVER Date **4/94**
PROJECT **WOODFORD** PROJECT NO. **BHF 010-M-291**
I.G.C. info. **/proj/846039/ra039pl.dgn** ra039pl
R. O. W. SHEET 6 OF 11 SHEETS

PLOTTED 6 JUN 1997