

TYPICAL CHANNEL SECTION
(NOT TO SCALE)

* GRUBBING MATERIAL SHALL NOT BE PLACED ON THE STONE FILL IN THE AREA UNDER THE BRIDGE. WHENEVER CHANNEL SLOPE INTERSECTS ROADWAY SUBBASE, GRUBBING MATERIAL SHALL BEGIN AT THE BOTTOM OF SUBBASE.

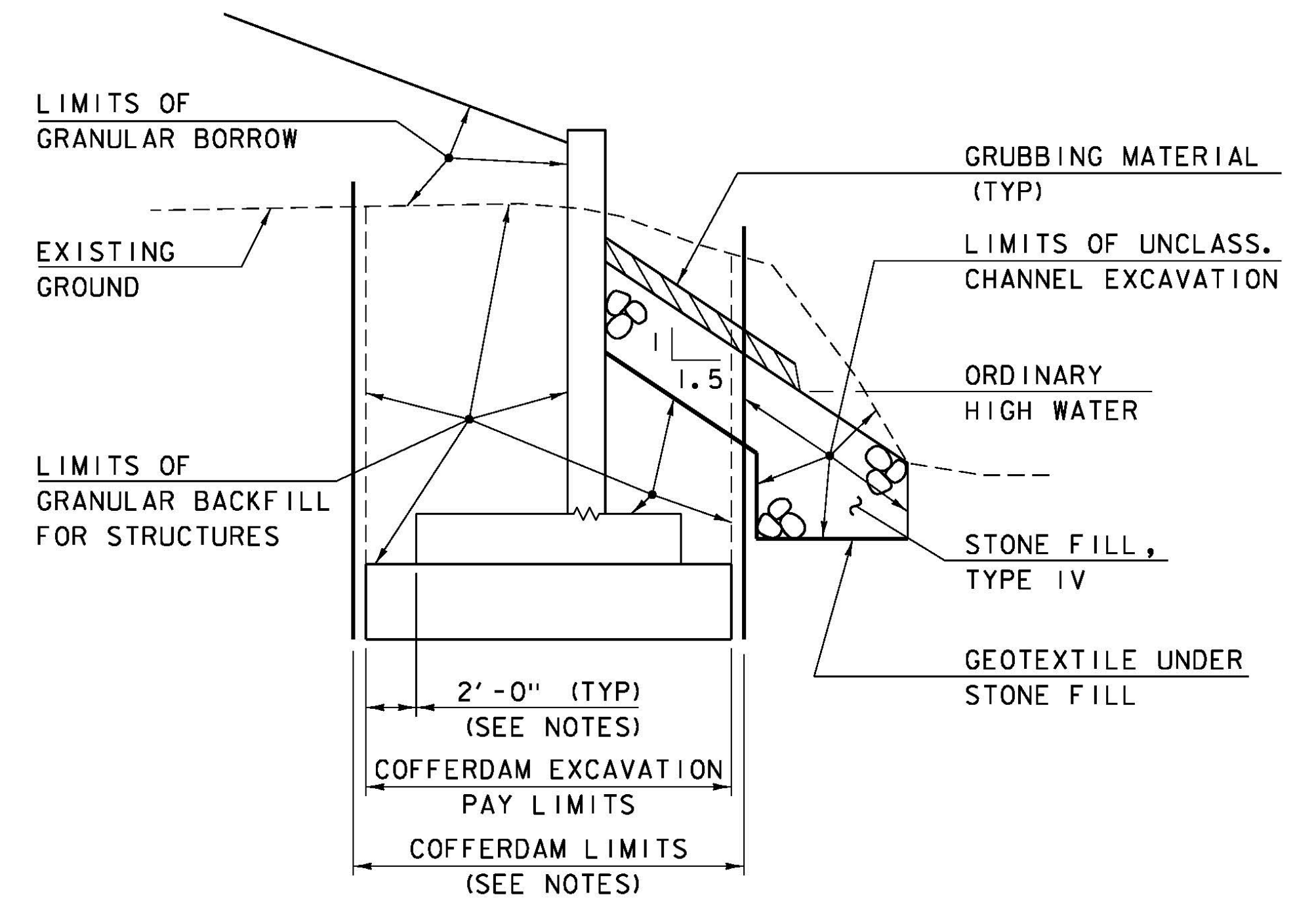

TYPICAL WINGWALL EARTHWORK SECTION
(NOT TO SCALE)

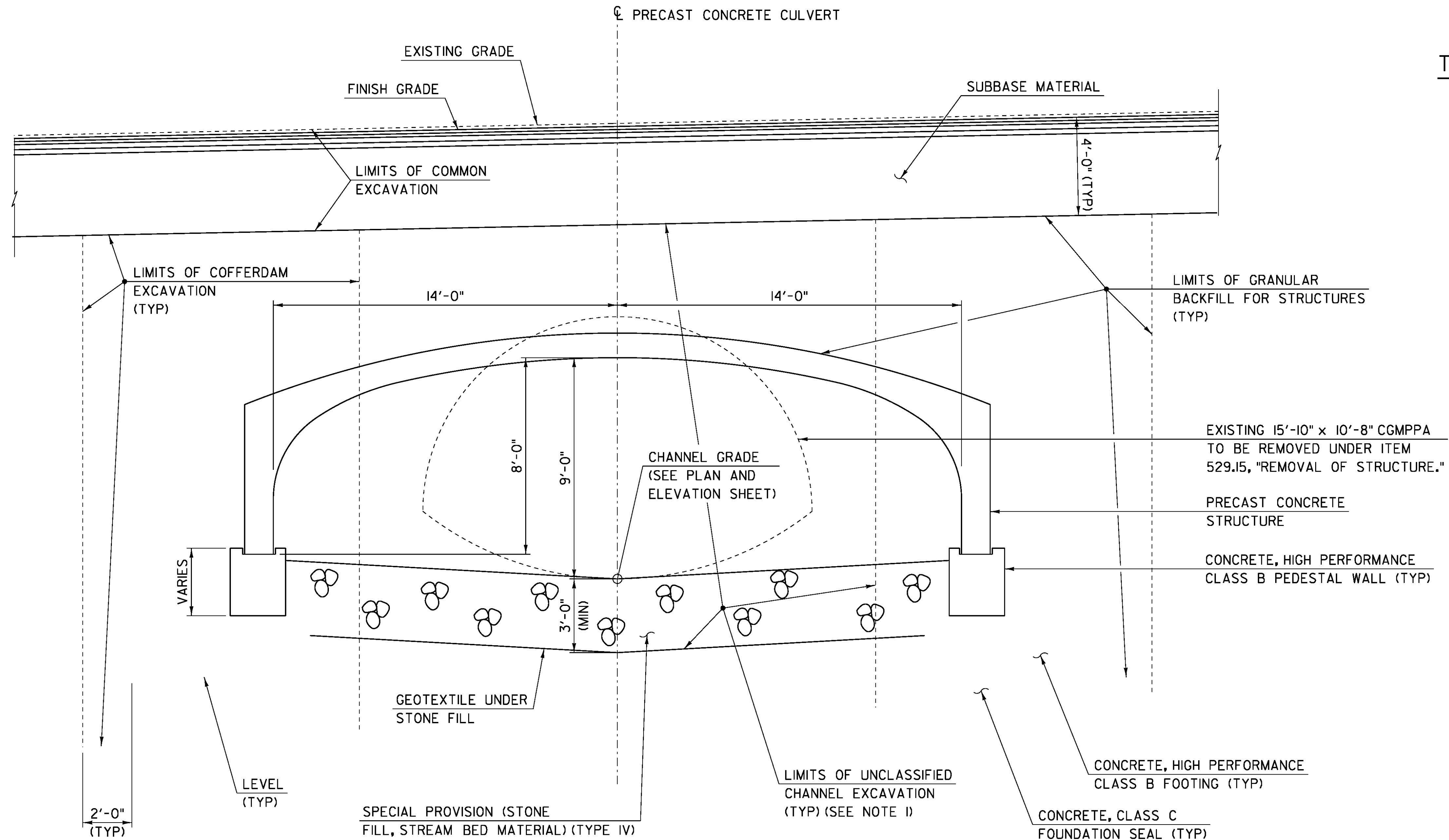

PRECAST CONCRETE CULVERT AND EARTHWORK TYPICAL SECTION

(NORMAL TO CHANNEL ALIGNMENT)
SCALE: 3/8" = 1'-0"

NOTES:

1. LIMITS EXCLUDE EXISTING CGMPA CULVERT. REMOVAL OF LEDGE NOT REQUIRED FOR PLACEMENT OF STONE FILL.
2. THE CONTRACTOR IS MADE AWARE OF THE POTENTIAL TO ENCOUNTER EXISTING SUBSTRUCTURE REMNANTS. REMOVAL OF ANY EXISTING SUBSTRUCTURE WILL BE PAID UNDER ITEM 208.35, "COFFERDAM EXCAVATION, ROCK."
3. COFFERDAM DIMENSIONS TO BE DETERMINED BY THE CONTRACTOR.
4. THE PAY LIMITS OF EITHER "COFFERDAM EXCAVATION, EARTH" OR "COFFERDAM EXCAVATION, ROCK" SHALL BE 2'-0" OUTSIDE THE PERIMETER OF THE FOOTING AND FROM BOTTOM OF EXCAVATION UP TO THE EXISTING GROUND OR BOTTOM OF SUBBASE, WHICHEVER IS LOWER.
5. IF A COFFERDAM IS CONSTRUCTED WHICH IS LARGER THAN THE INDICATED COFFERDAM EXCAVATION PAY LIMITS, PAYMENT FOR ALL UNCLASSIFIED CHANNEL EXCAVATION, INCLUDING THAT PORTION WHICH IS INSIDE THE COFFERDAM BUT OUTSIDE THE COFFERDAM PAY LIMITS, WILL BE MADE AT THE CONTRACT UNIT PRICE FOR UNCLASSIFIED CHANNEL EXCAVATION. NO MEASUREMENT AND PAYMENT WILL BE MADE FOR COFFERDAM EXCAVATION AND GRANULAR BACKFILL FOR STRUCTURES OUTSIDE THE PAY LIMITS DEFINED IN NOTE 4.

PROJECT NAME: DUXBURY	PLOT DATE: 05-MAY-2016
PROJECT NUMBER: BF 013-4(47)	DRAWN BY: TYLIN
FILE NAME: r16b001typ2.dgn	CHECKED BY: TYLIN
PROJECT LEADER: K. HIGGINS	SHEET 8 OF 19
DESIGNED BY: TYLIN	TYPICAL SECTIONS & DETAILS 2