

5 ONSITE CONCRETE SIDEWALK CROSS-SECTION  
N.T.S.

6 TYPICAL START / END CURB RETURN RADIUS  
N.T.S.

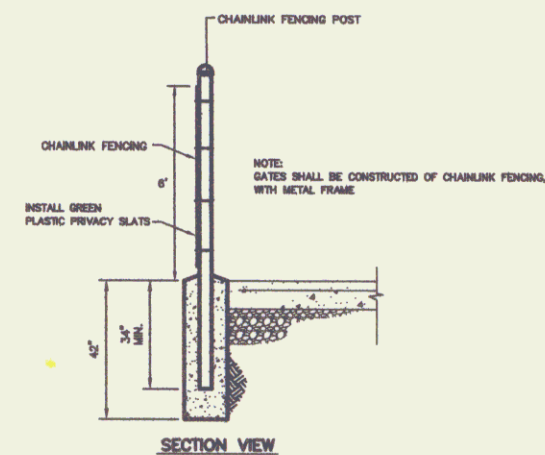

7 DUMPSTER ENCLOSURE DETAILS  
N.T.S.

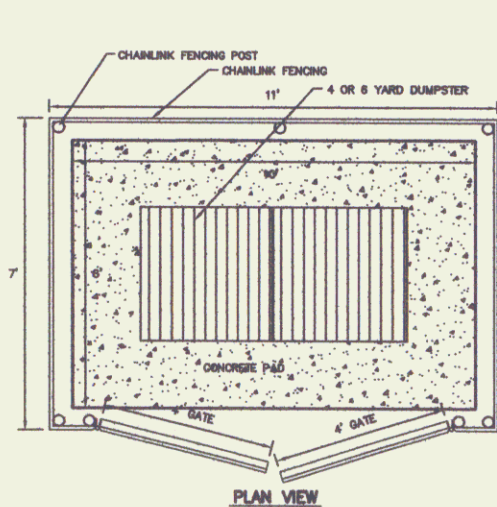
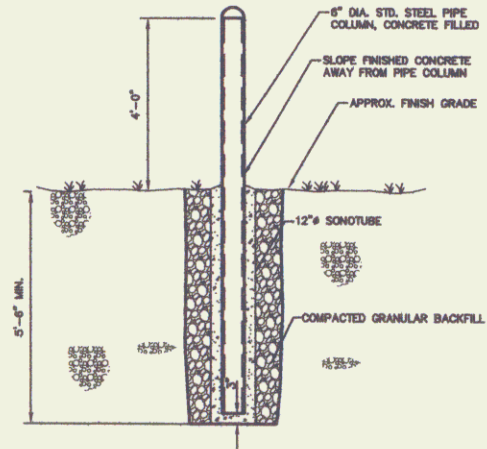

8 EXTERIOR BOLLARD  
N.T.S.

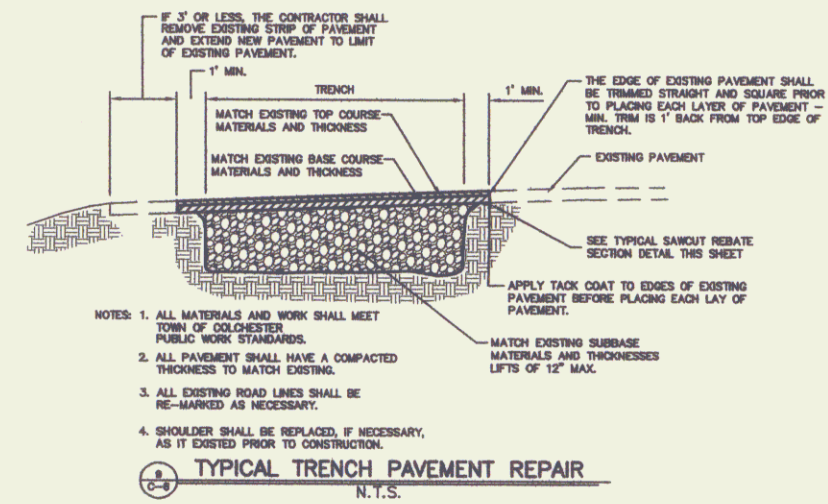

9 TYPICAL TRENCH PAVEMENT REPAIR  
N.T.S.

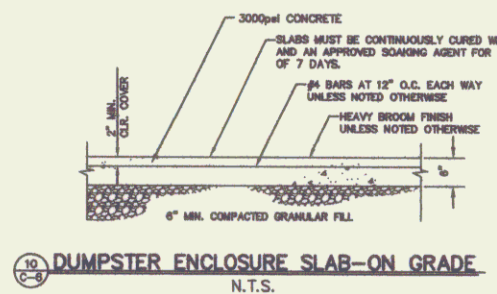

10 DUMPSTER ENCLOSURE SLAB-ON GRADE  
N.T.S.

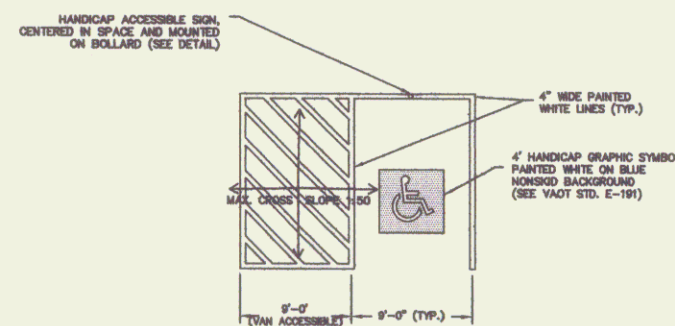

11 ACCESSIBLE SPACE PAVEMENT MARKING  
N.T.S.

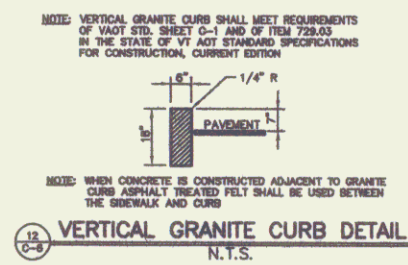

12 VERTICAL GRANITE CURB DETAIL  
N.T.S.

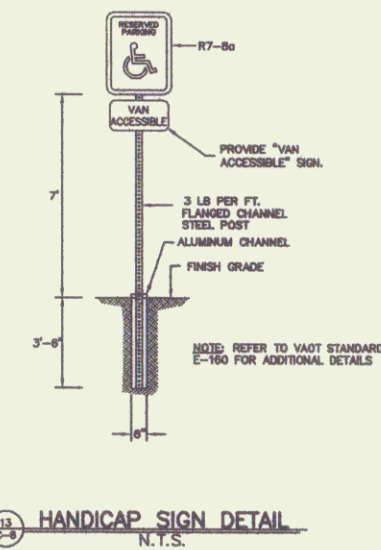

13 HANDICAP SIGN DETAIL  
N.T.S.

REVISION DATE & DESCRIPTION	BY
12/12/07 - REVISED	MEC
3/15/08 - TOWN REVISION	MEC

**Champlain Consulting ENGINEERS**  
 45 FIRM ROAD, P.O. BOX 453  
 COLCHESTER, VERMONT 05446  
 (802) 863-8000 • 864-1878 FAX  
CONFIDENTIAL © 2007 CHAMPLAIN CONSULTING ENGINEERS. ALL RIGHTS RESERVED.

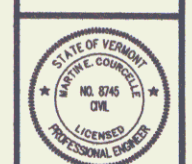

**CBAY CARWASH & 4 ROOSEVELT HIGHWAY U.S. ROUTES 2 & 7 SITE DETAILS**  
 COLCHESTER VERMONT

DRAWN	CCE
CHECKED	MEC
SCALE	N.T.S.
DATE	11/08/07
JOB NO.	27141
SHEET	6