

TYPICAL ABUTMENT SECTION
(NOT TO SCALE)

NOTES

1. COFFERDAM LIMITS TO BE DETERMINED BY THE CONTRACTOR.
2. THE PAY LIMITS OF "COFFERDAM EXCAVATION, EARTH" AND "COFFERDAM EXCAVATION, ROCK" SHALL BE 2'-0" OUTSIDE THE PERIMETER OF THE FOOTING, UP TO EXISTING GROUND OR BOTTOM OF SUBBASE, WHICHEVER IS LOWER.
3. ONE FOOT UNDERCUT AS DETERMINED NECESSARY BY THE RESIDENT ENGINEER.
4. IF A COFFERDAM IS CONSTRUCTED WHICH IS LARGER THAN THE INDICATED COFFERDAM EXCAVATION PAY LIMITS, PAYMENT FOR ALL UNCLASSIFIED CHANNEL EXCAVATION, INCLUDING THAT PORTION WHICH IS INSIDE THE COFFERDAM BUT OUTSIDE THE COFFERDAM EXCAVATION PAY LIMITS, WILL BE MADE AT THE CONTRACT UNIT PRICE FOR UNCLASSIFIED CHANNEL EXCAVATION.

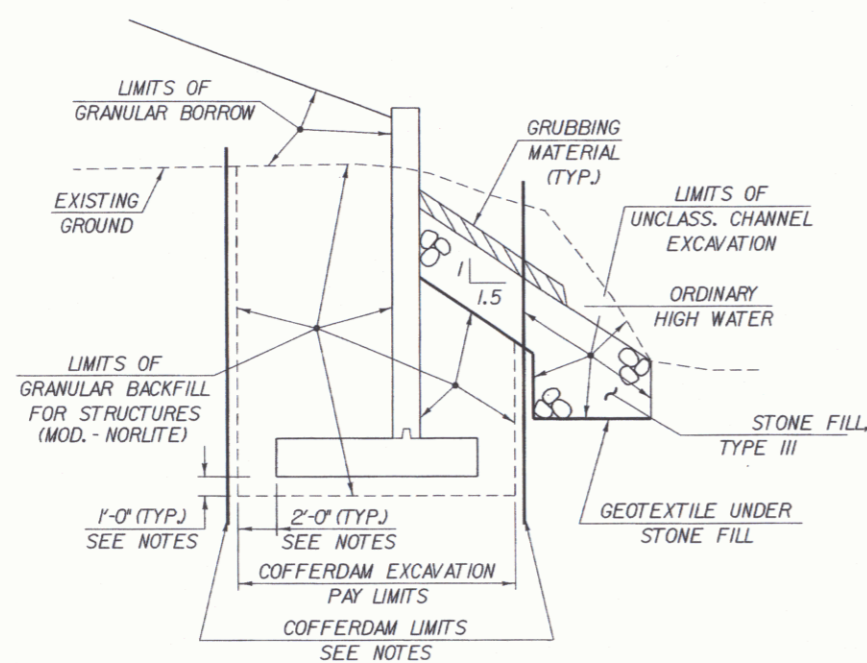

TYPICAL WINGWALL SECTION
(NOT TO SCALE)

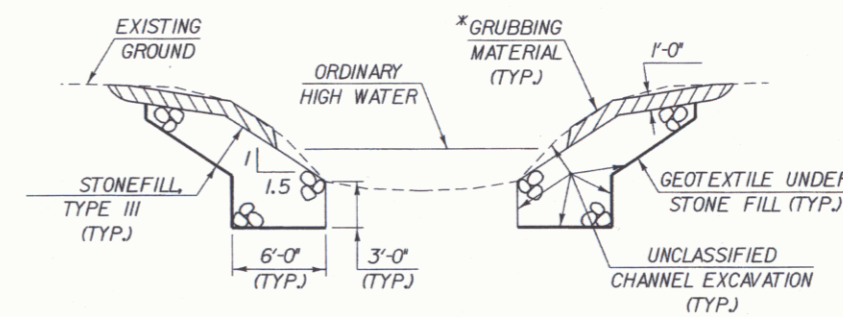

TYPICAL CHANNEL SECTION
(NOT TO SCALE)

*GRUBBING MATERIAL SHALL NOT BE PLACED ON THE STONE FILL IN THE AREA UNDER THE BRIDGE. WHENEVER CHANNEL SLOPE INTERSECTS ROADWAY SUBBASE, GRUBBING MATERIAL SHALL BEGIN AT THE BOTTOM OF SUBBASE.

APR 19 2010

TYPICAL SECTIONS (2)

PROJECT NAME:	Canaan	PLOT DATE:	03-AUG-2007
PROJECT NUMBER:	ER ST 0271(16)	DRAWN BY:	T. Husk
FILE NAME:	Structures\x04c098typ.dgn	CHECKED BY:	S. Scribner
PROJECT LEADER:	M. Evans-Mongeon	ROW SHEET:	3 OF 15 SHEETS
DESIGNED BY:	S. Scribner		