

GENERAL NOTES:

1. FOR DESCRIPTION AND SPECIFICATION OF PART IDENTIFIED - "ARTBA" SEE LATEST REPORT PREPARED AND APPROVED BY THE AASHTO-AGC-ARTBA JOINT COOPERATIVE COMMITTEE. "A GUIDE TO STANDARDIZED HIGHWAY BARRIER RAIL HARDWARE".
2. ALL ANGLES, CHANNELS, PLATES, DIAPHRAGM PLATES AND RECTANGULAR STRUCTURAL TUBING SHALL CONFORM TO THE REQUIREMENTS OF THE VAOT STANDARD SPECIFICATIONS, SUBSECTION 714.11. WELDING SHALL MEET THE CURRENT REQUIREMENTS OF THE VAOT STANDARD SPECIFICATIONS, SUBSECTION 506.10. ALL STRUCTURAL STEEL SHALL BE GALVANIZED IN ACCORDANCE WITH VAOT STANDARD SPECIFICATIONS, SECTION 714 - STRUCTURAL STEEL.
3. SHORT WOODEN BREAKAWAY POSTS SHALL BE MADE OF S4S TIMBER WITH A BENDING STRESS GRADE OF 1200 PSI MINIMUM AND SHALL BE GRADE MARKED OR CERTIFIED BY A RECOGNIZED ASSOCIATION OR AGENCY WHICH IS CERTIFIED BY THE BOARD OF REVIEW, AMERICAN LUMBER STANDARDS COMMITTEE, TO GRADE THE SPECIES. THE POSTS SHALL RECEIVE A PRESERVATIVE TREATMENT, AFTER ANY TRIMMING OR DRILLING, IN ACCORDANCE WITH VAOT STANDARD SPECIFICATIONS, SUBSECTION 728.01.
4. THE POST OFFSET DIMENSIONS ARE GIVEN TO THE FACE OF GUARDRAIL. THE POSTS ARE TO BE SET RADIAL TO THE RAILING AT EACH POST LOCATION.
5. NOTE: THE AREA OUTSIDE AND DOWNSTREAM OF THE FIRST 12 1/2' (BREAKAWAY NOSE SECTION) OF THE MELT SHOULD BE FREE OF OBSTACLES AND GRADED IN SUCH A WAY AS TO ALLOW A VEHICLE TO BREAK THROUGH THE BREAKAWAY NOSE SECTION AND COME TO A SAFE STOP.

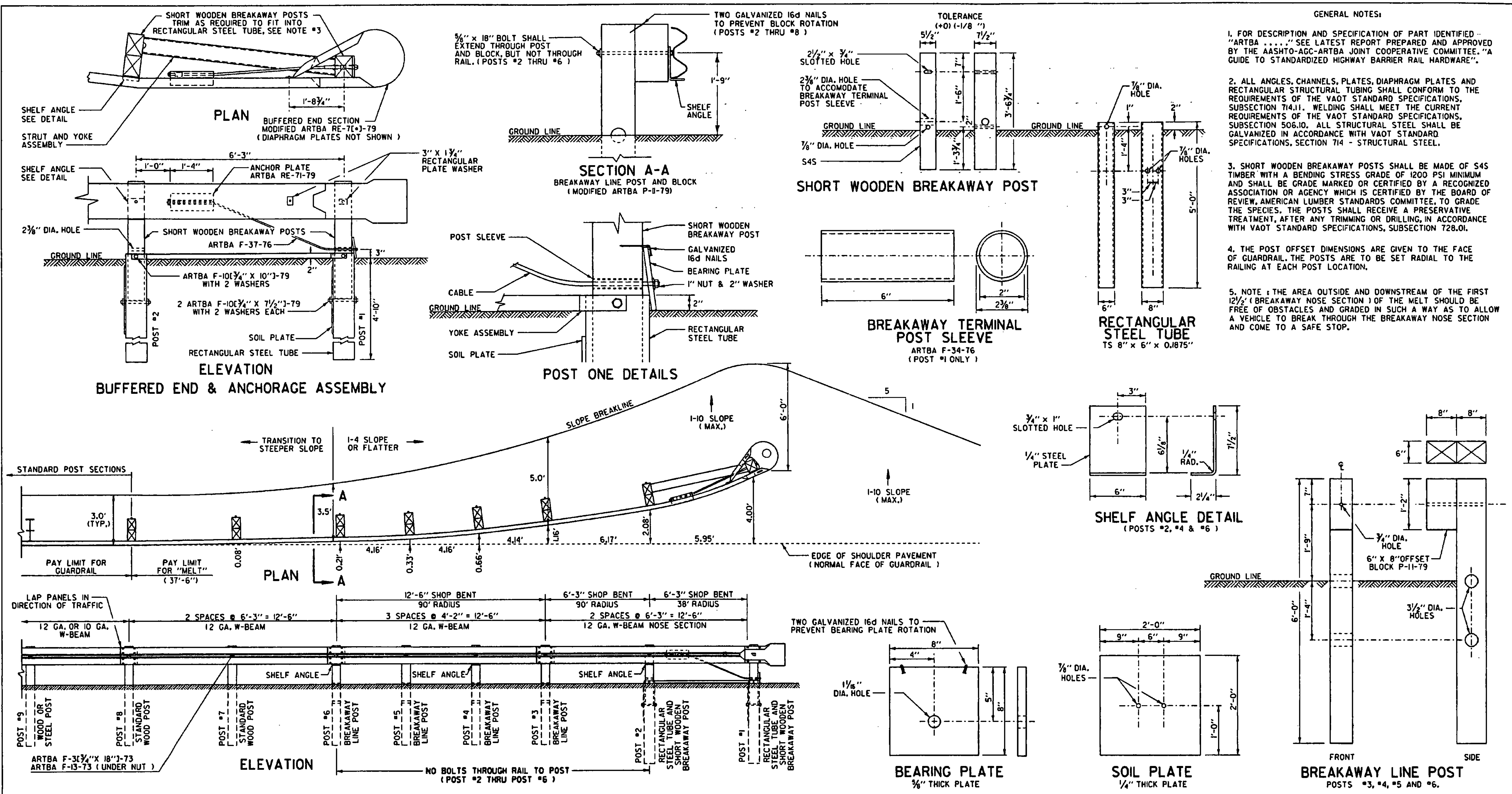

REVISIONS AND CORRECTIONS
 JUNE 30, 1995 ORIGINAL APPROVAL
 JANUARY 18, 1996 CHANGED DIAMETER
 AND LENGTH OF BOLT (SECTION A-A)

APPROVED
 APPROVED FOR THIS PROJECT
 AND/OR DESIGN IMPLEMENTATION
 FIVE FINAL APPROVAL PENDING.
John E. ...
 DIRECTOR OF ENGINEERING
Michael ...
 DESIGN ENGINEER

**MODIFIED ECCENTRIC LOADER TERMINAL
 WITH WOOD POSTS
 (MELT)**

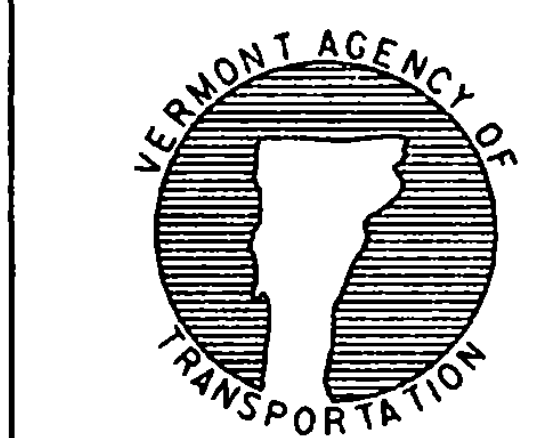

**STANDARD
 G-17 a**