

TYPICAL PAVEMENT MARKINGS

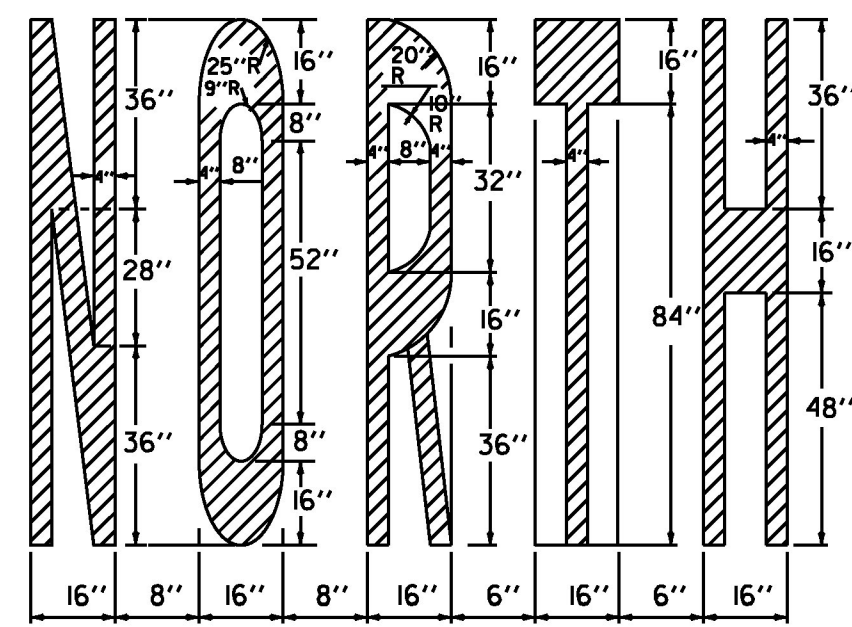

ADJUST TO AVAILABLE PAVEMENT WIDTH

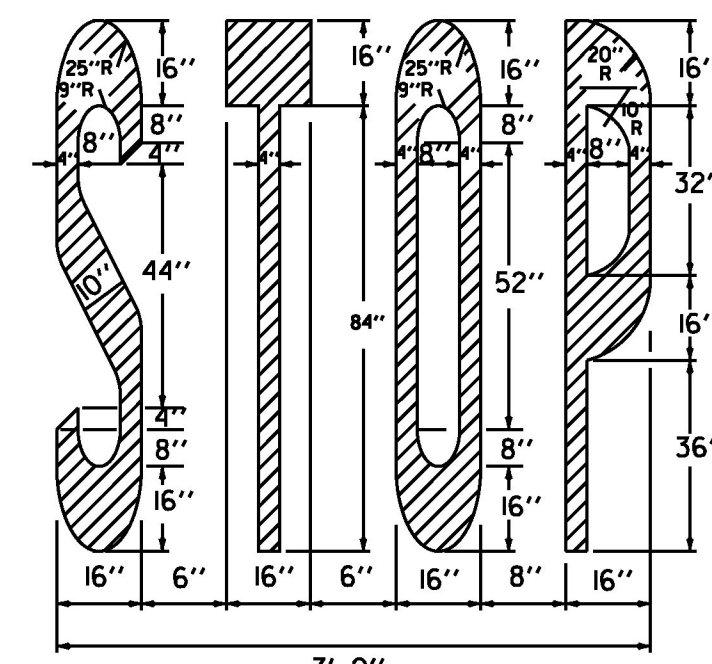

(* 6") - ADJUST TO AVAILABLE PAVEMENT WIDTH

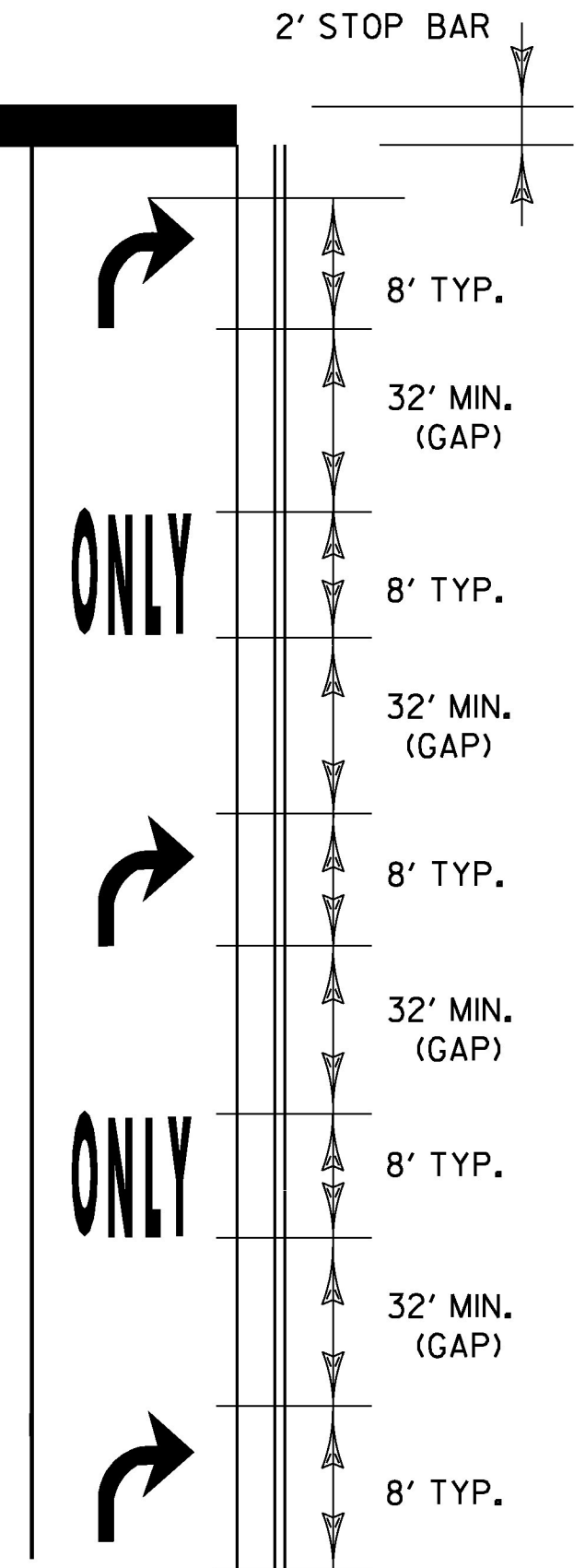
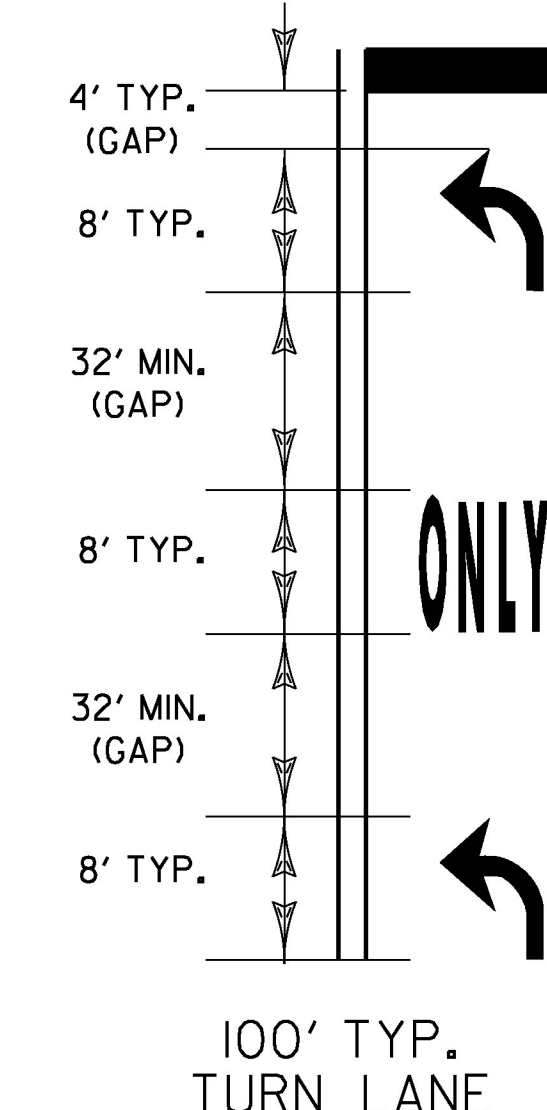
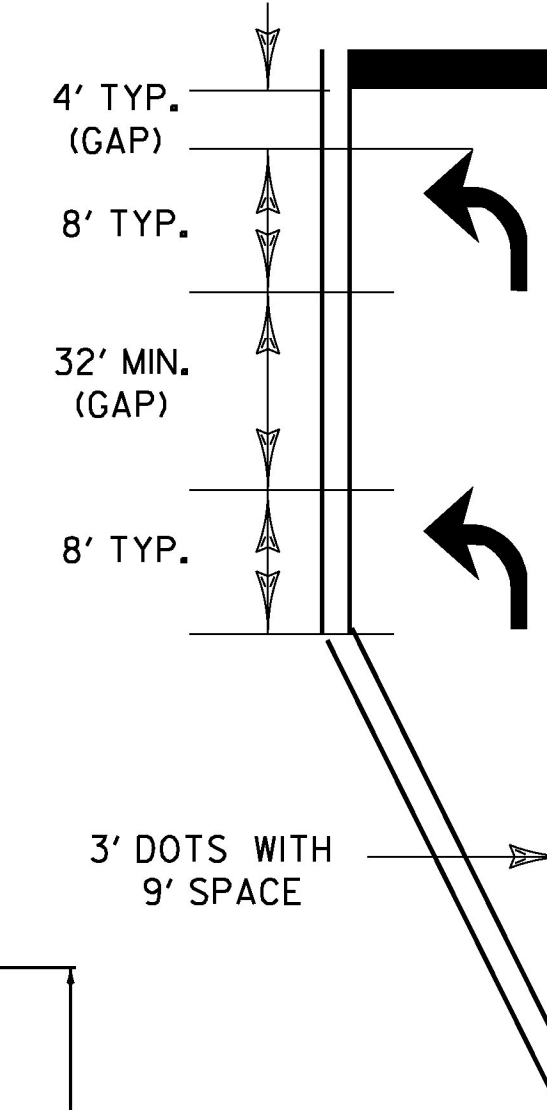
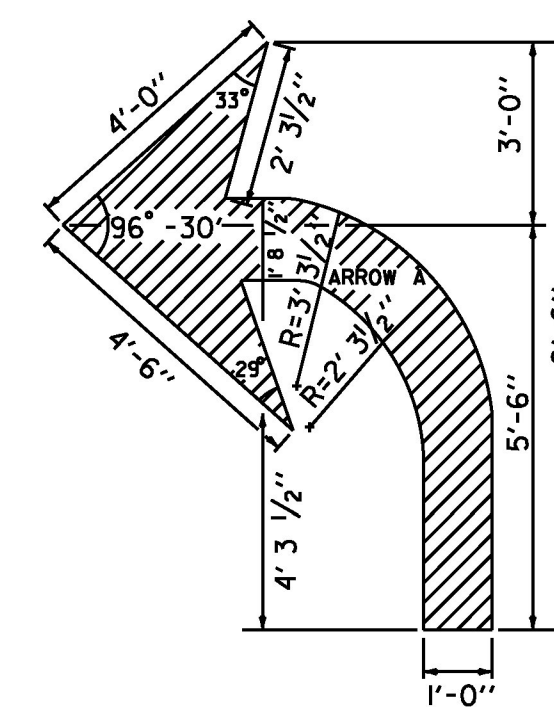
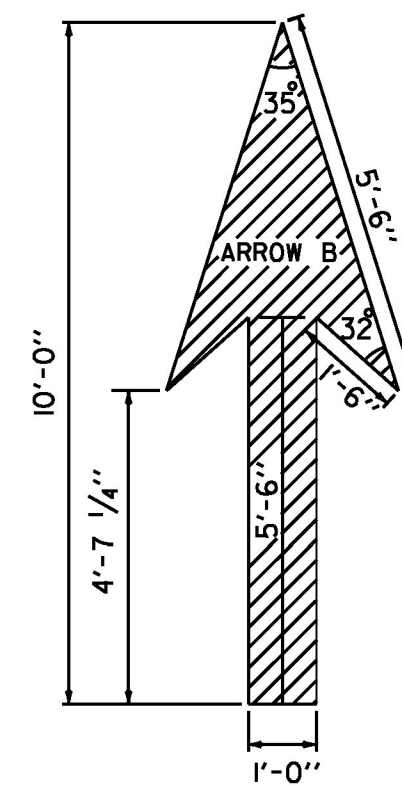
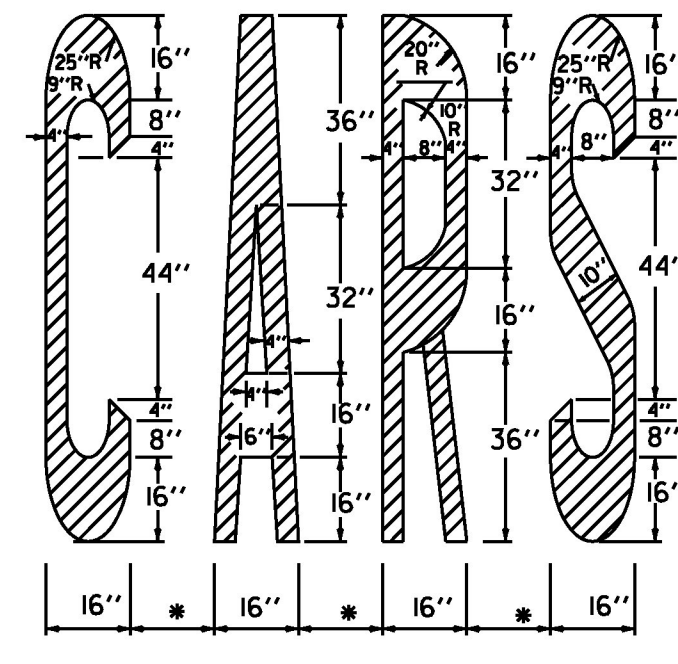

200' TYP. TURN LANE

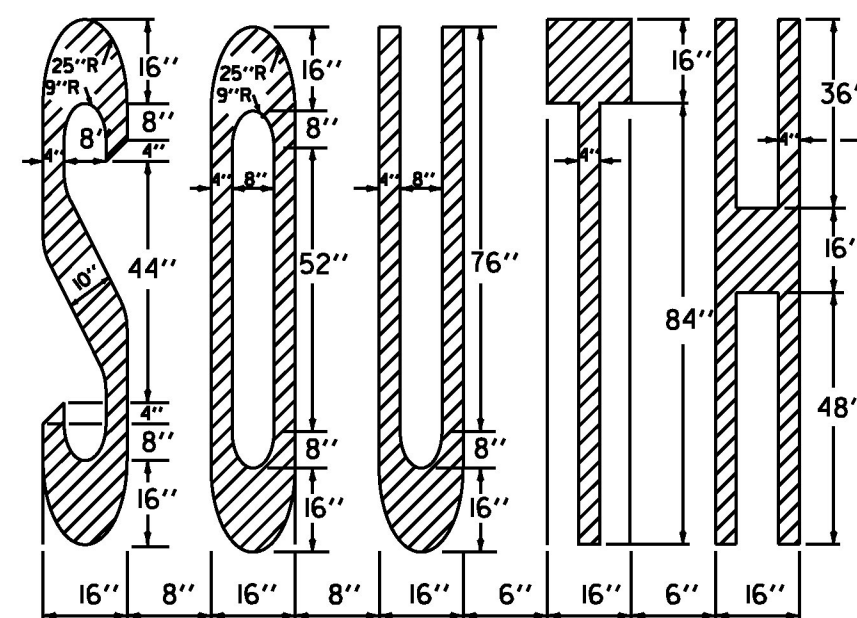

ADJUST TO AVAILABLE PAVEMENT WIDTH

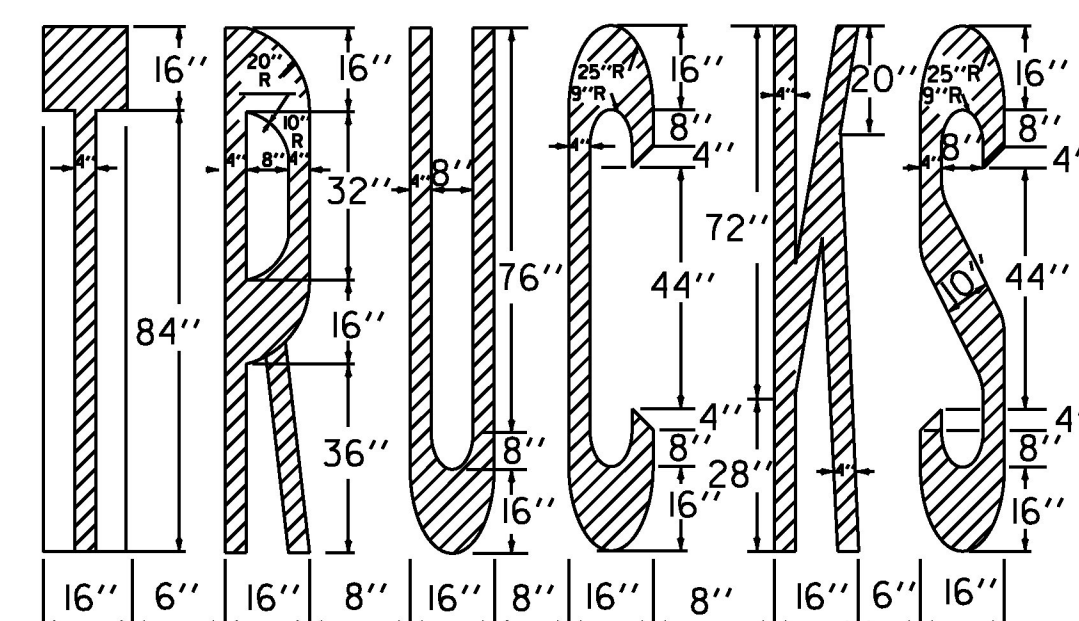
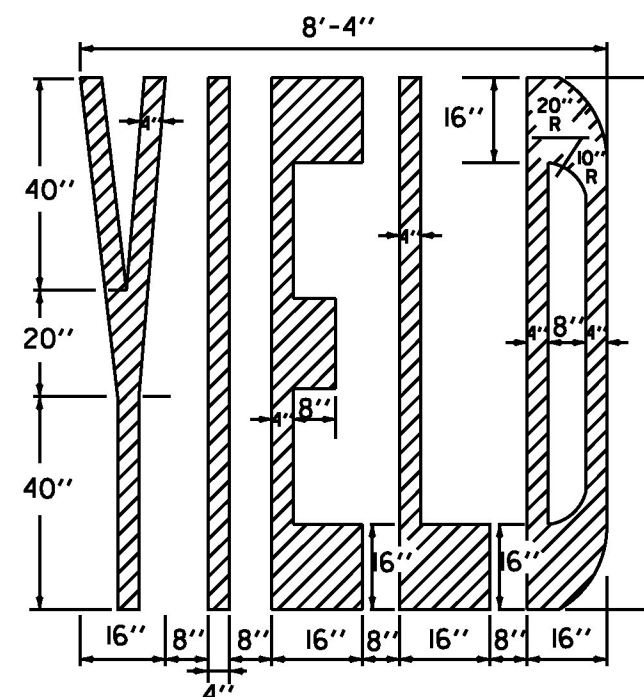

ADJUST TO AVAILABLE PAVEMENT WIDTH

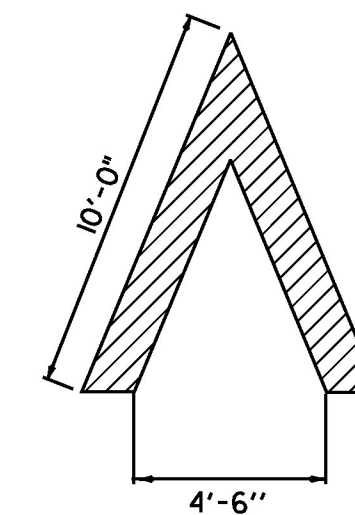

ARROW HEAD DETAIL

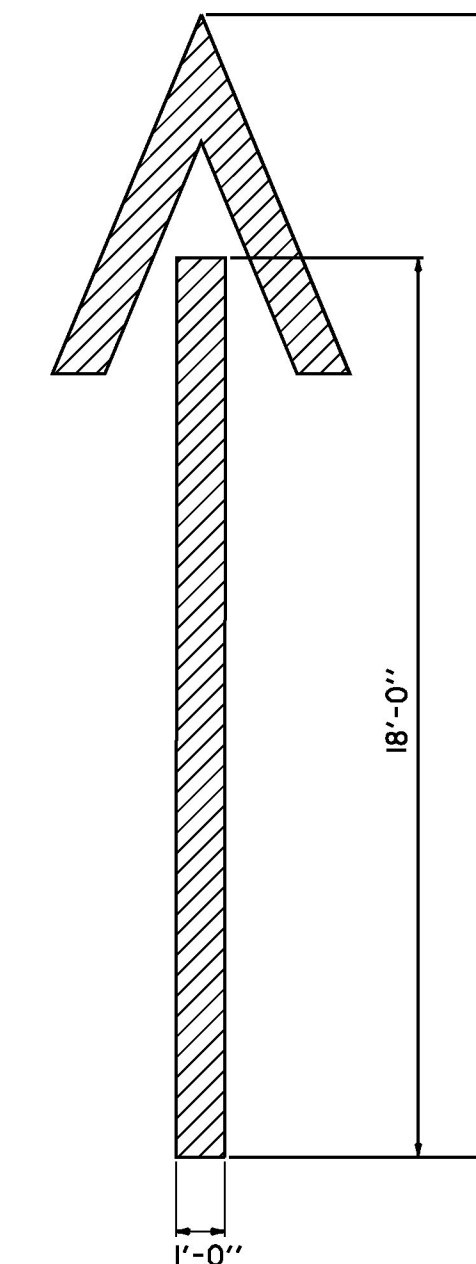

WRONG WAY ARROW

50'-100' TYP. TURN LANE

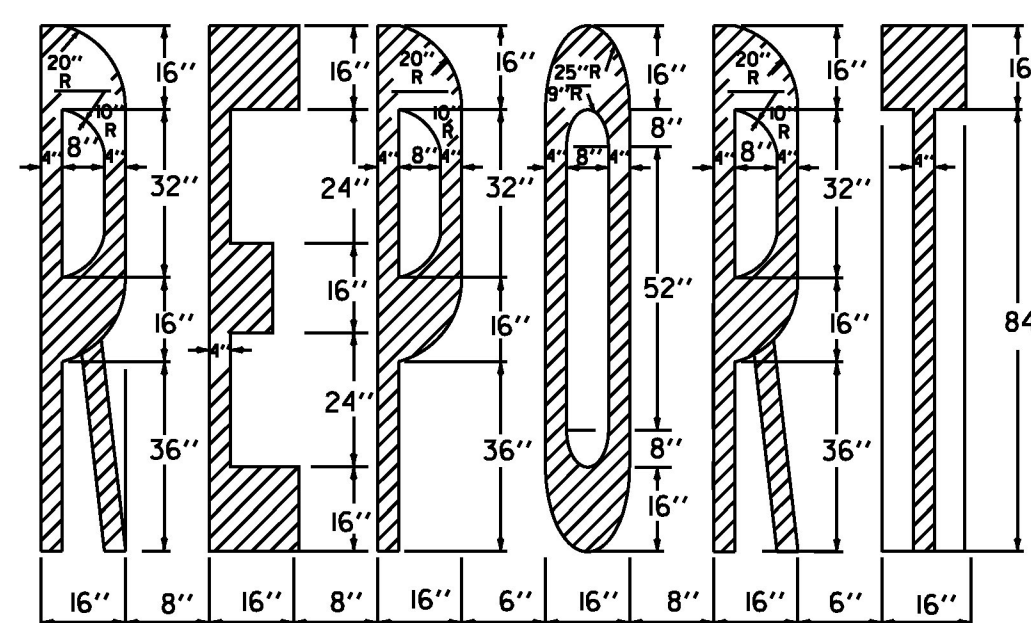

ADJUST TO AVAILABLE PAVEMENT WIDTH

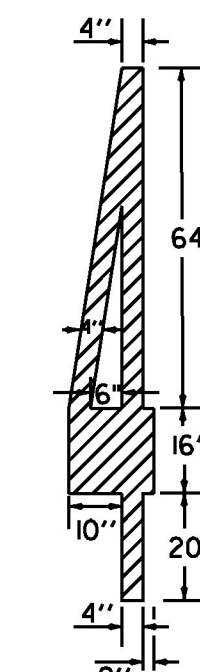
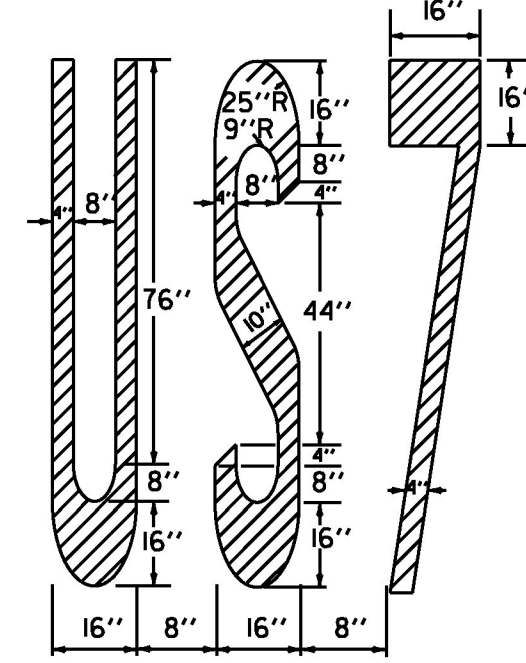
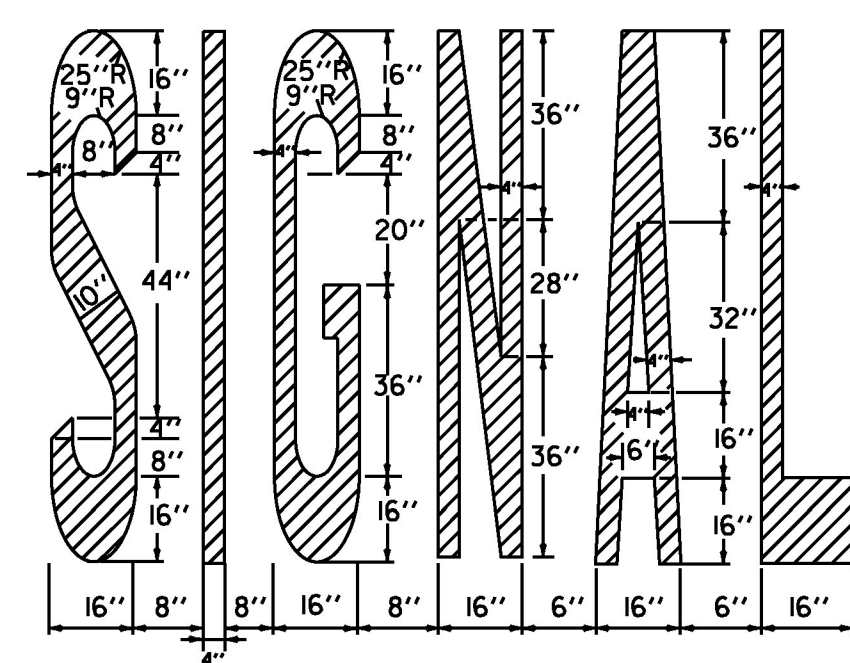

1. TURN ARROWS SHALL BE PLACED AT THE BEGINNING AND END OF THE LEFT OR RIGHT TURN LANE.
2. IF LANE LENGTH IS LESS THAN 100', TURN ARROWS SHOULD BE PLACED AT THE BEGINNING AND END OF THE LEFT OR RIGHT TURN LANE.

5. STOP BARS ARE INSTALLED ONLY WHERE A STOP SIGN OR TRAFFIC SIGNAL ARE LOCATED; STOP LETTERS ARE OPTIONAL. IF INSTALLED THEY SHALL BE 4' FROM THE STOP BAR.

3. THE "ONLY" WORD MARKINGS SHALL BE USED TO SUPPLEMENT LANE-USE ARROW MARKINGS FOR TURN LANES 100' OR LONGER.

6. THE LONGITUDINAL SPACE BETWEEN WORD OR SYMBOL MESSAGE MARKINGS, SHOULD BE AT LEAST FOUR TIMES THE HEIGHT OF THE CHARACTERS FOR LOW SPEED ROADS, BUT NOT MORE THAN TEN TIMES THE HEIGHT OF THE CHARACTERS UNDER ANY CONDITIONS.

4. MORE ARROWS AND ONLY'S ARE OPTIONAL WHEN SPACE PERMITS. ARROW MARKINGS START AT THE BEGINNING OF THE SOLID LANE LINE.

7. EXCLUSIVE TURN LANE LINES (LEFT OR RIGHT) SHALL BE SOLID AND EXTEND BACK FROM THE STOP LINE TO THE POINT OF FULL LANE WIDTH OF THE TURN LANE. 3' DOTS WITH A 9' SPACE SHOULD BE EXTENDED THE FULL LENGTH OF THE LANE TAPER.

TYPICAL MARKINGS FOR TURN LANES

NOT TO SCALE

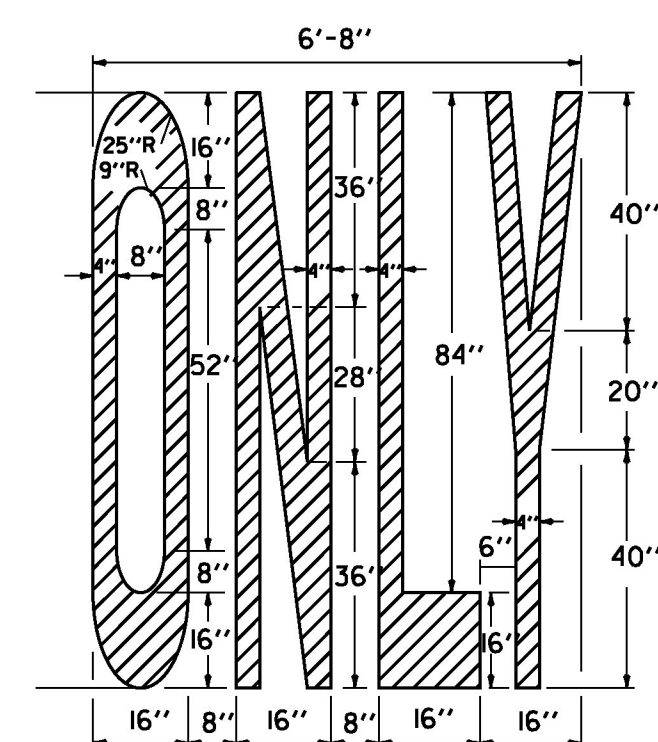

PAVEMENT MARKING DETAILS

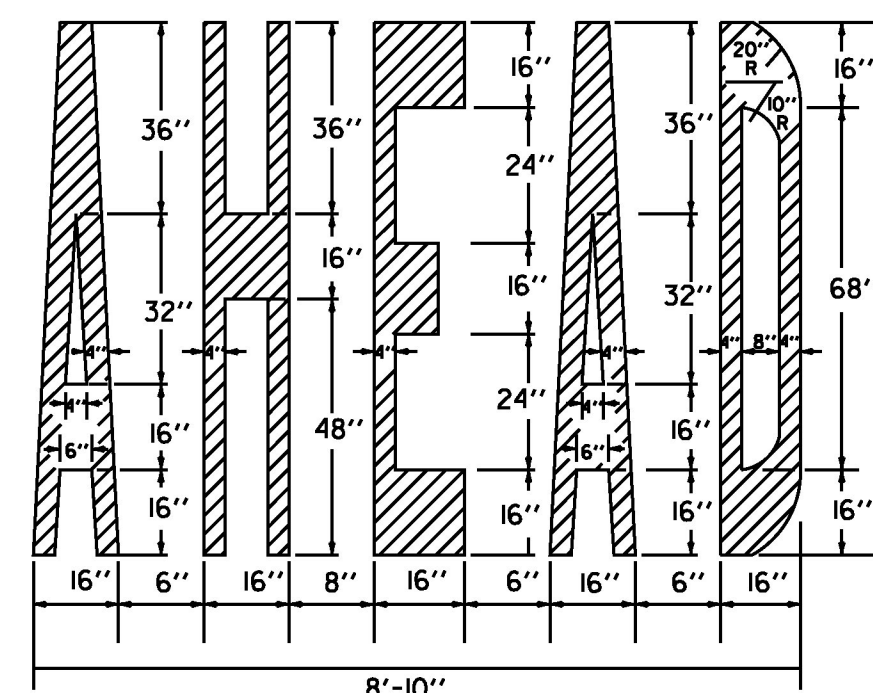

BLUE BACKGROUND
36" X 36" FOR MINIMUM
48" X 48" FOR STANDARD

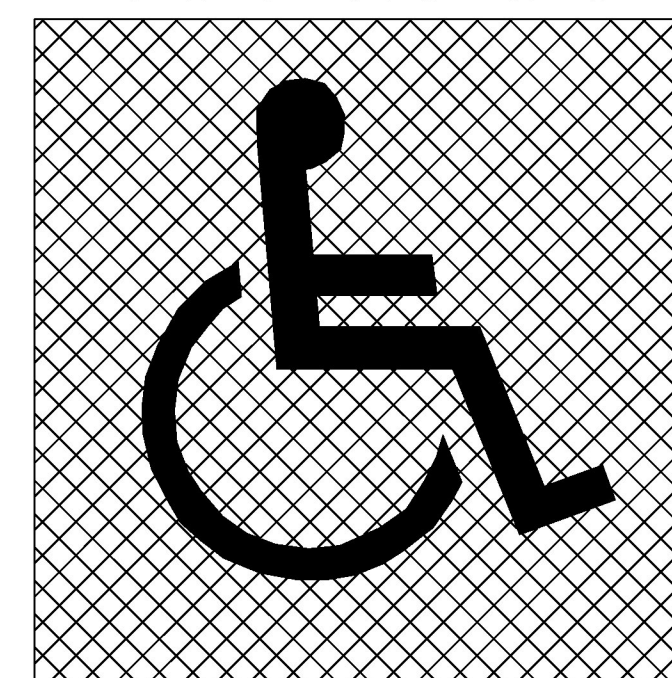

WIDTH OF SYMBOL MINIMUM 24"
STANDARD 36"

HEIGHT OF SYMBOL
MINIMUM 28"
STANDARD 41"

HANDICAPPED SYMBOL WITH BLUE BACKGROUND
TO BE PAID AS TWO SYMBOLS
WITHOUT BLUE BACKGROUND TO BE PAID AS
ONE SYMBOL

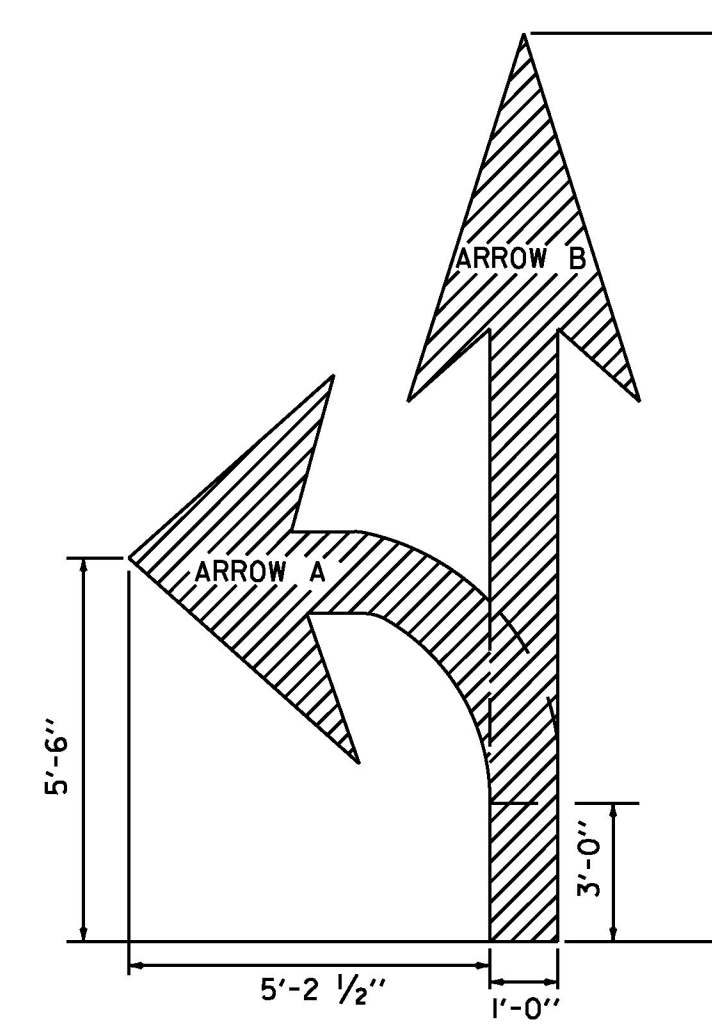

TO BE PAID AS TWO SYMBOLS

ARROW DETAILS

PROJECT NAME:	STATEWIDE
PROJECT NUMBER:	IMG MARK(116)
FILE NAME:	z16+084.dgn
PROJECT LEADER:	C. LATHROP
DESIGNED BY:	P. DAY
TYPICAL PAVEMENT MARKINGS SHEET 1	CHECKED BY: C. LATHROP
	PLOT DATE: 1/23/2017
	DRAWN BY: P. DAY
	SHEET 3 OF 34