

TEMPORARY 6 INCH YELLOW LINE, PAINT
 EXIT 15
 NB OFF RAMP STA 6+75 TO 15+70 SOLID LT
 NB ON RAMP STA 0+00 TO 15+60 SOLID LT
 DURABLE 6 INCH YELLOW LINE, POLYUREA
 EXIT 15
 NB OFF RAMP STA 6+75 TO 15+70 SOLID LT
 NB ON RAMP STA 0+00 TO 15+60 SOLID LT

TEMPORARY 6 INCH WHITE LINE, PAINT
 EXIT 15
 NB OFF RAMP STA 0+00 TO 4+25 LT DOTTED LANE LINE
 NB OFF RAMP STA 0+00 TO 15+70 SOLID RT
 NB ON RAMP STA 0+00 TO 15+60 SOLID RT
 NB ON RAMP STA 8+95 TO 15+60 RT DOTTED LANE LINE
 DURABLE 6 INCH WHITE LINE, POLYUREA
 EXIT 15
 NB OFF RAMP STA 0+00 TO 4+25 LT DOTTED LANE LINE
 NB OFF RAMP STA 0+00 TO 15+70 SOLID RT
 NB ON RAMP STA 0+00 TO 15+60 SOLID RT
 NB ON RAMP STA 8+95 TO 15+60 RT DOTTED LANE LINE

TEMPORARY 12 INCH WHITE LINE, PAINT
 EXIT 15
 MAINLINE (GORE STRIPES) SOLID LT
 NB OFF RAMP STA 4+65 TO 6+75 SOLID LT
 NB ON RAMP STA 4+50 TO 8+95 SOLID LT
 DURABLE 12 INCH WHITE LINE, POLYUREA
 EXIT 15
 MAINLINE (GORE STRIPES) SOLID LT
 NB OFF RAMP STA 4+65 TO 6+75 SOLID LT
 NB ON RAMP STA 4+50 TO 8+95 SOLID LT

TEMPORARY LETTER OR SYMBOL, PAINT
 EXIT 15
 NB OFF RAMP STA 10+42 - "STOP"
 NB OFF RAMP STA 10+58 - "AHEAD"
 NB OFF RAMP STA 15+56 - "STOP"
 NB OFF RAMP*

TEMPORARY 24 INCH STOP BAR, PAINT
 EXIT 15
 NB OFF RAMP STA 15+62
 DURABLE 24 INCH STOP BAR (OPTION ITEM)
 EXIT 15
 NB OFF RAMP STA 15+62

DURABLE LETTER OR SYMBOL (OPTION ITEM)
 EXIT 15
 NB OFF RAMP STA 10+42 - "STOP"
 NB OFF RAMP STA 10+58 - "AHEAD"
 NB OFF RAMP STA 15+56 - "STOP"
 NB OFF RAMP*

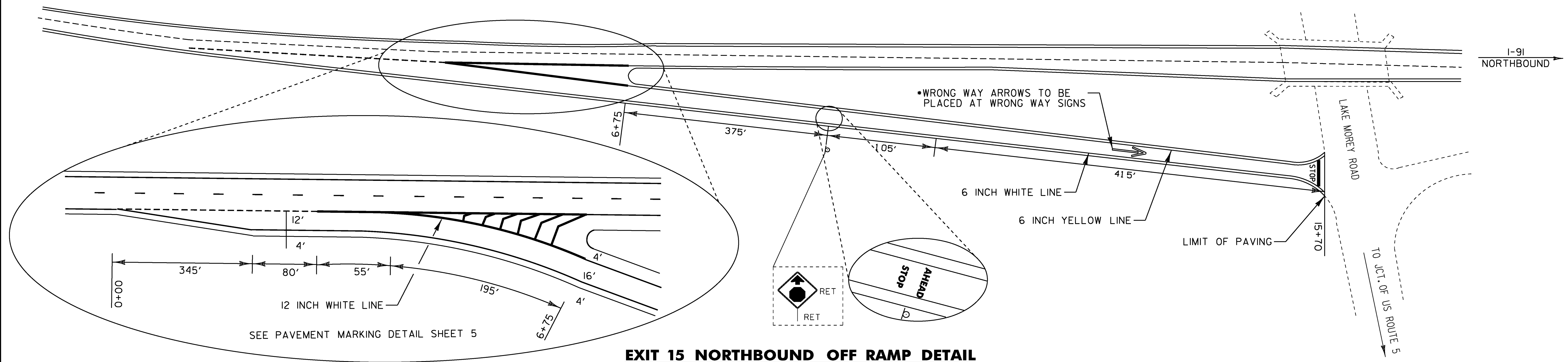

EXIT 15 NORTHBOUND OFF RAMP DETAIL

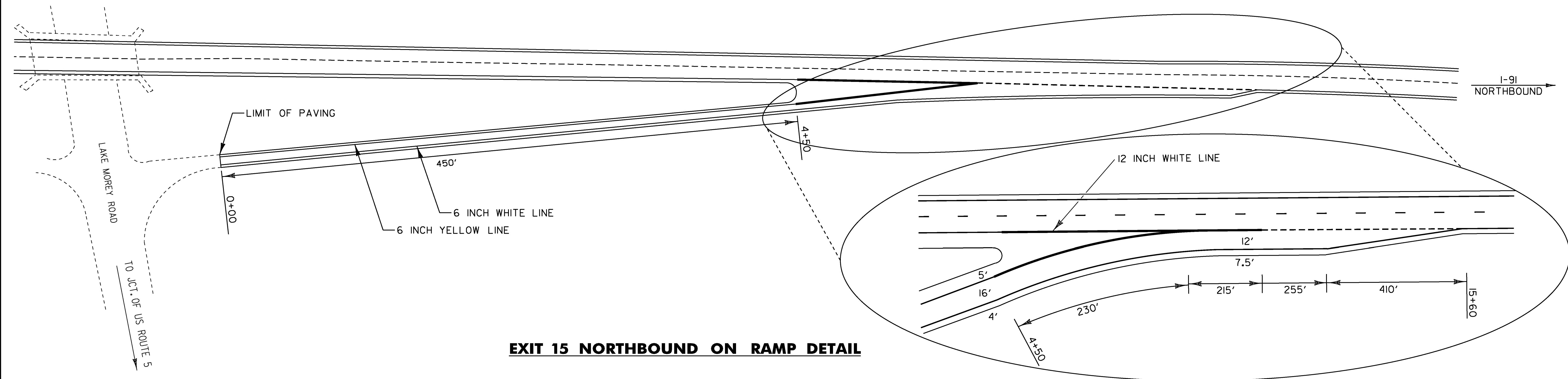

EXIT 15 NORTHBOUND ON RAMP DETAIL

NOTE: SEE PAVEMENT MARKING DETAIL SHEET 5 FOR ADDITIONAL MARKING DETAILS

NOT TO SCALE

PROJECT NAME: NORWICH - FAIRLEE	PLOT DATE: 19-DEC-2014
PROJECT NUMBER: IM SURF(48)	DRAWN BY: N. PAPPAS
FILE NAME: I4a144 Norwich-Fairlee.dgn	CHECKED BY: J. HARRINGTON
PROJECT LEADER: J. HARRINGTON	PAVEMENT MARKING DETAIL SHEET 4
DESIGNED BY: N. PAPPAS	SHEET 17 OF 22