

TYPICAL APPROACH AREA DETAIL MAINLINE & RAMPS

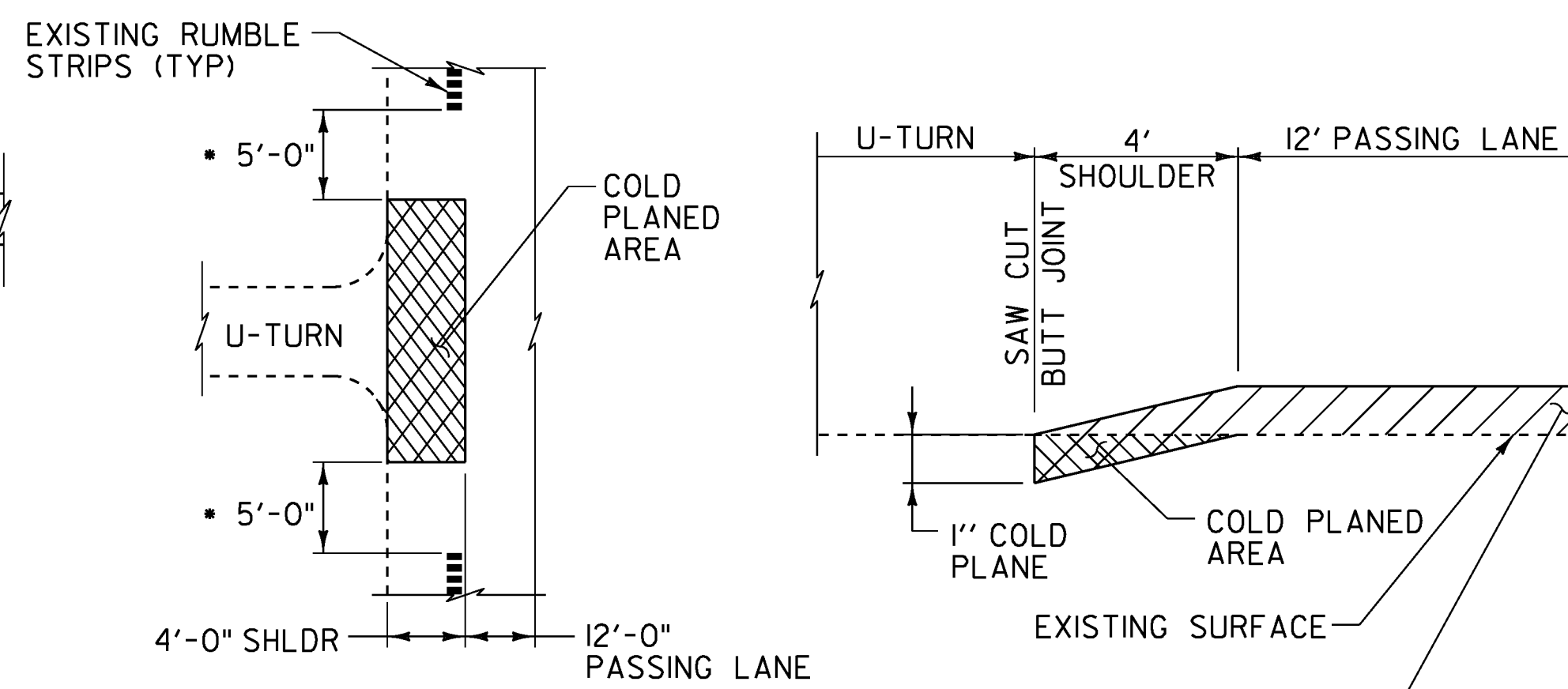

- BEGIN COLD PLANING 5'-0" AFTER RUMBLE STRIPS END, AND END COLD PLANING 5'-0" BEFORE RUMBLE STRIPS BEGIN

COLD PLANE DETAIL AT U-TURNS

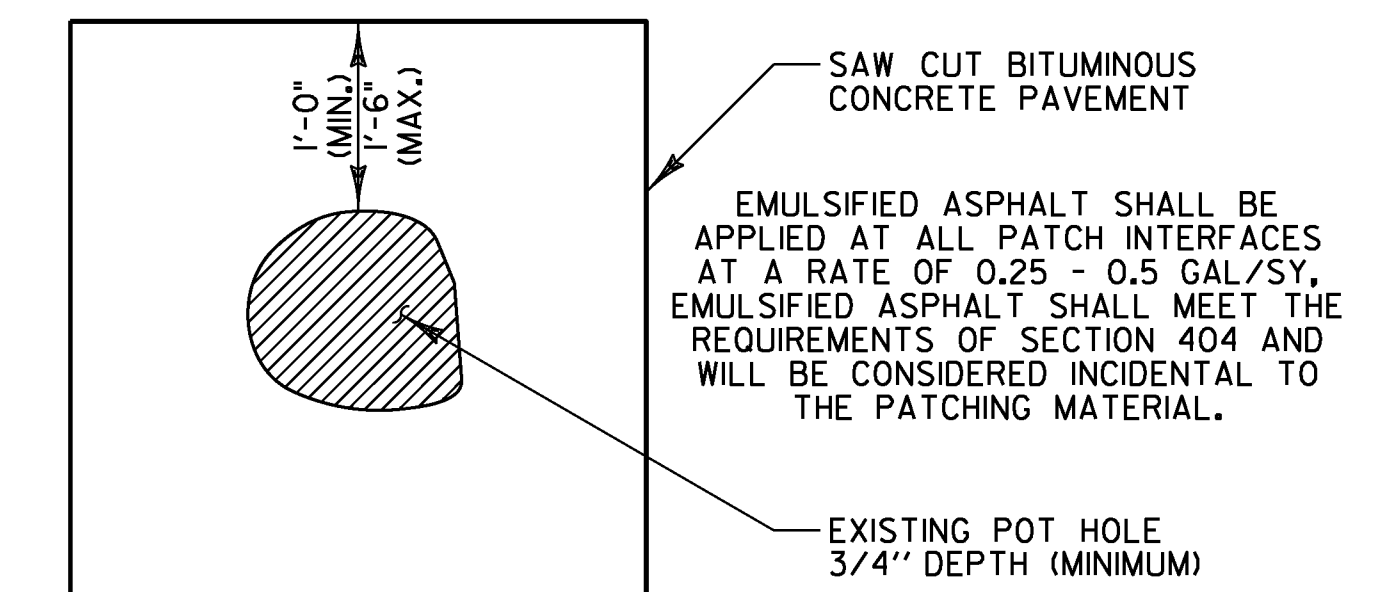

TYPICAL POT HOLE REPAIR

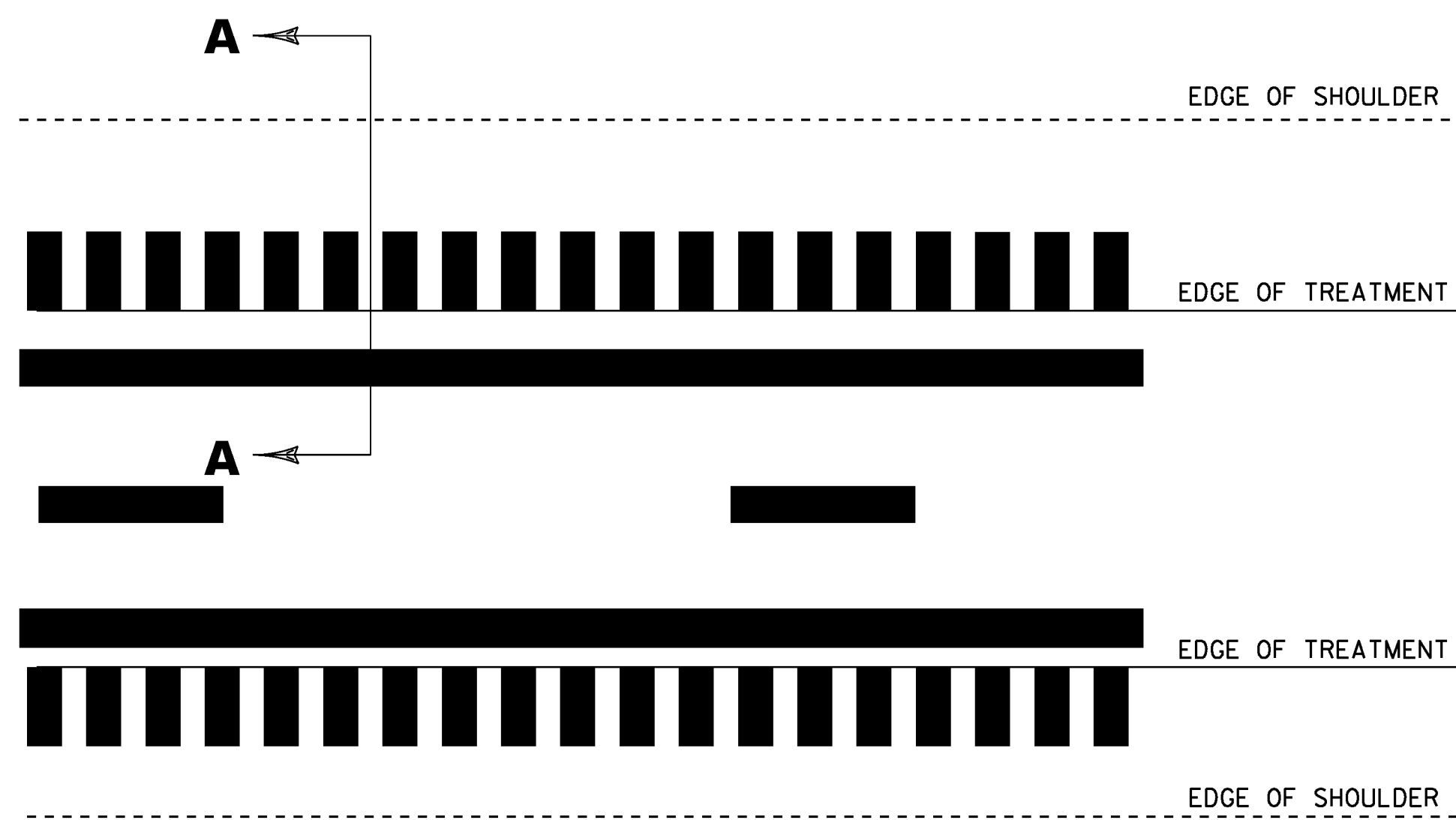

EDGE OF TREATMENT TYPICAL PLAN

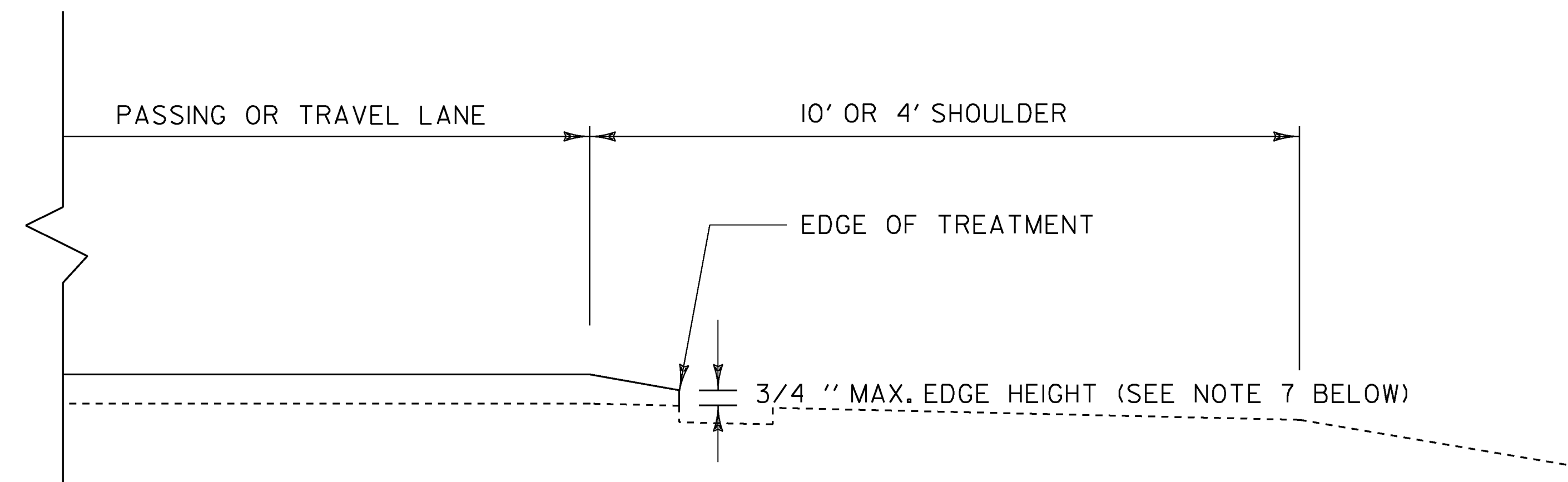

EDGE OF TREATMENT TYPICAL SECTION A-A

NOTES:

1. ALL NECESSARY SURFACE PREPARATION INVOLVING PATCHING, POTHOLE REPAIR, AND CRACK-SEALING SHALL BE PERFORMED PRIOR TO APPLICATION OF THE FINAL SURFACE TREATMENT. ALL CRACKS GREATER THAN 0.10" AND UP TO 1.0" IN WIDTH SHALL BE SEALED USING THE "BLOW AND GO" FILL METHOD. ALL COSTS ASSOCIATED WITH THIS WORK SHALL BE PAID FOR UNDER ITEM 417.20, BITUMINOUS CRACK SEALING, "BLOW AND GO" METHOD. THE PATCHING OF ALL CRACKS GREATER THAN 1.0" AND ALL OTHER PATCHING AND POTHOLE REPAIR SHALL BE COMPLETED USING BITUMINOUS CONCRETE PAVEMENT IN ACCORDANCE WITH ITEM 900.680 SPECIAL PROVISION (BITUMINOUS CONCRETE PAVEMENT SURFACE PREPARATION, TYPE I). AN ESTIMATED QUANTITY FOR THIS ITEM HAS BEEN INCLUDED TO COVER ALL COSTS ASSOCIATED WITH THIS WORK.
2. EXISTING SHOULDER PAVEMENT SURFACES BEYOND THE LIMITS OF THE FINAL SURFACE TREATMENT SHALL ALSO RECEIVE CRACK-SEALING AND RELATED PATCHING AND POTHOLE REPAIR TREATMENTS.
3. FOLLOWING COMPLETION OF COLD PLANING, THE MILLED SURFACE FOR ALL BRIDGES TO BE COLD PLANED SHALL ALSO RECEIVE CRACK-SEALING AND RELATED PATCHING AND POTHOLE REPAIR TREATMENTS, AS DIRECTED BY THE ENGINEER.
4. ALL EXISTING PAVEMENT MARKINGS SHALL BE REMOVED PRIOR TO ANY CRACK SEALING BEING PERFORMED AND PRIOR TO APPLYING THE FINAL SURFACE TREATMENT. ALL LANE DELINEATION IS TO BE MAINTAINED DURING CONSTRUCTION BY THE USE OF LINE STRIPING TARGETS OR TEMPORARY PAINT.
5. A 50' COLD PLANED WEDGE SHALL BE CONSTRUCTED AT THE PROJECT BEGIN, PROJECT END, RAMPS, AND AT ALL BRIDGE APPROACHES OR AS DIRECTED BY THE ENGINEER. THE LONGITUDINAL EDGES OF THE SURFACE TREATMENT SHALL BE FEATHERED AS SHOWN ON THE TYPICAL SECTION, OR AS DIRECTED BY THE ENGINEER. ANY SAWCUTTING AT BUTT JOINTS SHALL BE PAID INCIDENTAL TO ITEM 900.675 SPECIAL PROVISION, MICRO-MILLING BITUMINOUS CONCRETE PAVEMENT.
6. THERE ARE R.W.I.S. SENSORS IN THE PAVEMENT AT APPROXIMATE MM 84.270 NORTHBOUND THAT MAY BE IMPACTED BY CONSTRUCTION ACTIVITIES. THE CONTRACTOR SHALL CONTACT MARK GERRISH, FIBER OPTIC PROJECT MANAGER, VTRANS OPERATIONS AND MAINTENANCE BUREAU AT 802-461-5570 48 HOURS PRIOR TO BEGINNING ANY WORK IN THIS AREA SO THAT MARK OR HIS REPRESENTATIVE CAN REMOVE THESE SENSORS. INSTALLATION OF NEW SENSORS WILL BE PERFORMED BY OTHERS FOLLOWING COMPLETION OF THE PROJECT. THERE IS A WEIGH IN MOTION SENSOR IN THE PAVEMENT AT APPROXIMATE MM 91.05 NORTHBOUND THAT MAY BE IMPACTED BY CONSTRUCTION ACTIVITIES. INSTALLATION OF NEW SENSORS WILL BE PERFORMED BY OTHERS FOLLOWING COMPLETION OF THE PROJECT.
7. THE SCREED OF THE PAVER SHALL BREAK AT THE BREAK POINT OF THE SHOULDER SUCH THAT THE DESIGNED NOMINAL THICKNESS IS CARRIED ONTO THE SHOULDER AND BROKEN OR PINCHED BY ROLLING. EDGE HEIGHT SHALL BE MEASURED AT A MINIMUM OF FIVE RANDOMLY SPACED POINTS PER TENTH OF A MILE. IF IT IS FOUND THAT THE AVERAGE EDGE HEIGHT IS GREATER THAN 3/4" OVER THE TENTH OF A MILE, WORK SHALL BE PERFORMED SUCH THAT THE 3/4" AVERAGE HEIGHT IS ACHIEVED. THIS APPLIES TO BOTH THE 10' AND 4' SHOULDER SIDES OF THE HIGHWAY.

NOT TO SCALE

| | |
|---------------------------------------|---------------------------|
| PROJECT NAME: NORWICH - FAIRLEE | PLOT DATE: 19-DEC-2014 |
| PROJECT NUMBER: IM SURF(48) | DRAWN BY: N. PAPPAS |
| FILE NAME: I4a144 Norwich-Fairlee.dgn | CHECKED BY: J. HARRINGTON |
| PROJECT LEADER: J. HARRINGTON | SHEET 5 OF 22 |
| DESIGNED BY: N. PAPPAS | |
| PROJECT NOTES AND DETAILS | |