

**WELD TERMINATION AND COPING  
DETAILS FOR STEEL MEMBERS**

\*NO WELD FOR 3/8" MIN. 7/8" MAX. (EXCEPT MUST MAINTAIN 1" MINIMUM FROM EDGE OF FLANGE)

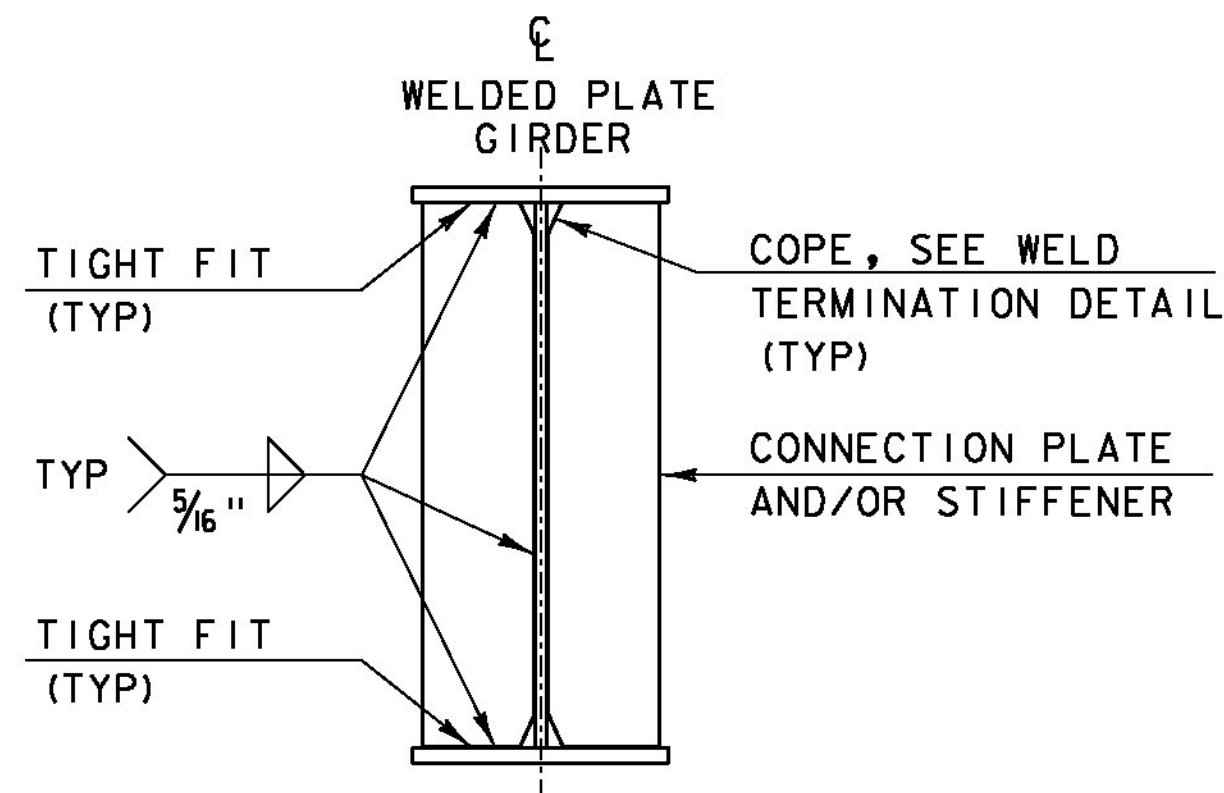

**INTERMEDIATE CONNECTION PLATES  
AND/OR STIFFENERS FOR WELDED  
PLATE GIRDERS**

INTERMEDIATE DETAIL IS ONLY USED WHEN PLATE DOES NOT OCCUR AT AN ABUTMENT OR PIER.

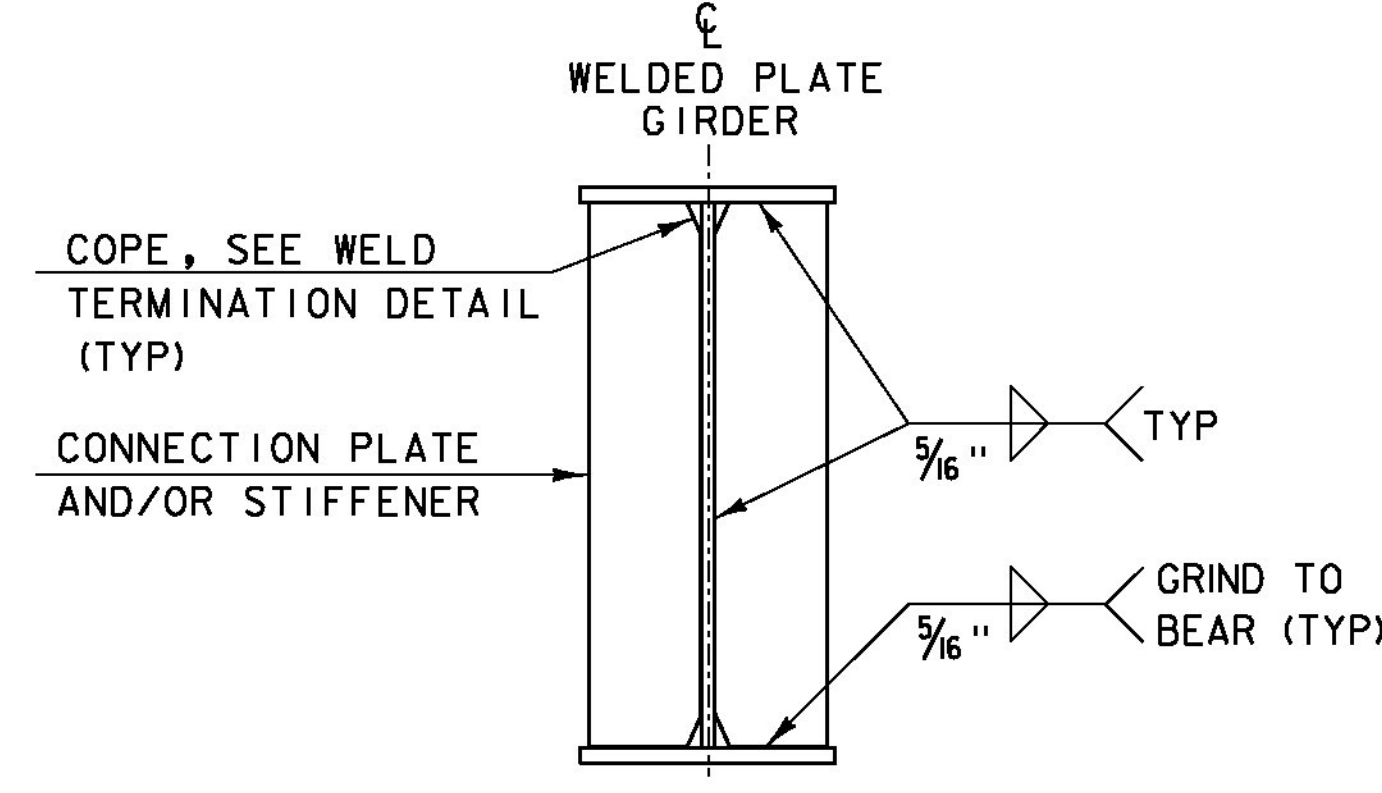

**ABUTMENT BEARING STIFFENERS  
AND/OR CONNECTION PLATES  
FOR WELDED PLATE GIRDERS**

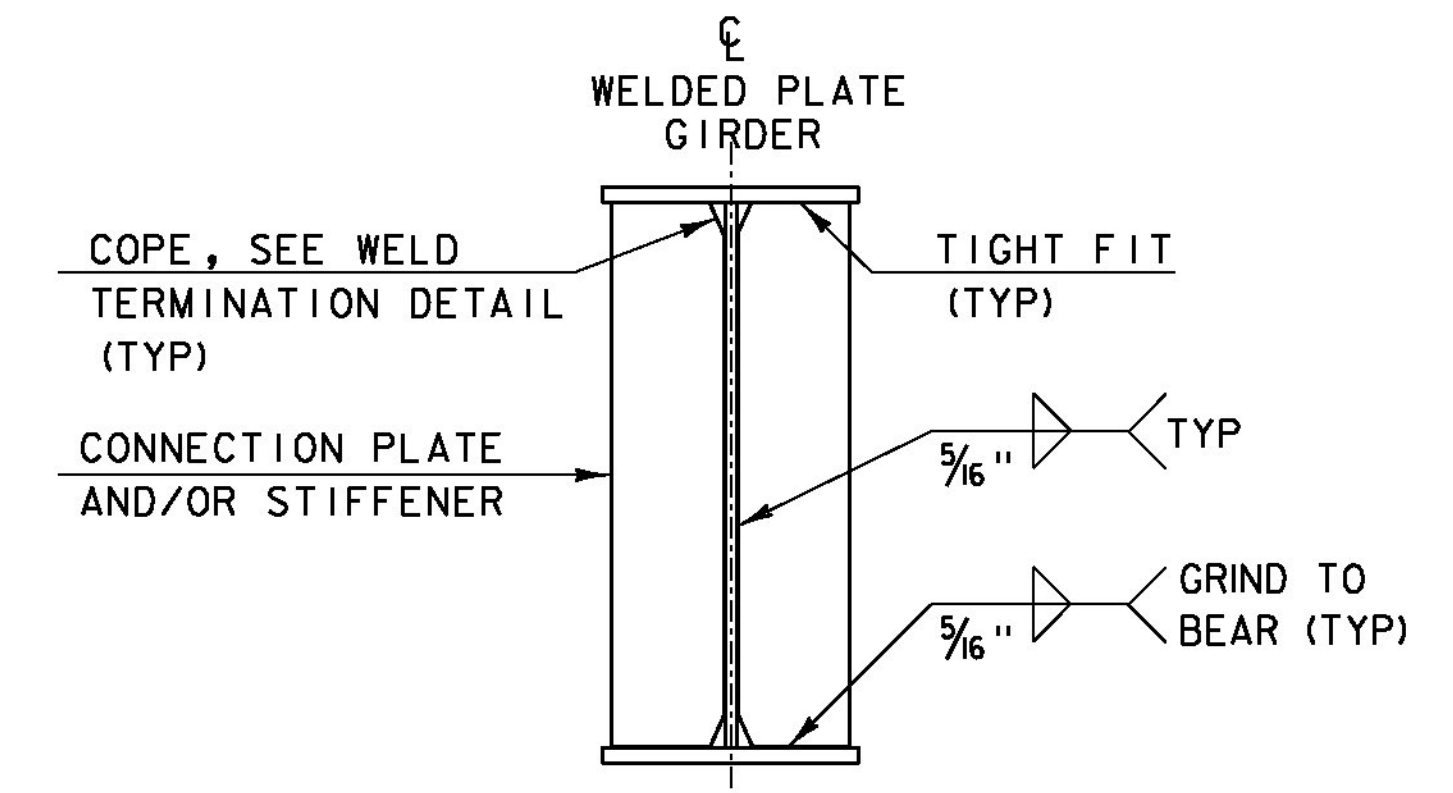

**PIER BEARING STIFFENERS  
AND/OR CONNECTION PLATES  
FOR WELDED PLATE GIRDERS**

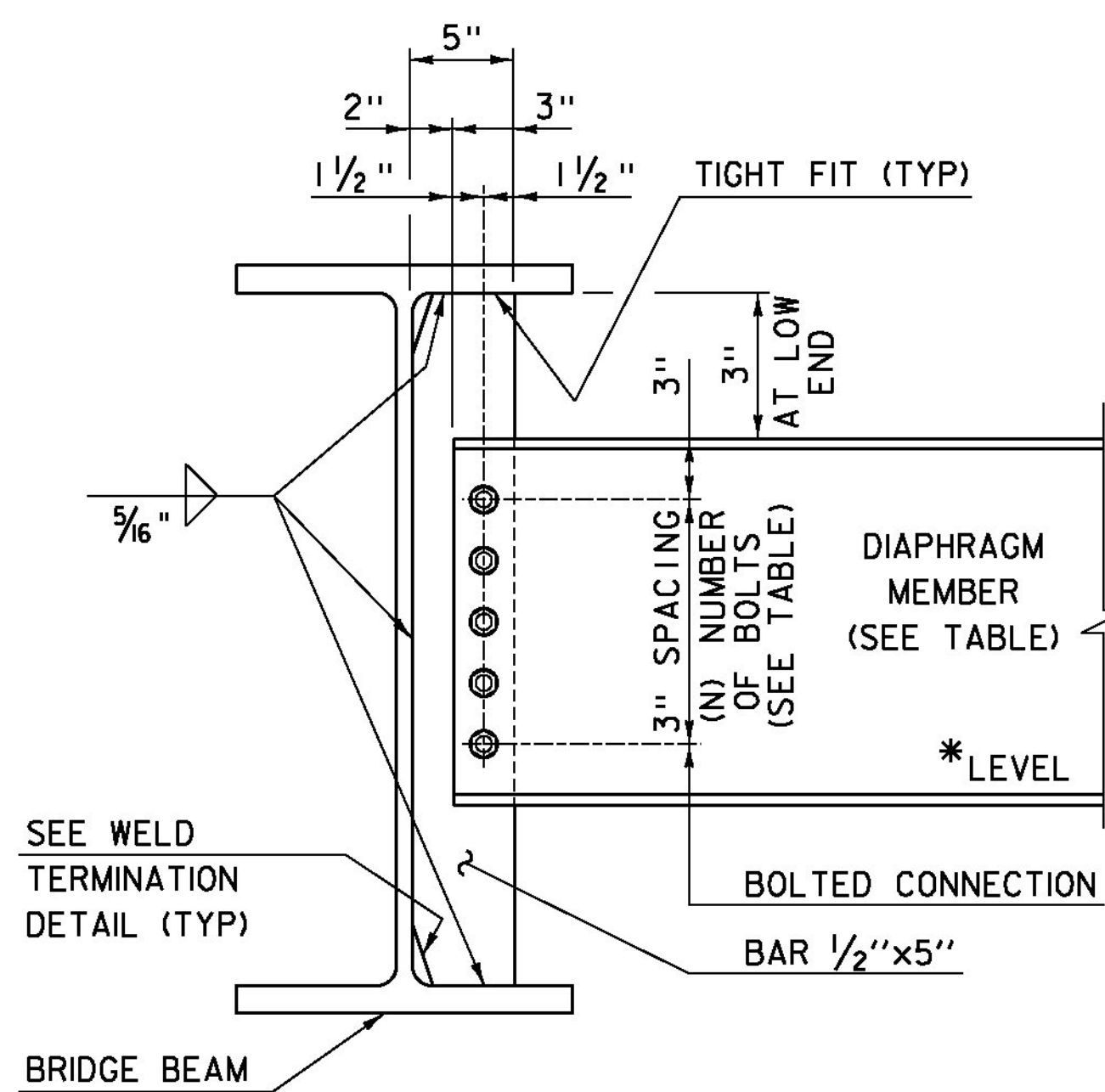

	DEPTH	DIAPHRAGM MEMBER	(N) BOLTS
ROLLED BEAM	24"	C15x33.9	4
	30"		
	31"	MC18x42.7	5
36"			
PLATE GIRDER WEB	37"	W21x44	6
	42"		
PLATE GIRDER WEB	31"	W27x84	7
	36"		
	37"	W33x118	9
	42"		
	43"	W36x135	10
	48"		

**INTERMEDIATE DIAPHRAGMS  
FOR 24" TO 48" BRIDGE BEAMS**

\* IF CLEARANCE CANNOT BE MET, DIAPHRAGM MAY BE SLOPED.

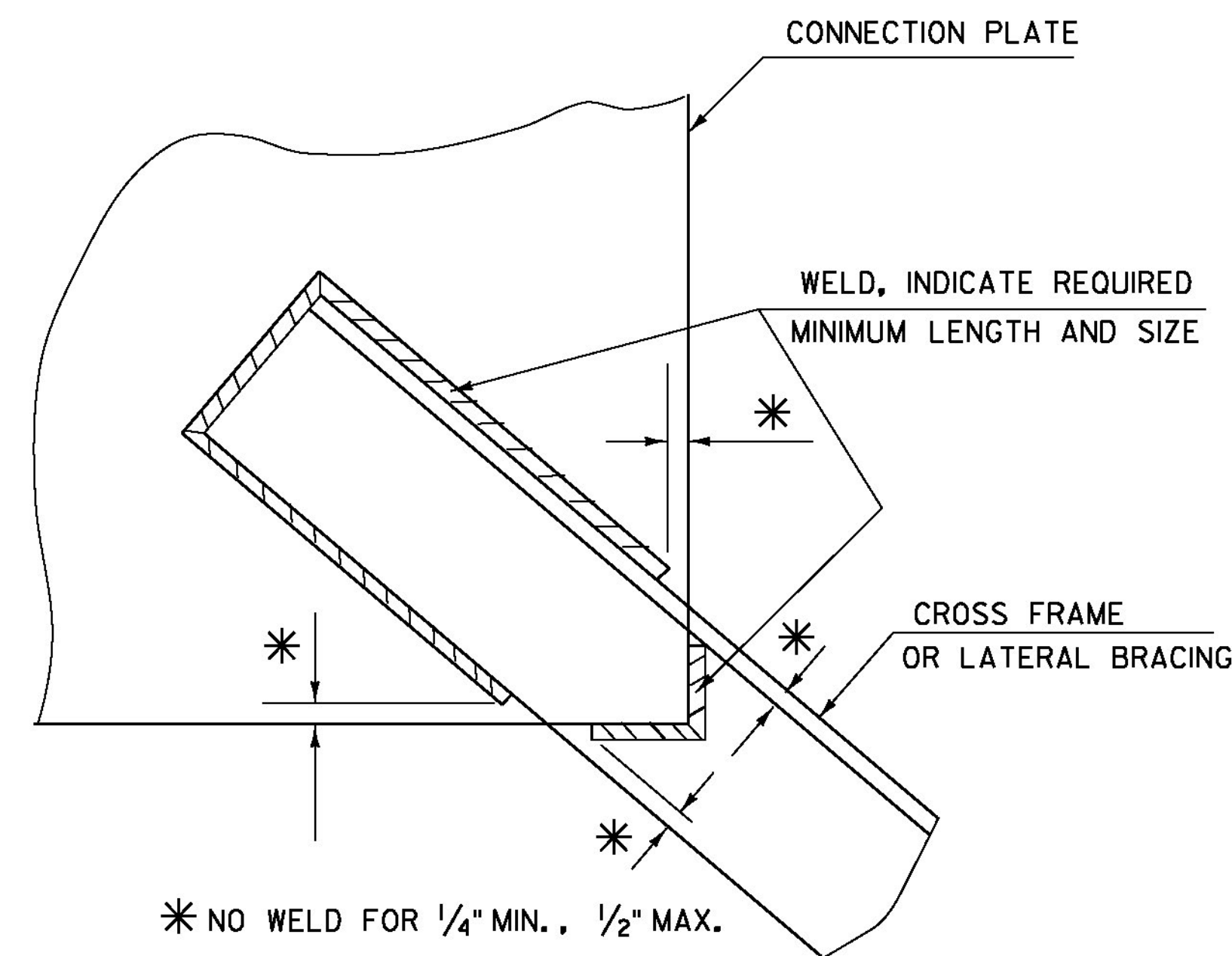

**WELD LOCATION DETAIL AT CROSS  
FRAMES AND LATERAL BRACING**

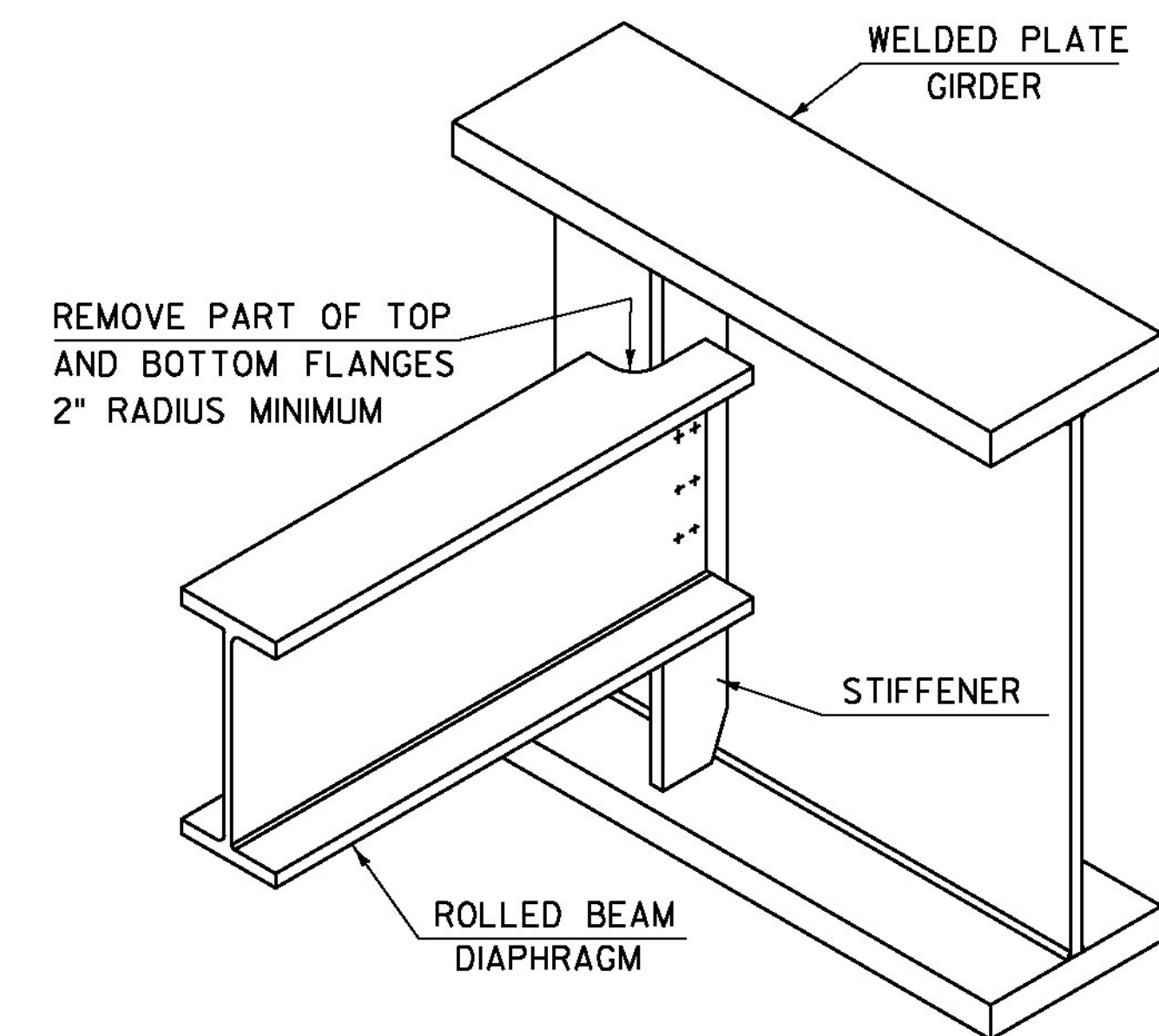

**ROLLED BEAM USED AS DIAPHRAGM**

DETAILS ON THIS SHEET ARE "NOT TO SCALE" UNLESS NOTED OTHERWISE.

REVISIONS	
MAY 7, 2010	APPROVED FOR USE BY VAOT STRUCTURES SECTION
MAY 2, 2011	ADD INTERMEDIATE DIAPHRAGMS DETAIL & ADD NOT TO SCALE NOTE

# STRUCTURAL STEEL PLATE GIRDER DETAILS AND NOTES

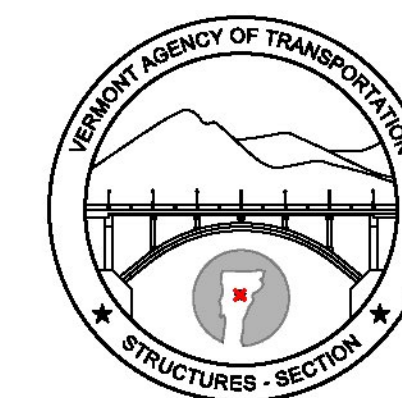

**STRUCTURES  
DETAIL  
SD-602.00**