

TYPICAL PAVEMENT MARKINGS

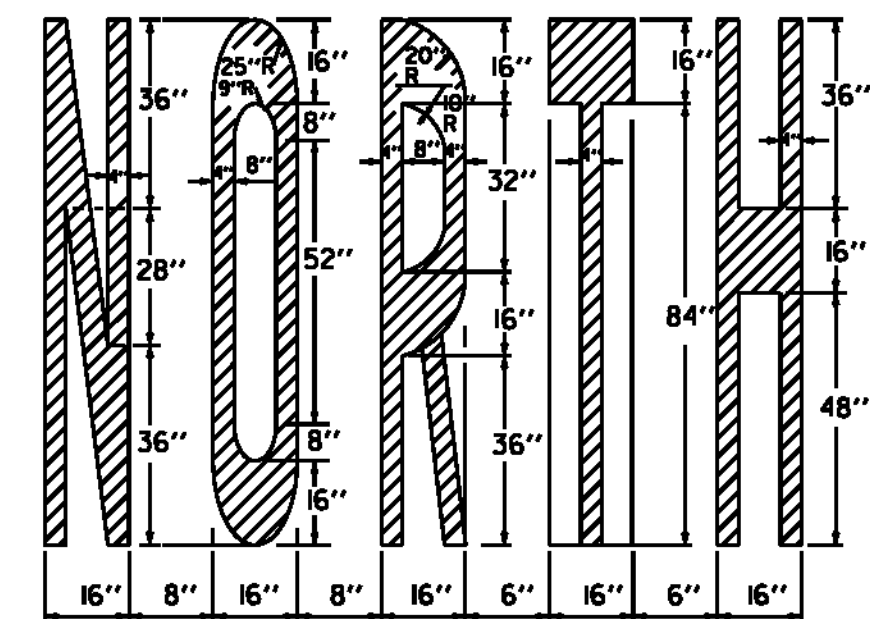

ADJUST TO AVAILABLE PAVEMENT WIDTH

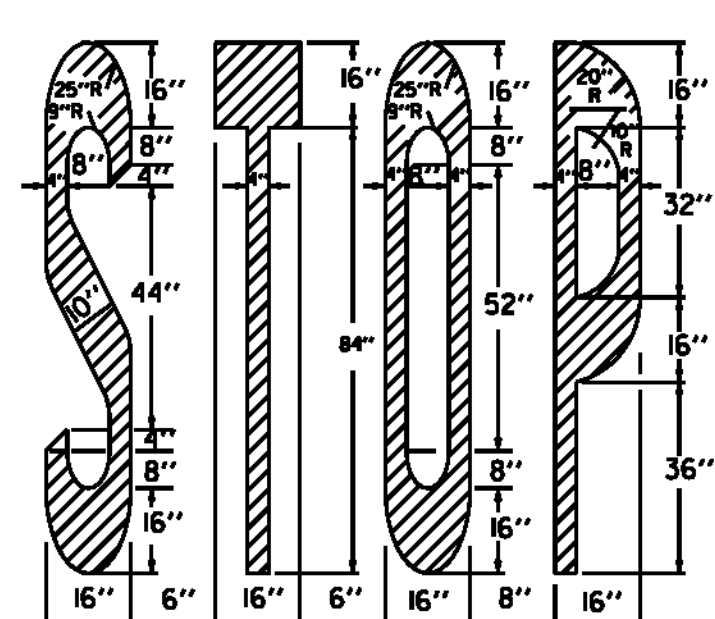

7'-0"

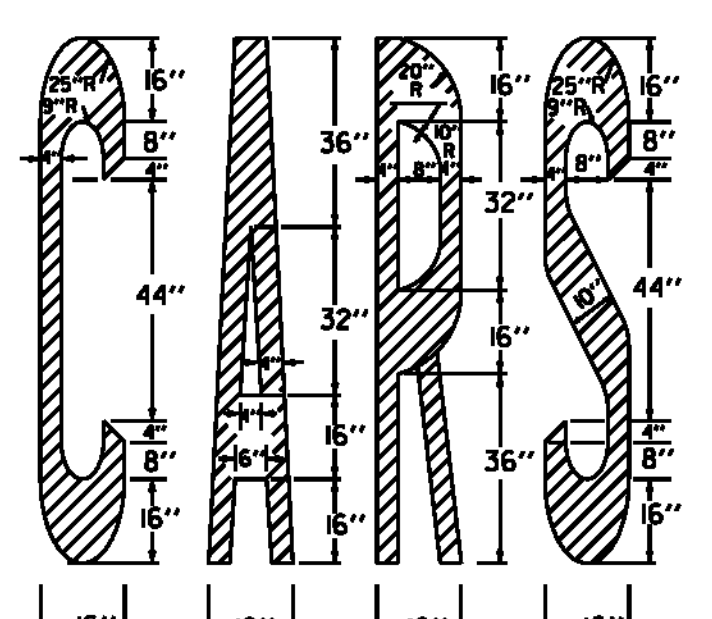

(* 6") - ADJUST TO AVAILABLE PAVEMENT WIDTH

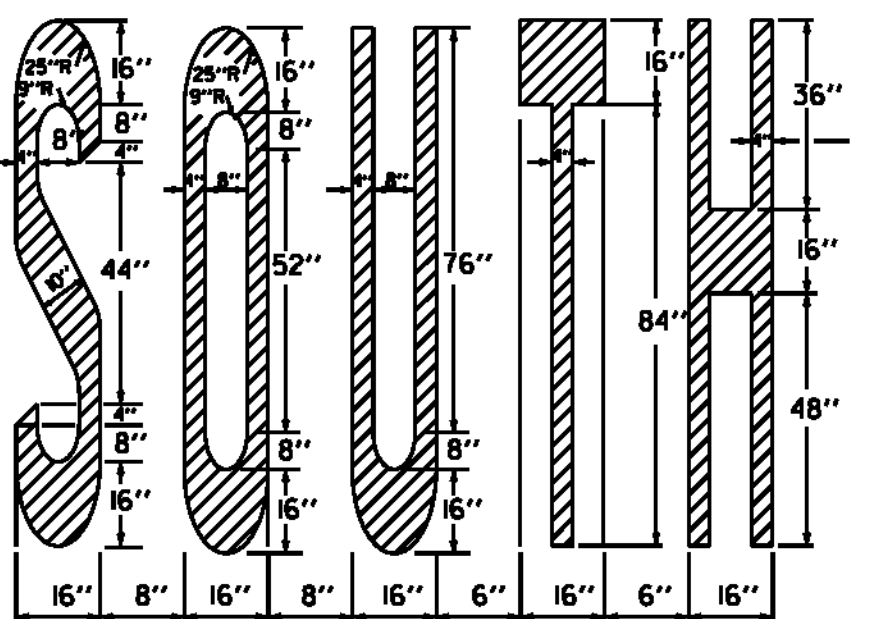

ADJUST TO AVAILABLE PAVEMENT WIDTH

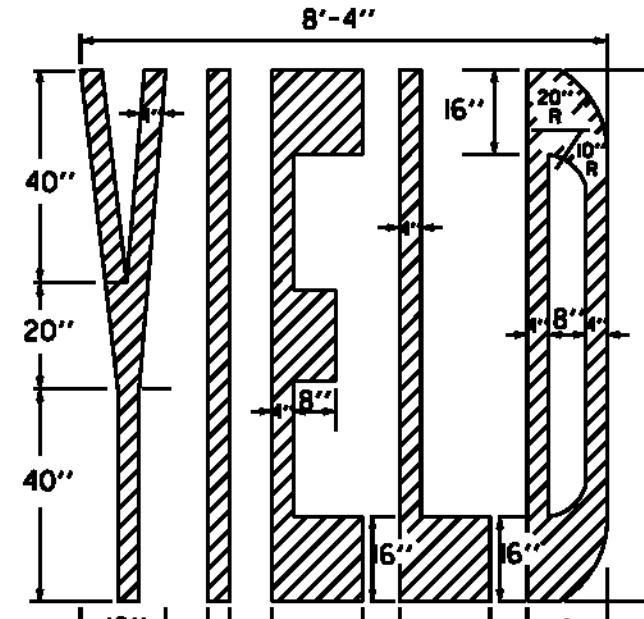

8'-4"

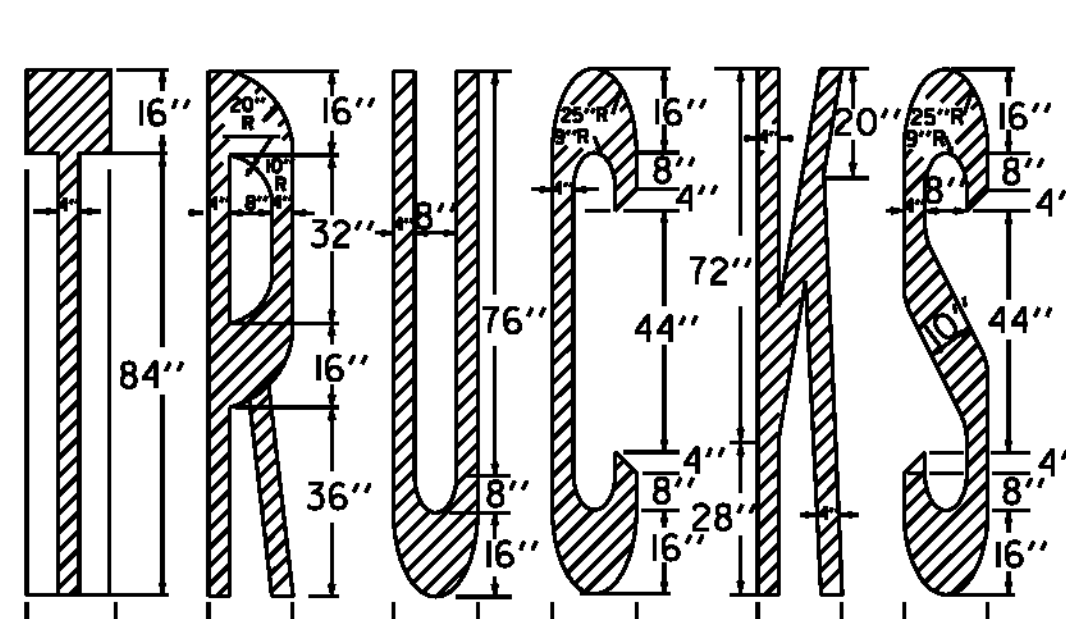

ADJUST TO AVAILABLE PAVEMENT WIDTH

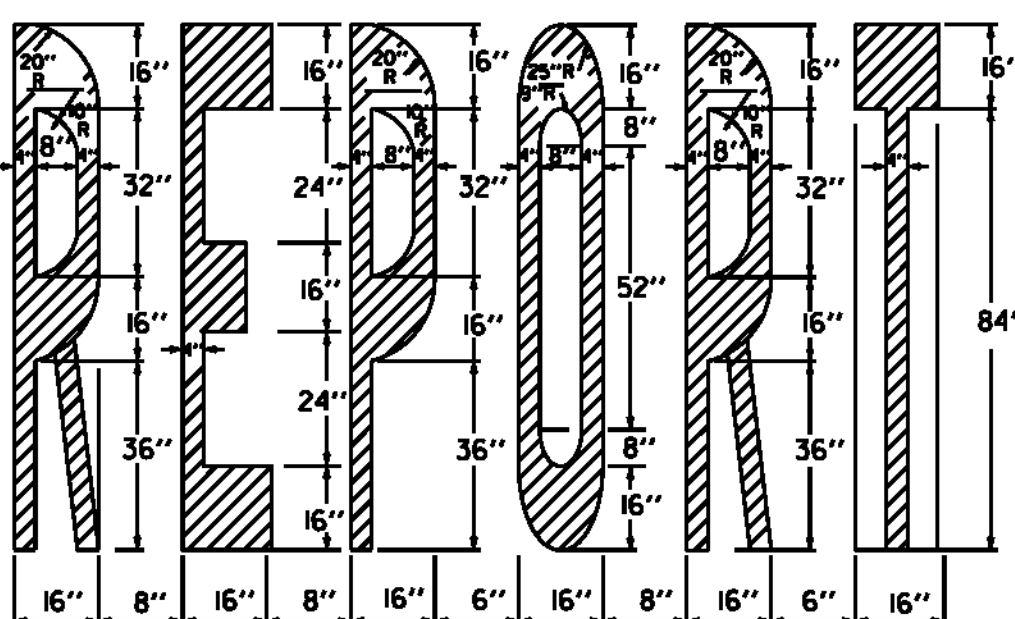

ADJUST TO AVAILABLE PAVEMENT WIDTH

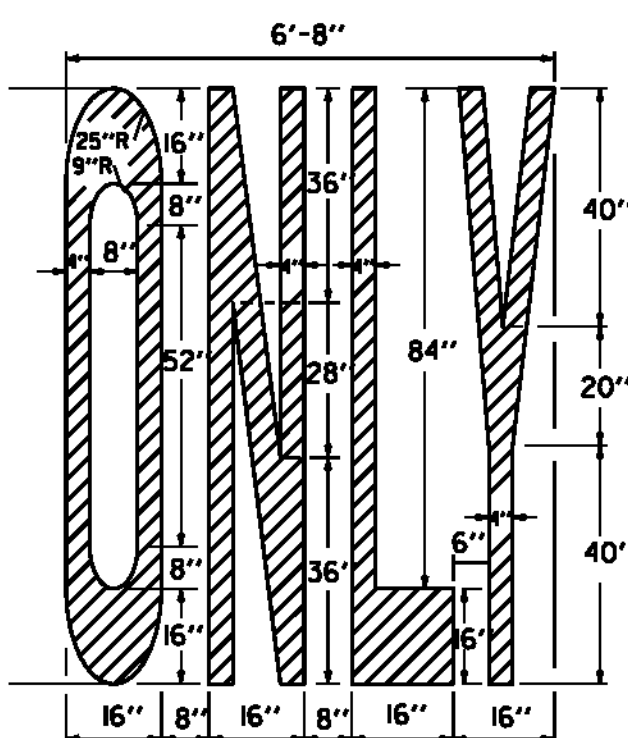
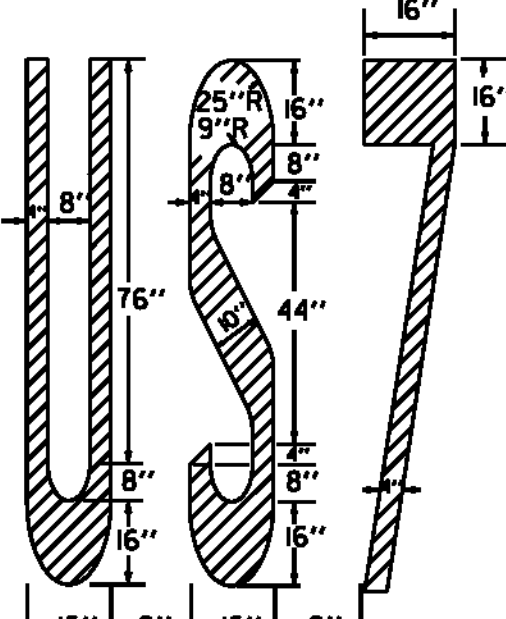
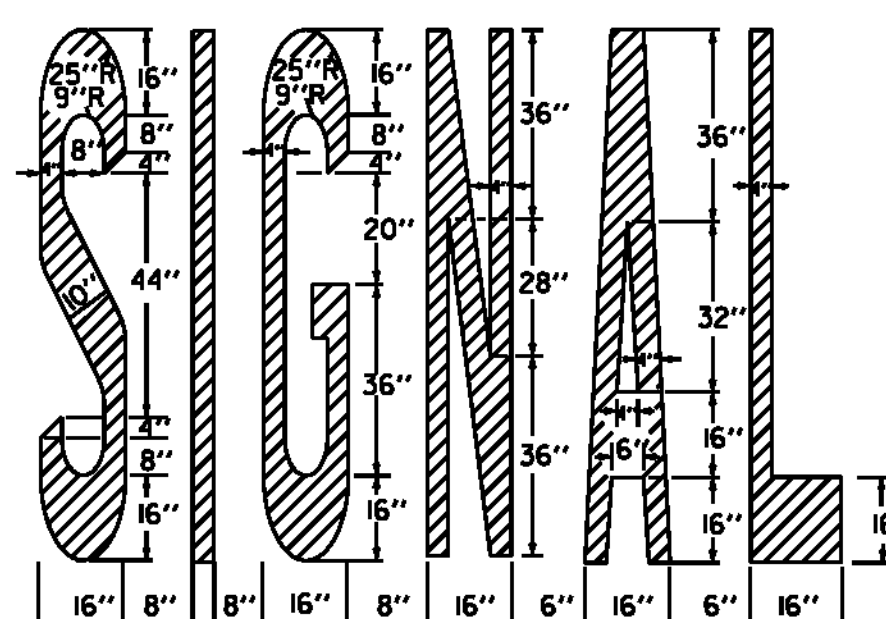

PAVEMENT MARKING DETAILS

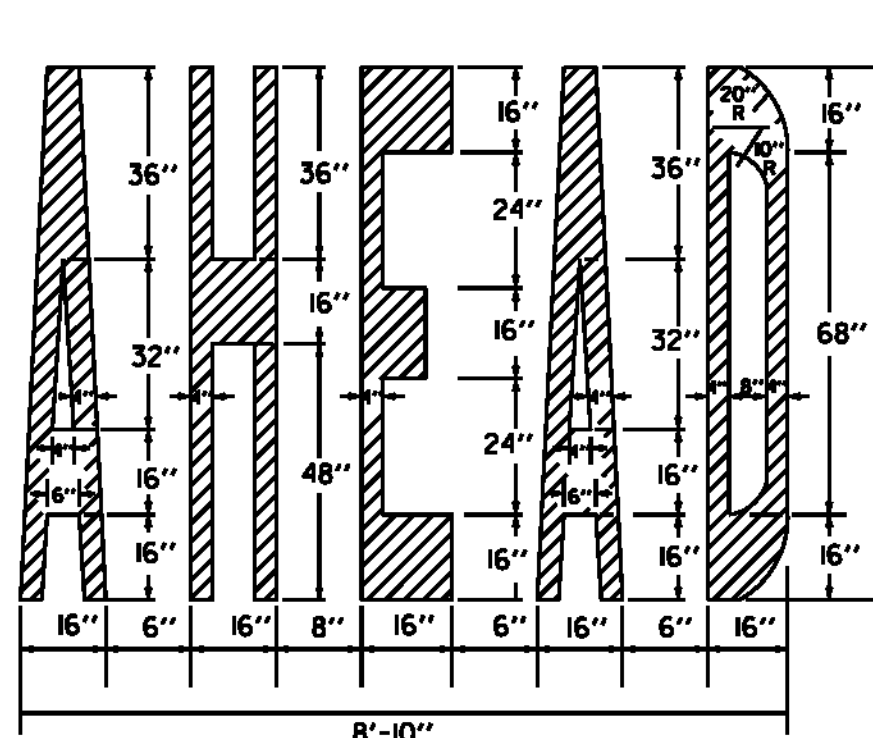

8'-10"

BLUE BACKGROUND
36" X 36" FOR MINIMUM
48" X 48" FOR STANDARD

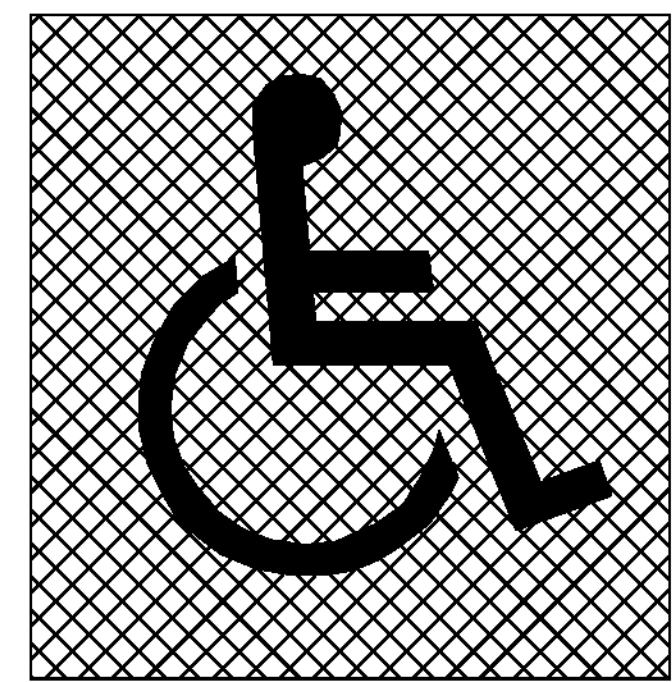

HEIGHT OF SYMBOL
MINIMUM 28"
STANDARD 41"

WIDTH OF SYMBOL MINIMUM 24"
STANDARD 36"

HANDICAPPED SYMBOL WITH BLUE BACKGROUND
TO BE PAID AS TWO SYMBOLS
WITHOUT BLUE BACKGROUND TO BE PAID AS
ONE SYMBOL

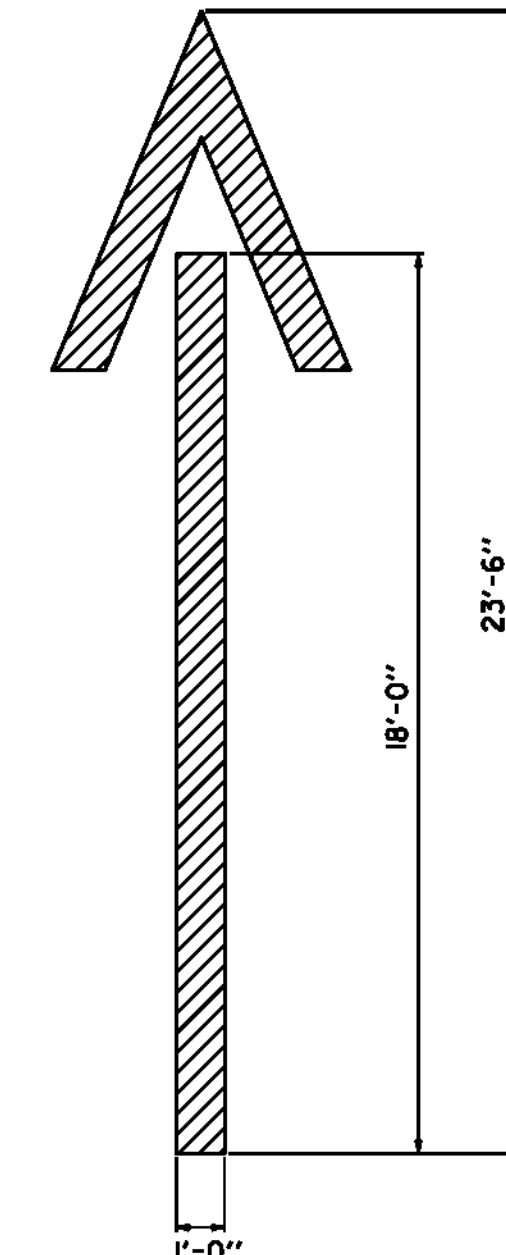
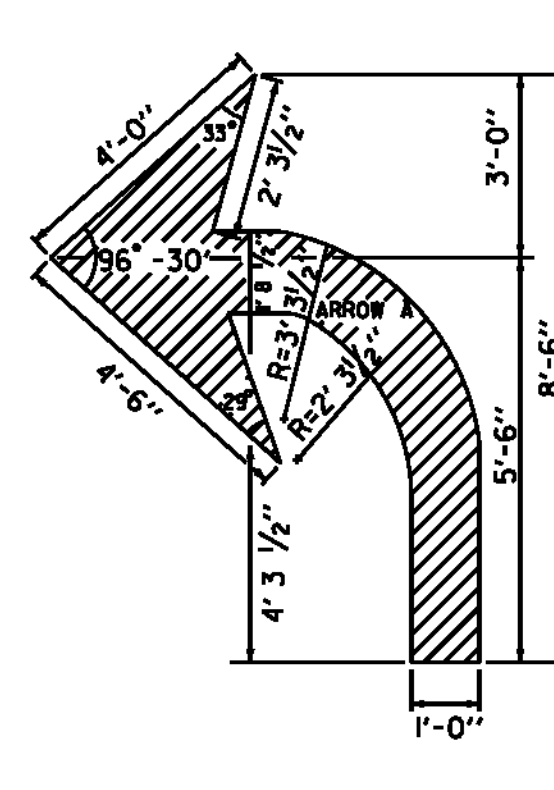
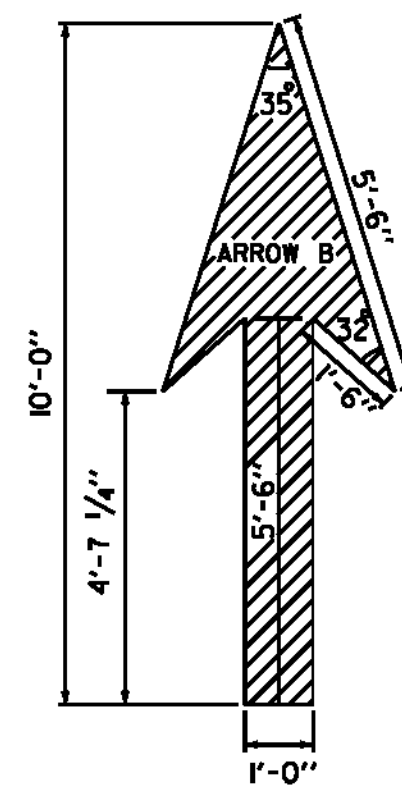

WRONG WAY ARROW

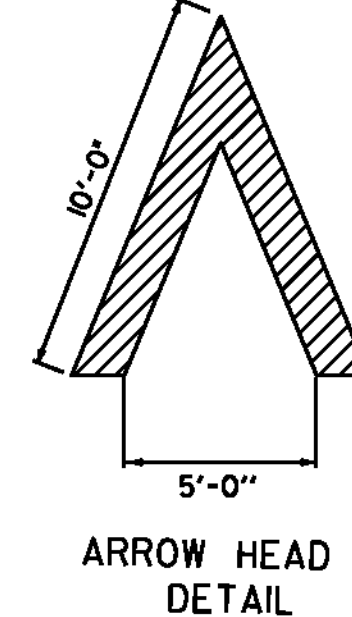

ARROW HEAD
DETAIL

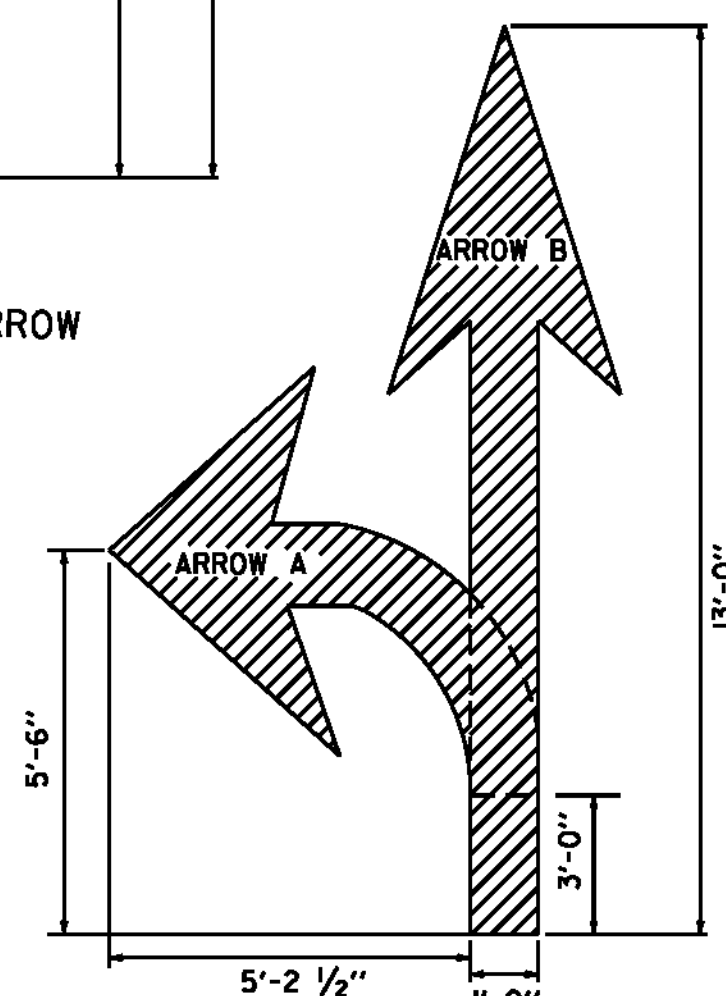

TO BE PAID AS TWO SYMBOLS

ARROW DETAILS

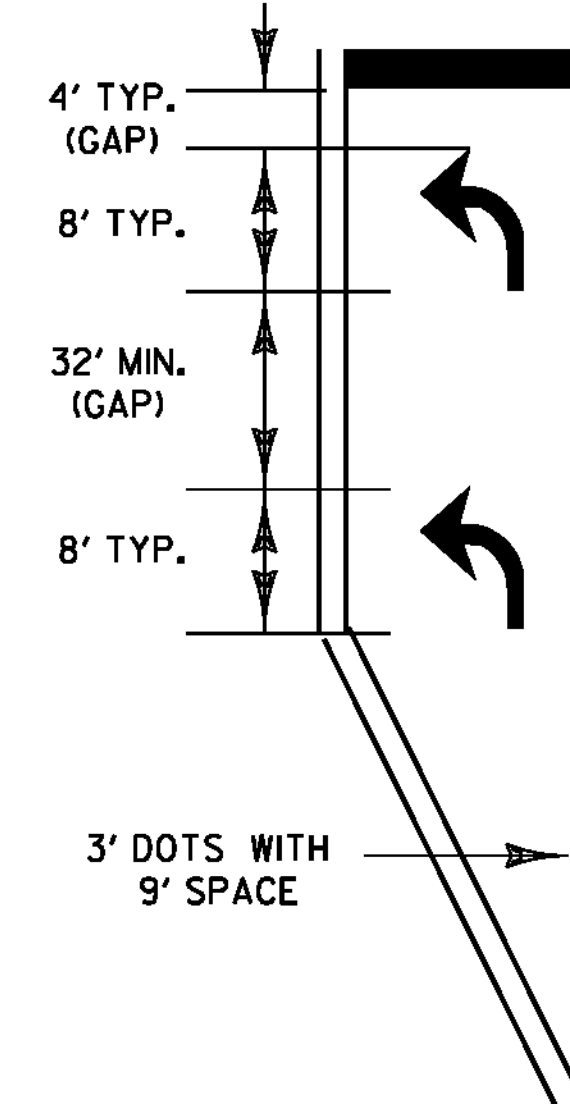

50'-100' TYP.
TURN LANE

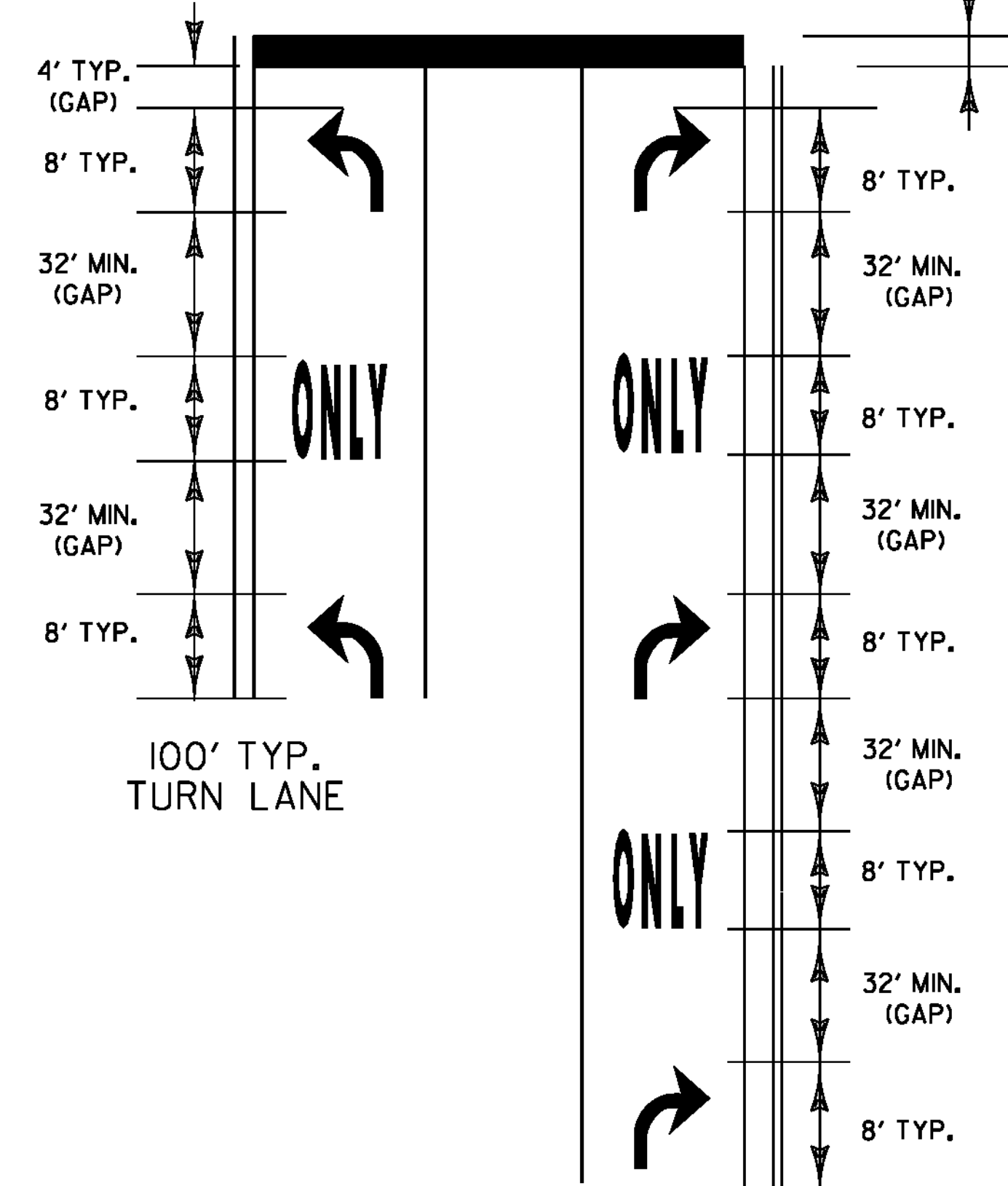

100' TYP.
TURN LANE

200' TYP.
TURN LANE

TURN ARROWS SHALL BE PLACED
AT THE BEGIN AND END OF THE
LEFT OR RIGHT TURN LANE.

IF LANE LENGTH IS LESS THAN
100', TURN ARROWS SHOULD BE
PLACED AT THE BEGINNING AND
END OF THE LEFT OR RIGHT
TURN LANE.

THE 'ONLY' WORD MARKINGS SHALL
BE USED TO SUPPLEMENT LANE-USE
ARROW MARKINGS FOR TURN LANES
100' OR LONGER.

MORE ARROWS AND ONLY'S ARE OPTIONAL
WHEN SPACE PERMITS. ARROW MARKINGS
START AT THE BEGINNING OF THE SOLID
LANE LINE.

STOP BARS ARE INSTALLED ONLY
WHERE A STOP SIGN OR TRAFFIC
SIGNAL ARE LOCATED. STOP LETTERS
ARE OPTIONAL. IF INSTALLED THEY
SHALL BE 4' FROM THE STOP BAR.

THE LONGITUDINAL SPACE
BETWEEN WORD OR SYMBOL
MESSAGE MARKINGS,
SHOULD BE AT LEAST FOUR
TIMES THE HEIGHT OF THE
CHARACTERS FOR LOW SPEED
ROADS, BUT NOT MORE THAN
TEN TIMES THE HEIGHT OF
THE CHARACTERS UNDER
ANY CONDITIONS.

EXCLUSIVE TURN LANES (LEFT OR RIGHT),
LANE LINES SHALL BE SOLID AND EXTEND
BACK FROM THE STOP LINE TO THE POINT
OF FULL LANE WIDTH OF THE TURN LANE.
3' DOTS WITH A 9' SPACE SHOULD BE
EXTENDED THE FULL LENGTH OF THE LANE
TAPER.

TYPICAL MARKINGS FOR TURN LANES

NOT TO SCALE

TYPICAL PAVEMENT MARKINGS SHEET 1

PROJECT NAME: STATEWIDE
PROJECT NUMBER: IMG MARK (I12)

FILE NAME: 11k274.dgn
PROJECT LEADER: A GAMBLE
IPARM FLIE: 11k274pm1.i

PLOT DATE: 25-JAN-2012
DRAWN BY: KAS
SHEET 3 OF 29