

**ASPHALTIC PLUG-TYPE JOINT DETAIL**  
(NOT TO SCALE)

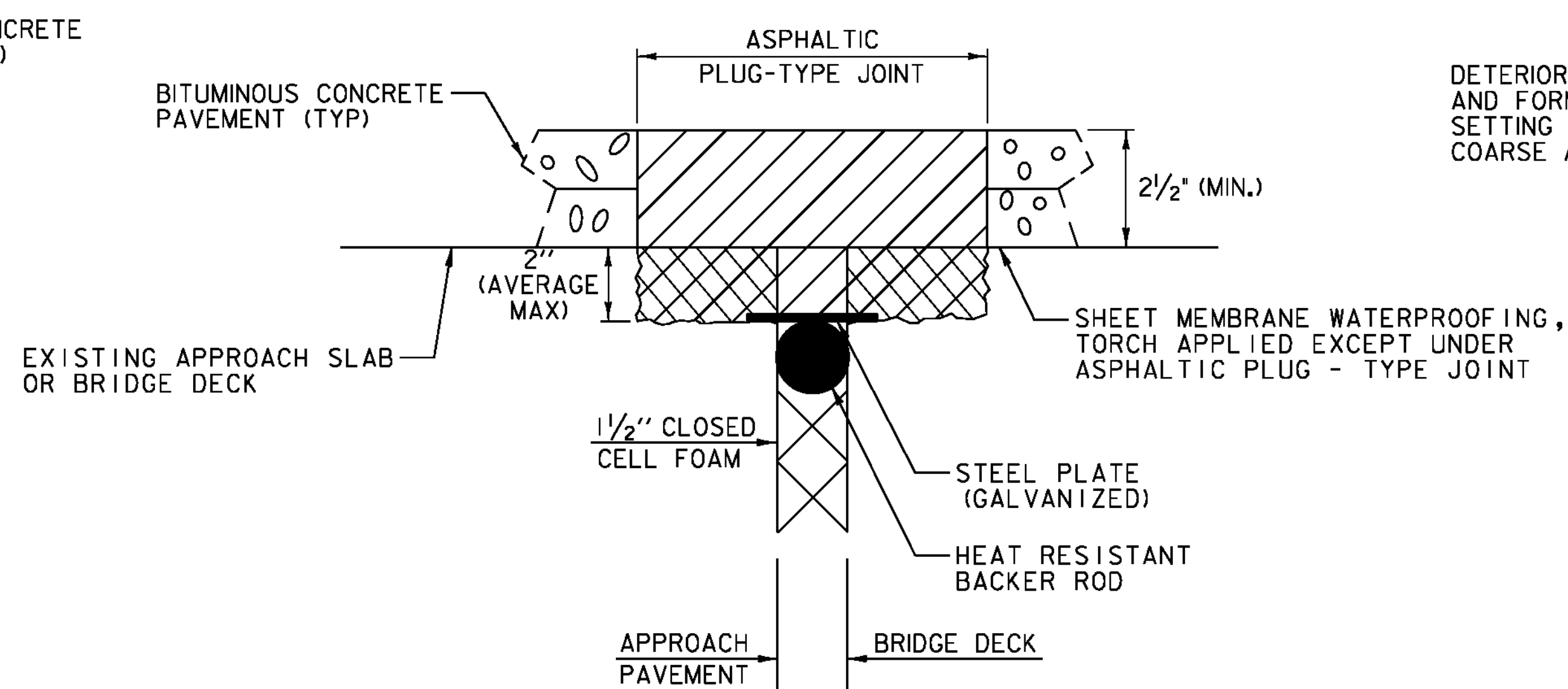

**ASPHALTIC PLUG-TYPE JOINT DETAIL**  
**REMOVAL OF UP TO**  
**2" DETERIORATED CONCRETE**  
(NOT TO SCALE)

DETERIORATED CONCRETE TO BE REMOVED AND FORMED TO EXISTING ELEV. WITH RAPID SETTING CONCRETE REPAIR MATERIAL WITH COARSE AGGREGATE (TYP). (SEE NOTES BELOW)

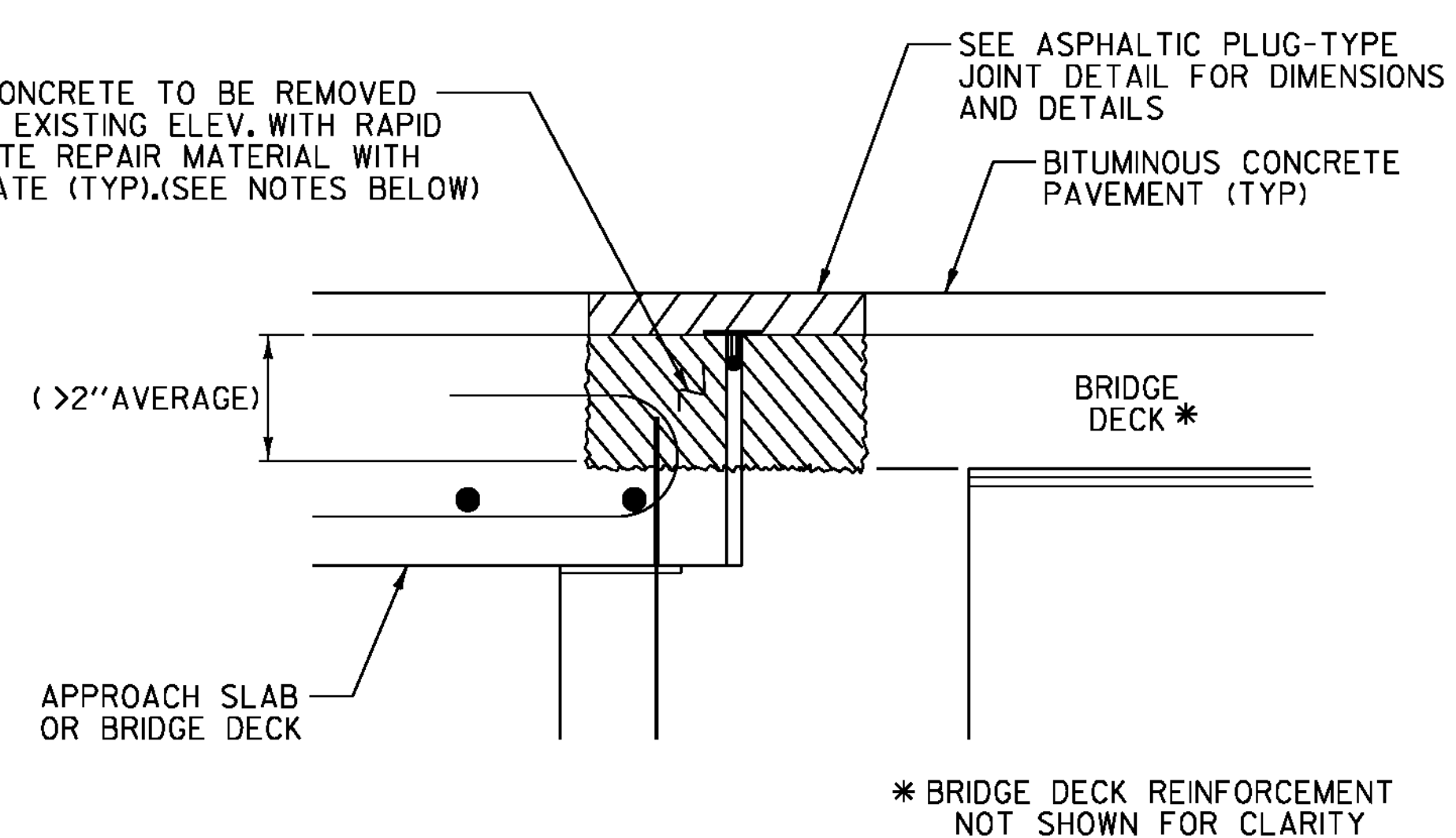

**ASPHALTIC PLUG-TYPE JOINT DETAIL**  
**REMOVAL OF >2"**  
**DETERIORATED CONCRETE**  
(NOT TO SCALE)

**NOTES:**

1. THE JOINT SHALL BE LOCATED CENTRALLY OVER THE DECK EXPANSION GAP OR FIXED JOINT MARKED OUT TO THE MANUFACTURER'S RECOMMENDED WIDTH.
2. THE JOINT SHALL BE EXCAVATED AS SHOWN ON THE PLANS BY USE OF SAWS AND PNEUMATIC HAMMER OR A HAMMER AND CHISEL.
3. THE JOINT AREA SHALL BE BLAST CLEANED OF DEBRIS AND ASPHALT. THE JOINT AREA SHALL BE THOROUGHLY DRIED USING HOT COMPRESSED AIR PRIOR TO APPLYING BINDER MATERIAL.
4. SPALLED AND DEFECTIVE CONCRETE SHALL BE REPAIRED WITH AN APPROVED MATERIAL AS AGREED UPON BY THE ENGINEER.
5. PROPERLY SIZED HEAT RESISTANT BACKER ROD SHALL BE PLACED IN THE MOVEMENT GAP ALLOWING FOR 1 INCH +/- OF BINDER ABOVE THE ROD.
6. THE BINDER MATERIAL SHALL BE HEATED AND PLACED AS RECOMMENDED BY THE MANUFACTURER.
7. PLACE 1/4 INCH THICK BY 8 INCH WIDE SECTIONS OF STEEL PLATE OVER THE CENTER OF THE MOVEMENT GAP. SECURE PLATES FROM MOVING BY INSERTING LOCATING PINS THROUGH THE PRESTAMPED HOLES INTO BACKER ROD AND COVER WITH HOT BINDER.
  - A. THE STEEL PLATES MAY BE OMITTED WHERE THE APPROACH SLAB IS COVERED WITH A STONE BASE OR BITUMINOUS PAVEMENT AND VERTICAL MOVEMENT OF THE PLATES MIGHT OCCUR.
  - B. FOR ALL EXPANSION LENGTHS OVER 100 FEET, THE CONTRACTOR SHALL BE REQUIRED TO USE STEEL PLATE. ADJACENT SURFACES SHALL BE GROUND DOWN TO ENSURE FULL CONTACT WITH THE STEEL PLATE.
8. THE BINDER MATERIAL AND AGGREGATE SHALL BE HEATED AND MIXED AS RECOMMENDED BY THE MANUFACTURER.
9. THE INSTALLATION OF MATERIAL, COMPACTION, AND TOPCOATING SHALL BE AS RECOMMENDED BY THE MANUFACTURER.
10. IMMEDIATELY AFTER TOPCOATING, AN ANTI-SKID MATERIAL SHALL BE CAST OVER THE JOINT TO REDUCE THE RISK OF TRACKING.
11. JOINT SHALL BE PROTECTED FROM TRAFFIC UNTIL THE MATERIAL HAS COOLED TO 125°F ±.

**WEATHER LIMITATIONS**

BINDER MATERIAL SHALL BE APPLIED ONLY WHEN THE FOLLOWING CONDITIONS PREVAIL:

- A. THE AMBIENT AIR TEMPERATURE IS AT LEAST 50°F AND RISING.
- B. THE ROAD SURFACE IS SUFFICIENTLY DRY.
- C. WEATHER CONDITIONS OR OTHER CONDITIONS ARE FAVORABLE AND ARE EXPECTED TO REMAIN SO FOR THE PERFORMANCE OF SATISFACTORY WORK.

**NOTES:**

1. UPON ENCOUNTERING UP TO 2" AVERAGE OF DETERIORATED CONCRETE, THE CONTRACTOR SHALL REMOVE THE DETERIORATED MATERIAL AND REPLACE IT WITH THE ASPHALTIC PLUG JOINT MATERIAL AS DIRECTED BY THE ENGINEER.
2. REMOVAL OF THE DETERIORATED CONCRETE WILL NOT BE PAID SEPARATELY BUT WILL BE CONSIDERED INCIDENTAL TO THE UNIT BID PRICE FOR ITEM 516.10. THE ADDITIONAL PLUG JOINT MATERIAL BELOW THE DESIGN DEPTH REQUIRED TO REPLACE THE DETERIORATED CONCRETE WILL BE CONSIDERED INCIDENTAL TO THE UNIT BID PRICE FOR THE ITEM 516.10.
3. THE STEEL PLATE IN THE ASPHALTIC PLUG JOINT MAY BE OMITTED ONLY IF THE REPAIRED SURFACE IS SO IRREGULAR IT WILL CAUSE VERTICAL MOVEMENT AND IT IS DIRECTED BY THE ENGINEER.

**NOTES:**

1. UPON ENCOUNTERING GREATER THAN 2" AVERAGE OF DETERIORATED CONCRETE, THE CONTRACTOR SHALL REMOVE THE DETERIORATED MATERIAL AND REPLACE IT WITH RAPID SETTING CONCRETE REPAIR MATERIAL WITH COARSE AGGREGATE.
2. REMOVAL OF THE DETERIORATED CONCRETE WILL BE INCLUDED IN THE UNIT BID PRICE FOR ITEM 580.20 "RAPID SETTING CONCRETE REPAIR MATERIAL WITH COARSE AGGREGATE".
3. THE STEEL PLATE IN THE ASPHALTIC PLUG JOINT MAY BE OMITTED ONLY IF THE REPAIRED SURFACE IS SO IRREGULAR IT WILL CAUSE VERTICAL MOVEMENT AND IT IS DIRECTED BY THE ENGINEER.

\* BRIDGE DECK REINFORCEMENT NOT SHOWN FOR CLARITY

PROJECT NAME: WATERFORD	PLOT DATE: 3/19/2012
PROJECT NUMBER: IM MEMB(31)	DRAWN BY: MWS
FILE NAME: s1a296jnt_detail.dgn	CHECKED BY: JF
PROJECT LEADER: JPB	SHEET II OF 48
DESIGNED BY: SRB	
<b>PAVEMENT JOINT DETAILS</b>	