

HANGER TYPE				
TYPE	A	B	C	D
DIM A	86 3/8	89	85 3/4	90 7/8
DIM B	41 3/16	42 1/2	40 7/8	43 3/16
DIM C	6 3/4	6 3/4	6 3/4	6 3/4
DIM D	1 5/8	1 3/4	1 5/8	1 9/16
DIM E	3 1/4	3 1/2	3 1/4	3 5/8
SHIM THK X	3/16	1/4	5/8	1 1/2

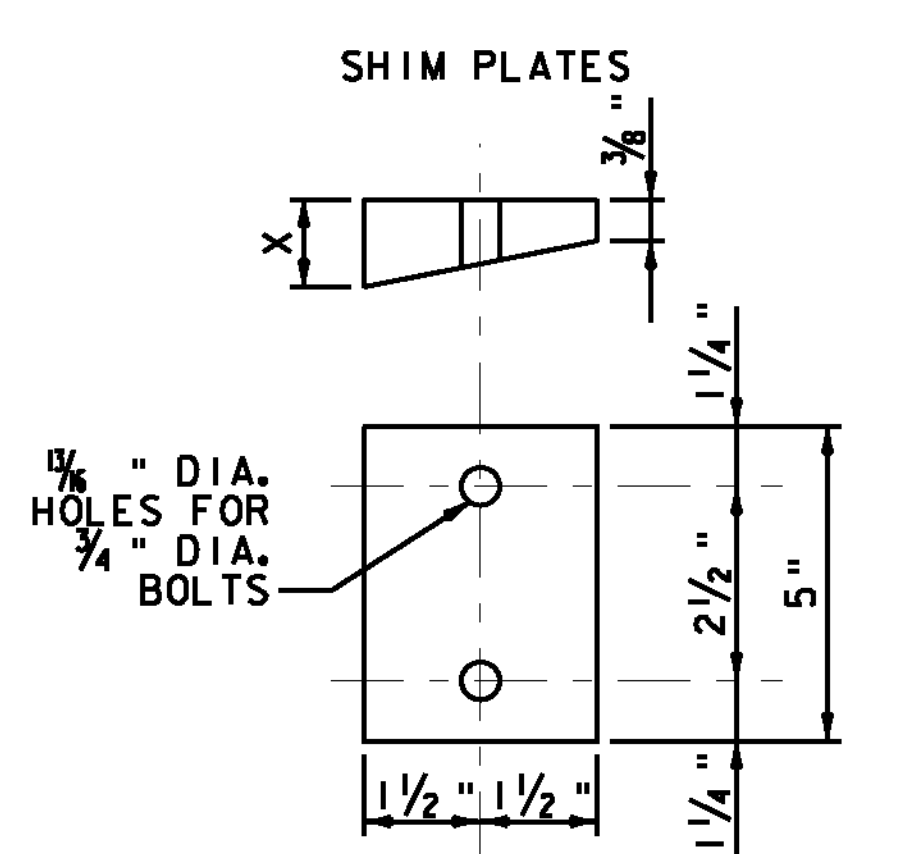

DIMENSIONS IN INCHES UNLESS OTHERWISE NOTED.

FABRICATION DETAILS - HANGER ANGLES AND TAPERED SHIM PLATES
 NOT TO SCALE

PROJECT NAME: HARTFORD SHARON
 PROJECT NUMBER: FITS503
 FILE NAME: z06e142ABUT2.dgn
 PROJECT LEADER: J. YOUNG
 DESIGNED BY: S. BOYINGTON
 BRIDGE 11N ABUTMENT 2 DETAILS
 PLOT DATE: 9/15/2010
 DRAWN BY: S. GUNN
 CHECKED BY: J. WILSON
 SHEET 47 OF 70

