

ITEMS USED ON THIS SHEET	
ITEM NO.	DESCRIPTION
501.34	CONCRETE, HIGH PERFORMANCE CLASS B
504.10	FURNISHING EQUIPMENT FOR DRIVING PILES
505.19	STEEL PILING, HP 14x102
505.45	DYNAMIC PILE LOADING TEST

PILE FOUNDATION NOTES:

1. THE PILE INSTALLATION AND PILE TESTING SHALL BE PERFORMED IN ACCORDANCE WITH THE APPROVED PILE DRIVING CRITERIA SUBMITTAL, THE REQUIREMENTS OF VTRANS STANDARD SPECIFICATIONS SECTIONS 504 AND 505, AND AS AMENDED BY THESE FOUNDATION NOTES.
2. AT ABUTMENT 1 AND ASSOCIATED WINGWALL FOUNDATION AREAS, EXCAVATION SHALL BE PERFORMED TO THE PROPOSED BOTTOM OF EXCAVATION AS SHOWN ON THE PLANS. THE EXPOSED SOIL SUBGRADE SHALL BE PROOF ROLLED WITH AT LEAST 6 PASSES OF A DOUBLE DRUM WALK BEHIND VIBRATORY ROLLER OR LARGE VIBRATORY PLATE COMPACTOR. ANY POCKETS OF EXCESSIVELY SOFT, WET OR DISTURBED SOIL OR UNSUITABLE SOIL SHALL BE REMOVED AND REPLACED WITH PROPERLY COMPACTED 3/4" COARSE AGGREGATE FOR CONCRETE, WHICH HAS GRADATION LIMITS CONSISTENT WITH TABLE 704.02B OF THE VTRANS STANDARD SPECIFICATIONS.
3. AT THE PIER 1 AND 2 FOUNDATION AREAS, SUBGRADE ELEVATIONS ARE BELOW THE EXISTING GROUNDWATER LEVEL. THEREFORE, STEEL SHEET PILE COFFERDAMS AND DEWATERING SYSTEMS SHALL BE INSTALLED AND IN OPERATION BEFORE SUBGRADE EXCAVATION. TO MAINTAIN A STABLE SUBGRADE, DEWATER THE EXCAVATION TO AT LEAST TWO FEET BELOW THE PROPOSED BOTTOM OF EXCAVATION. SUBGRADE PROOF-COMPACTION USING NON-VIBRATORY METHODS MAY BE CONSIDERED IN THESE AREAS CONSISTENT WITH THE GEOTECHNICAL REPORT, IF REQUIRED TO LIMIT SUBGRADE DISTURBANCE.
4. SNOW OR ICE, IF EXISTING, SHALL BE COMPLETELY REMOVED PRIOR TO FOUNDATION CONCRETE PLACEMENT. FILL SHALL NOT BE PLACED OVER FROZEN SOIL. SOIL SUBGRADES SHALL BE PROTECTED AGAINST FROST BOTH DURING AND AFTER CONSTRUCTION.
5. PROPER DRAINAGE OF CONSTRUCTION AREAS SHALL BE PROVIDED TO PROTECT THE SUBGRADES FROM THE DETRIMENTAL EFFECTS OF WEATHER CONDITIONS. EXCAVATIONS SHALL BE MADE WITH AS FEW PASSES OF THE BACKHOE BUCKET AS POSSIBLE TO REDUCE DISTURBANCE OF THE SUBGRADE. THE EXPOSED BASE SHALL BE KEPT FREE OF STANDING WATER AT ALL TIMES. THE SITE SHALL BE GRADED TO CARRY ANY SURFACE RUNOFF AWAY FROM THE WORK AREAS. CONSTRUCTION TRAFFIC SHALL BE CONTROLLED TO PREVENT EXCESSIVE STRESSES AND DISTURBANCE TO THE SUBGRADE.
6. IF FOUNDATIONS ARE NOT CONSTRUCTED IMMEDIATELY AFTER GRADING, THE SUBGRADE SHALL BE SHAPED SO AS TO PREVENT PONDING. IF THE SUBGRADE IS DISTURBED, IT SHALL BE PROOF-ROLLED WITH HEAVY PLATE COMPACTOR. SOFT SPOTS OBSERVED DURING PROOF-COMPACTION OR INITIAL CONSTRUCTION SHALL BE REMOVED AND REPLACED WITH COMPACTED 3/4" COARSE AGGREGATE FOR CONCRETE.

NOTES:

1. FOR ABUTMENT 1 FOOTING REINFORCING DETAILS, SEE ABUT. 1 REINFORCEMENT - SHEET 1.
2. FOR WINGWALL 1 AND 2 REINFORCING DETAILS, SEE ABUT. 1 WINGWALL REINFORCEMENT SHEET.
3. FOR ABUTMENT 1 STEM, SEAT AND BACKWALL REINFORCING DETAILS, SEE ABUT. 1 REINFORCEMENT - SHEET 2.
4. ALL FIELD WELDING OF PILES SHALL BE PERFORMED USING STICK-TYPE ELECTRODES AND SHALL BE IN ACCORDANCE WITH ANSI/AASHTO/AWS D1.5.

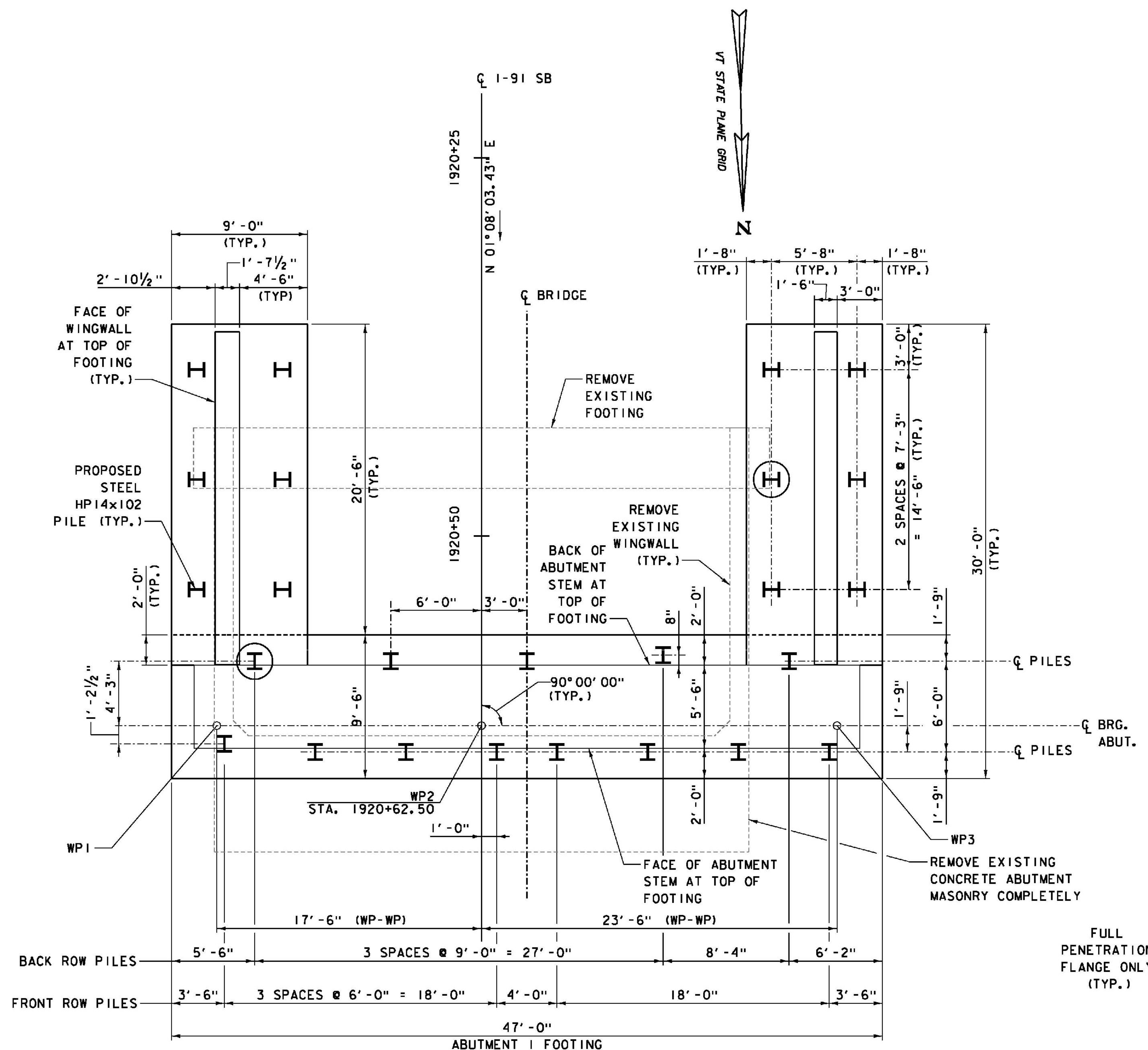

ABUTMENT 1 FOOTING PLAN

SCALE 1/4" = 1'-0"

LEGEND

INDICATES PILE DESIGNATED FOR PDA TESTING

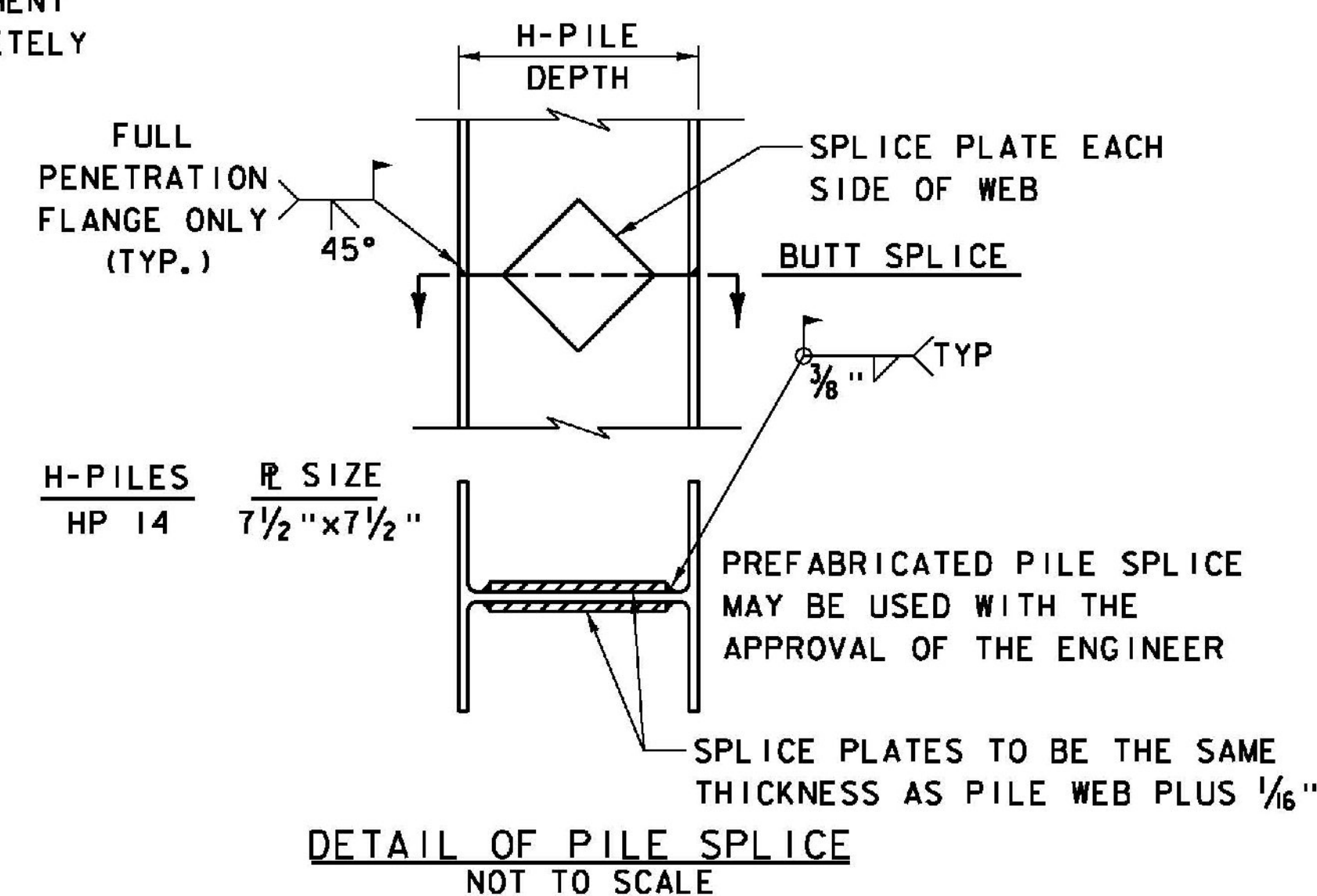

DETAIL OF PILE SPLICE
 NOT TO SCALE

PROJECT NAME: WINDSOR	PLOT DATE: 7/30/2015
PROJECT NUMBER: IM 091-1(64)	DRAWN BY: S. GUNN
FILE NAME: z10o188Abut1FP.dgn	CHECKED BY: S. HALLORAN
PROJECT LEADER: J. WILSON	SHEET 88 OF 156
DESIGNED BY: S. BOYINGTON	
ABUTMENT 1 FOOTING PLAN	