

**INTERSTATE ROUTE 91
NORTHBOUND
(MM 137.149)
BEGIN PROJECT IM SURF(25)**

**INTERSTATE ROUTE 91
NORTHBOUND
(MM 156.050)
END OF PROJECT IM SURF(25)**

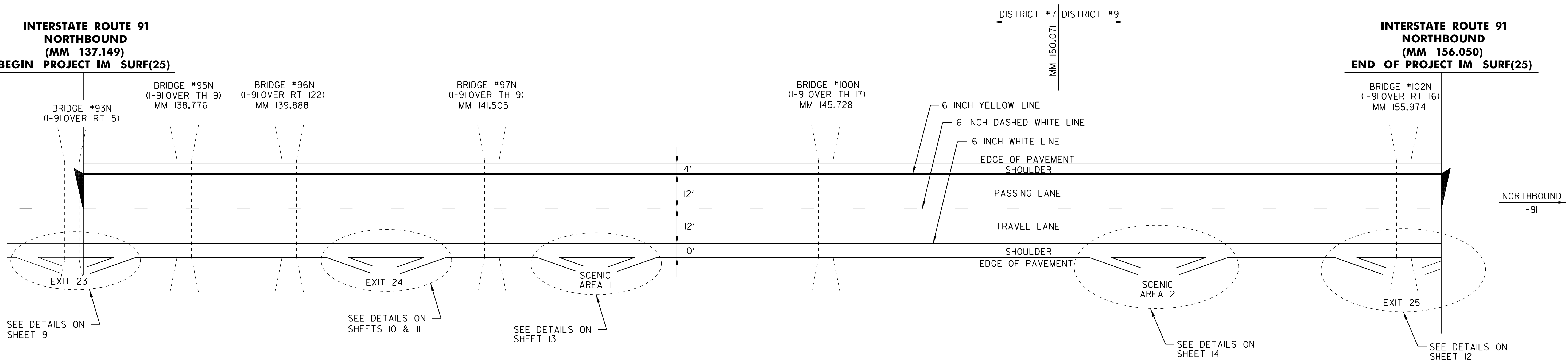

- 646.622 TEMPORARY 6" WHITE LINE, PAINT
M. M. 137.149 - M. M. 156.050 NB (SOLID RT)
M. M. 137.149 - M. M. 156.050 NB (DASH)
- 646.632 TEMPORARY 6" YELLOW LINE, PAINT
M. M. 137.149 - M. M. 156.050 NB (SOLID LT)
- 646.214 6 INCH WHITE LINE
M. M. 137.149 - M. M. 156.050 NB (SOLID RT)
M. M. 137.149 - M. M. 156.050 NB (DASH)
- 646.215 6 INCH YELLOW LINE
M. M. 137.149 - M. M. 156.050 NB (SOLID LT)

NOTES:

1. TWO (2) APPLICATIONS OF FINAL PAVEMENT MARKINGS WILL BE REQUIRED. THE FIRST APPLICATION WILL BE IMMEDIATELY FOLLOWING PLACEMENT OF THE SURFACE TREATMENT. THE SECOND AND FINAL APPLICATION WILL BE APPLIED NO SOONER THAN 14 CALENDER DAYS AFTER THE FIRST APPLICATION, AND NO LATER THAN OCT.14, 2011.

PAVEMENT MARKING DETAIL SHEET MAINLINE	PROJECT NAME:	LYNDON - BARTON
	PROJECT NUMBER:	IM SURF (25)
	FILE NAME: p10a120.dgn	PLOT DATE: 11-JUN-2012 11:44
	PROJECT LEADER: M. FOWLER	DRAWN BY: LOCKE
	DESIGNED BY: LOCKE	CHECKED BY: PAVT MGMT
	IPARM FILE NAME: p10a120pmd1.i	SHEET 8 OF 18