

# TYPICAL PAVEMENT MARKINGS

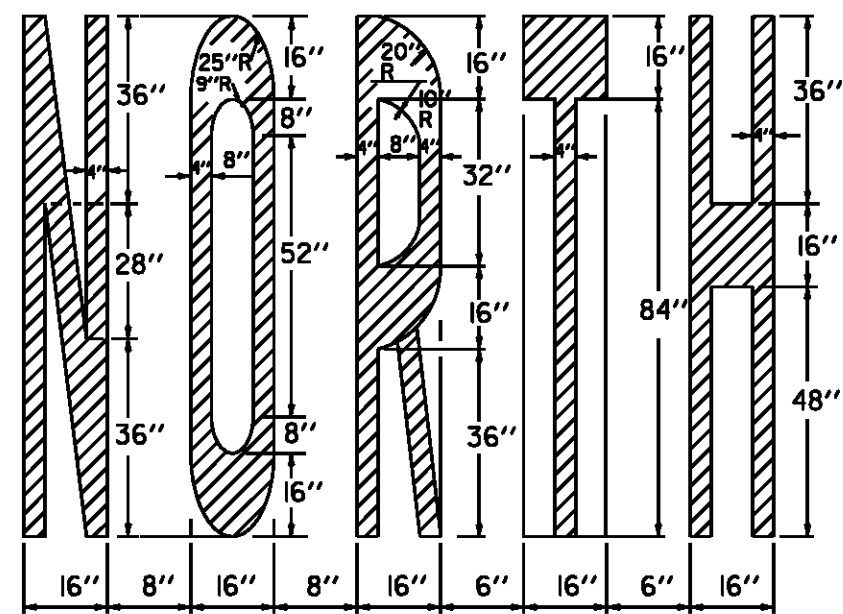

ADJUST TO AVAILABLE PAVEMENT WIDTH

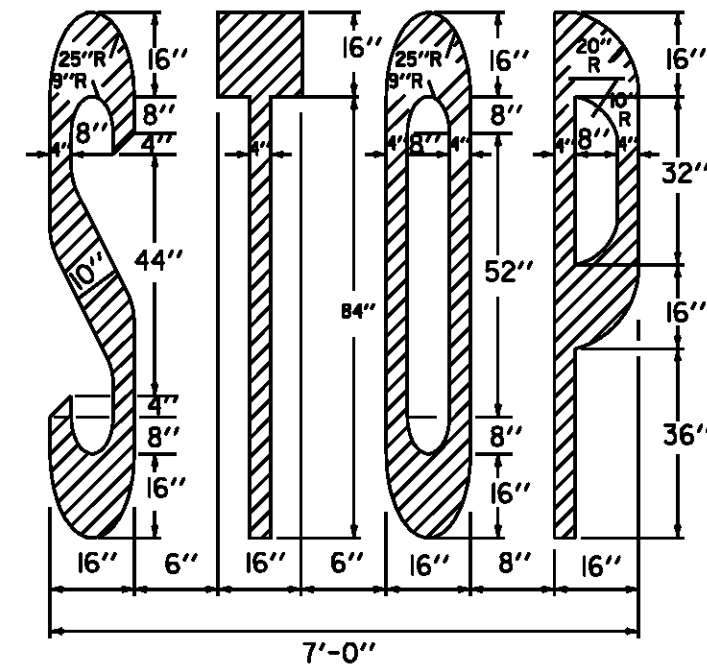

7'-0"

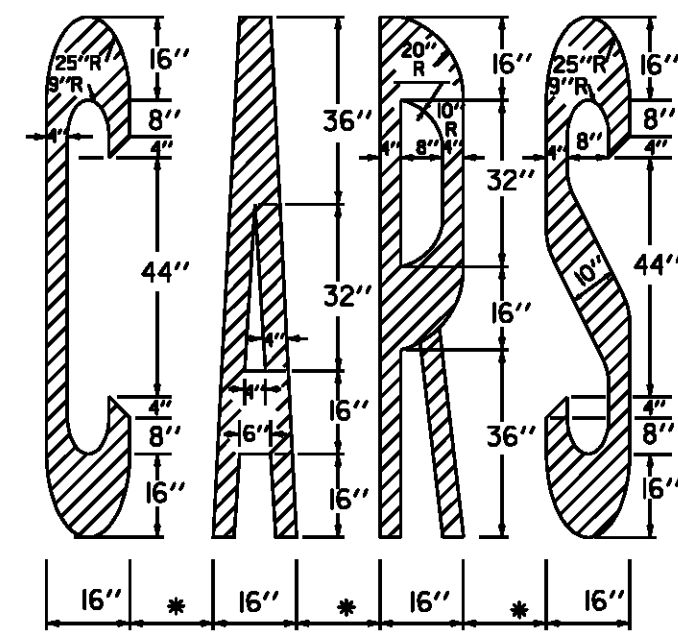

(\* 6'') - ADJUST TO AVAILABLE PAVEMENT WIDTH

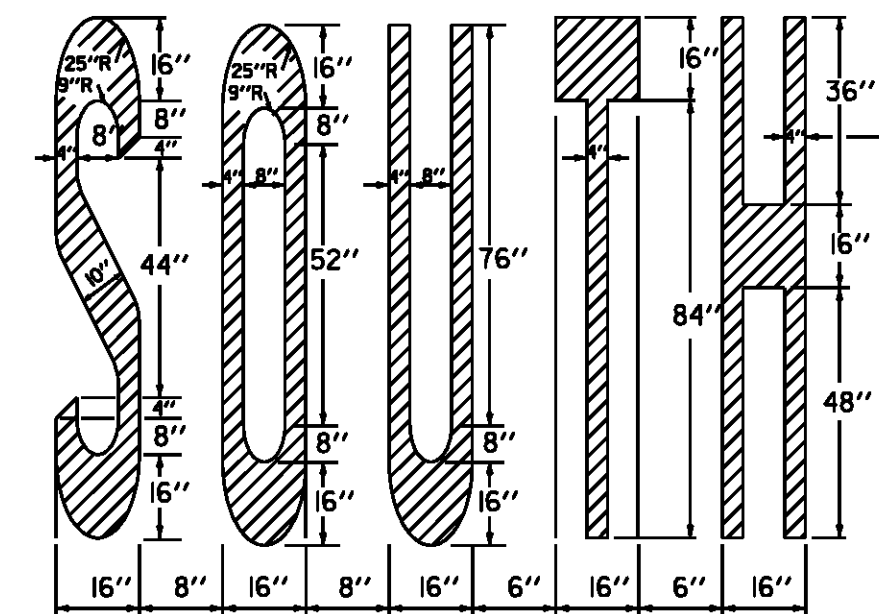
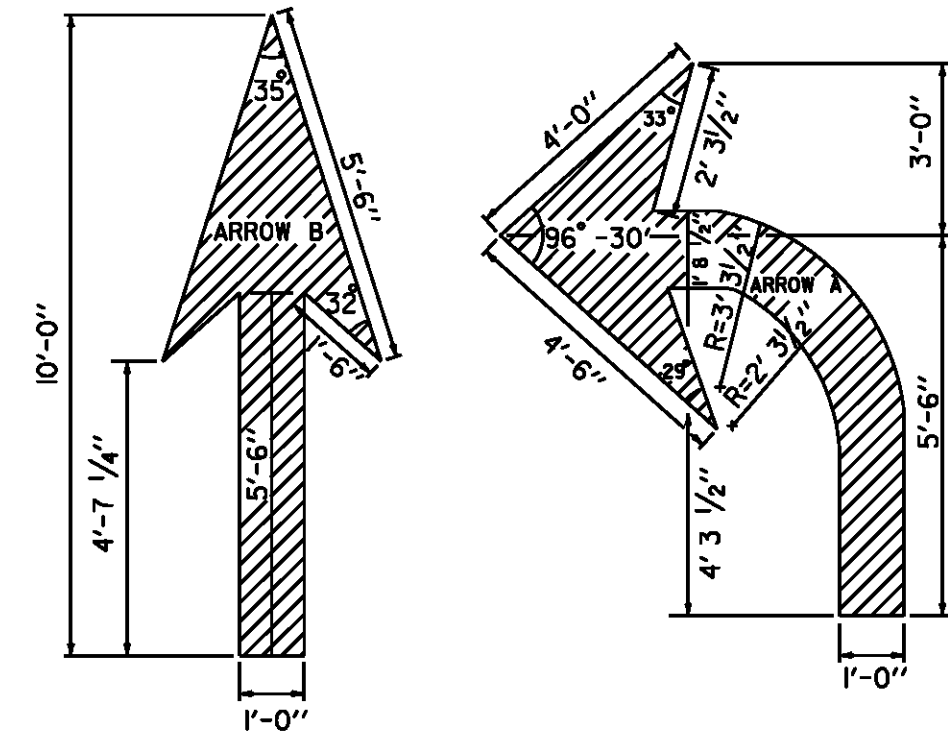

ADJUST TO AVAILABLE PAVEMENT WIDTH

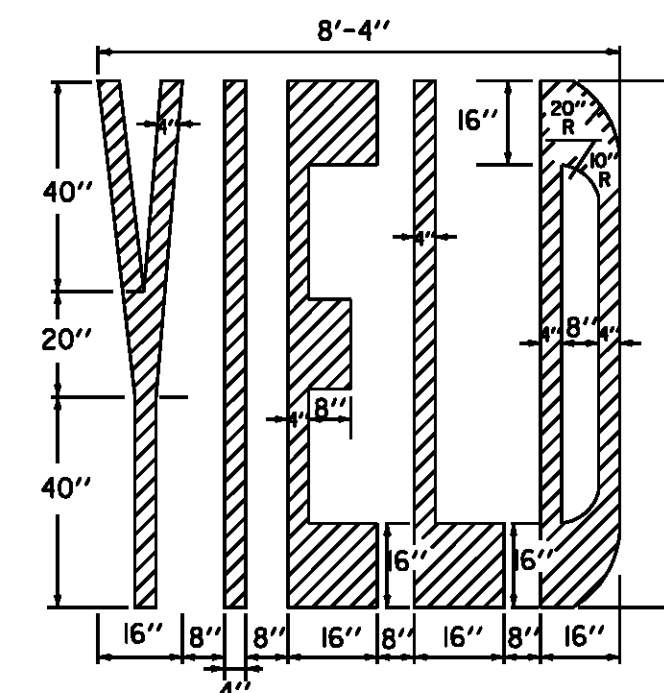

8'-4"

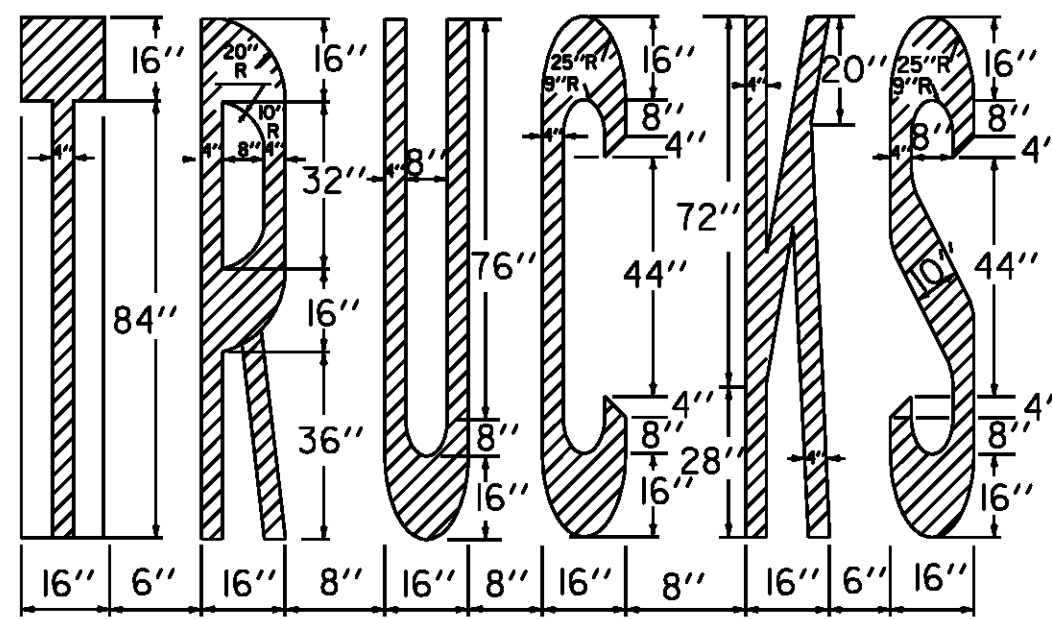

ADJUST TO AVAILABLE PAVEMENT WIDTH

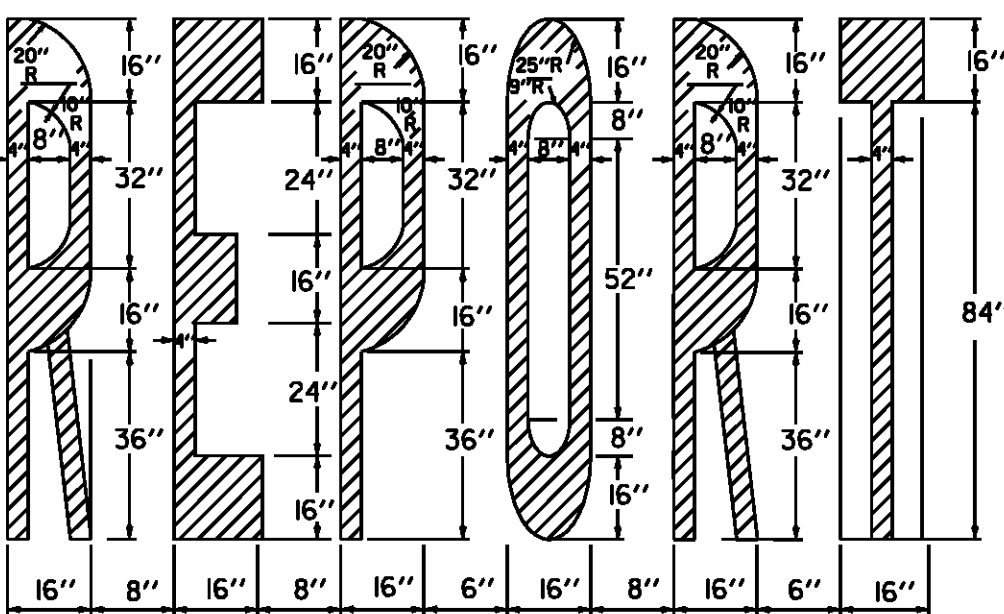
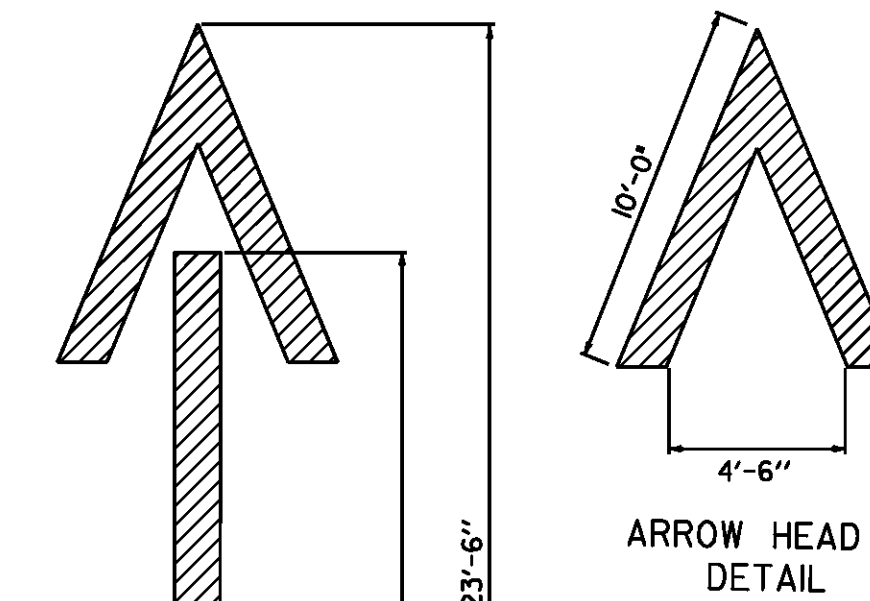

ADJUST TO AVAILABLE PAVEMENT WIDTH

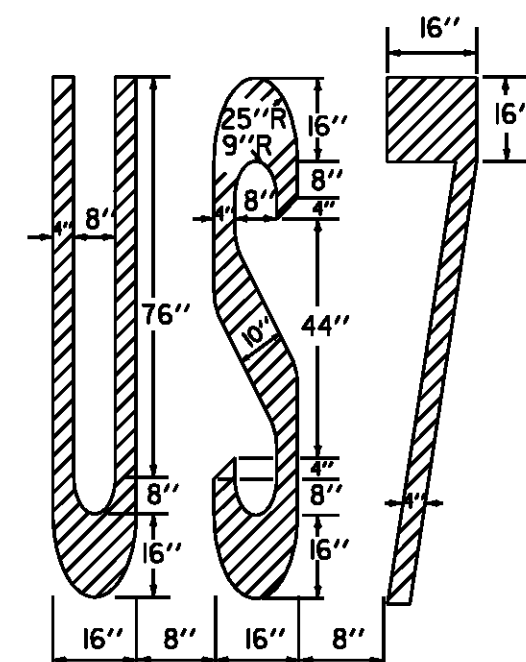
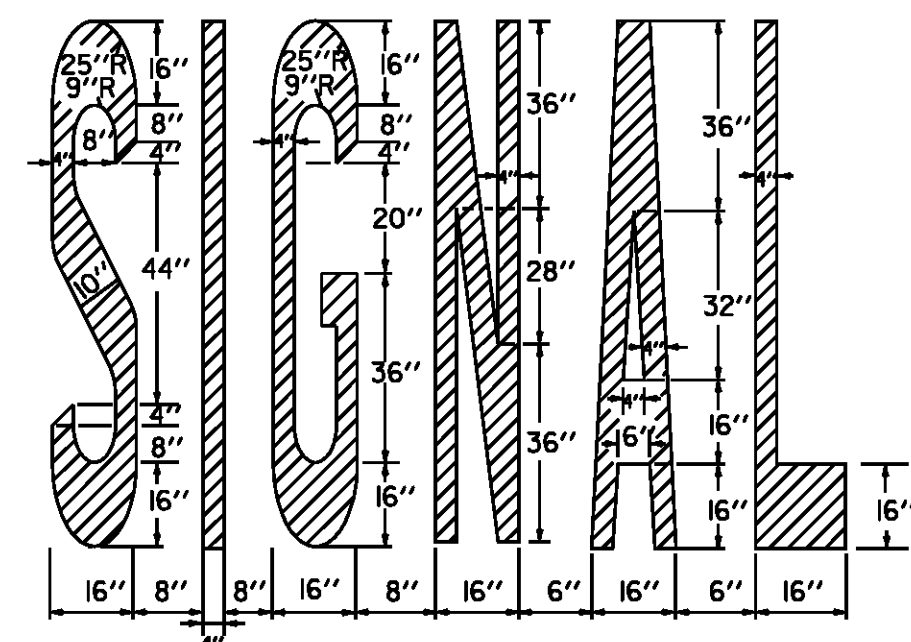

BLUE BACKGROUND  
36" X 36" FOR MINIMUM  
48" X 48" FOR STANDARD



HEIGHT OF SYMBOL  
MINIMUM 28"  
STANDARD 41"

WIDTH OF SYMBOL MINIMUM 24"  
STANDARD 36"

TO BE PAID AS TWO SYMBOLS

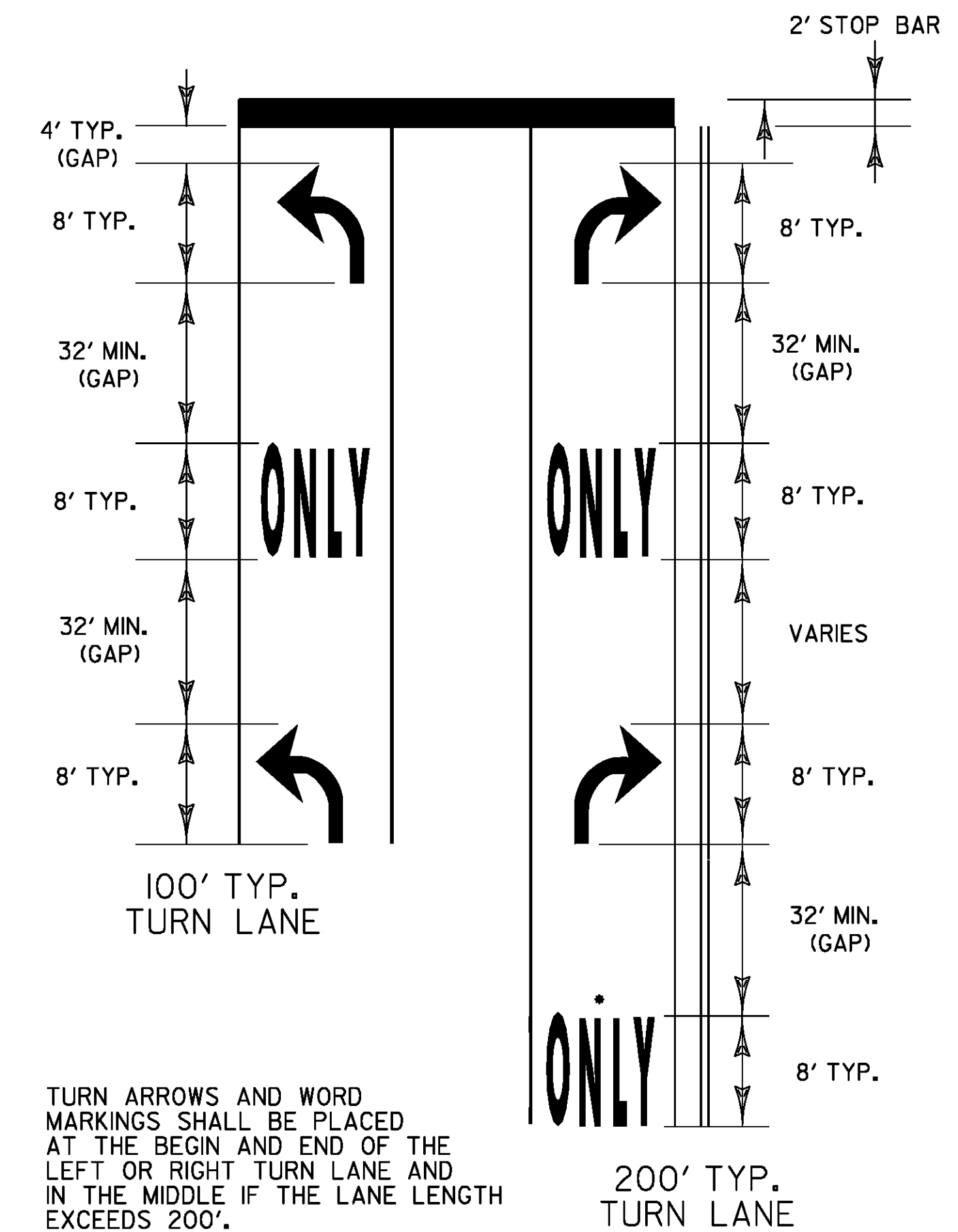

TURN ARROWS AND WORD MARKINGS SHALL BE PLACED AT THE BEGIN AND END OF THE LEFT OR RIGHT TURN LANE AND IN THE MIDDLE IF THE LANE LENGTH EXCEEDS 200'.

IF LANE LENGTH IS LESS THAN 50 FEET, ONLY ONE TURN ARROW PLACED AT THE BEGINNING OF THE SOLID LANE LINE, IS REQUIRED.

THE 'ONLY' WORD MARKINGS SHALL BE USED TO SUPPLEMENT LANE-USE ARROW MARKINGS

THE LONGITUDINAL SPACE BETWEEN WORD OR SYMBOL MESSAGE MARKINGS, SHOULD BE AT LEAST FOUR TIMES THE HEIGHT OF THE CHARACTERS FOR LOW SPEED ROADS, BUT NOT MORE THAN TEN TIMES THE HEIGHT OF THE CHARACTERS UNDER ANY CONDITIONS.

STOP BARS ARE INSTALLED ONLY WHERE A STOP SIGN OR TRAFFIC SIGNAL ARE LOCATED.

\* A SECOND 'ONLY' IS OPTIONAL WHEN SPACE PERMITS. MARKINGS START AT THE BEGINNING OF THE SOLID LANE LINE.

EXCLUSIVE TURN LANES (LEFT OR RIGHT) LANE LINES SHALL BE SOLID AND EXTEND BACK FROM THE STOP LINE TO THE POINT OF FULL LANE WIDTH OF THE TURN LANE.

## TYPICAL MARKINGS FOR TURN LANES

NOT TO SCALE

TYPICAL PAVEMENT MARKINGS SHEET 1

PROJECT: STATEWIDE	PROJECT NO.: IMG MARK(110)
DESIGN FILE NAME: p09a328.dgn	PLOT DATE: 19-JAN-2010
IPARM FILE NAME: p09a328pml	SURVEY DATE:
SURVEYED BY:	DRAWN BY: KAS
SQUAD LEADER: A GAMBLE	SHEET: 3 OF 29

## PAVEMENT MARKING DETAILS

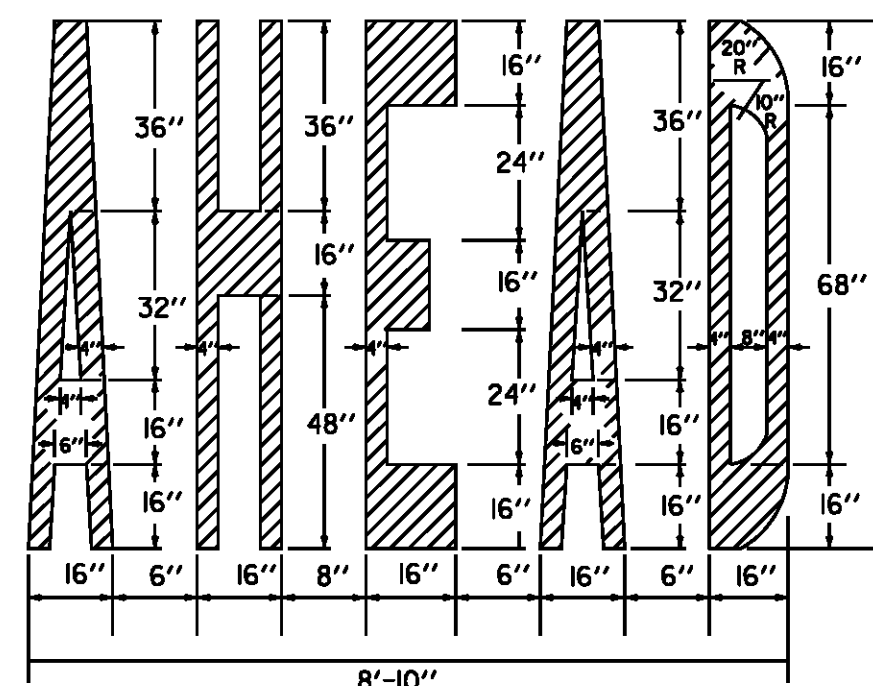
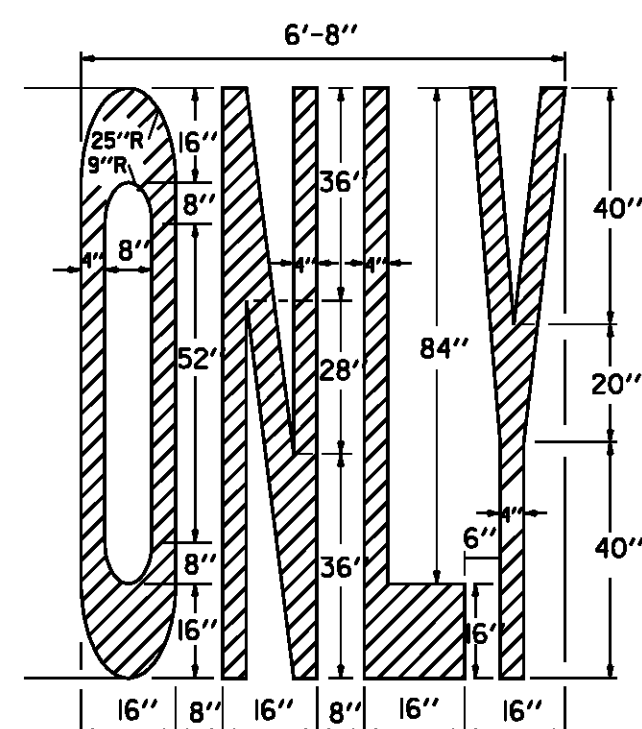

8'-10"