

# INTERSTATE TYPICAL PAVEMENT MARKINGS

NOT TO SCALE

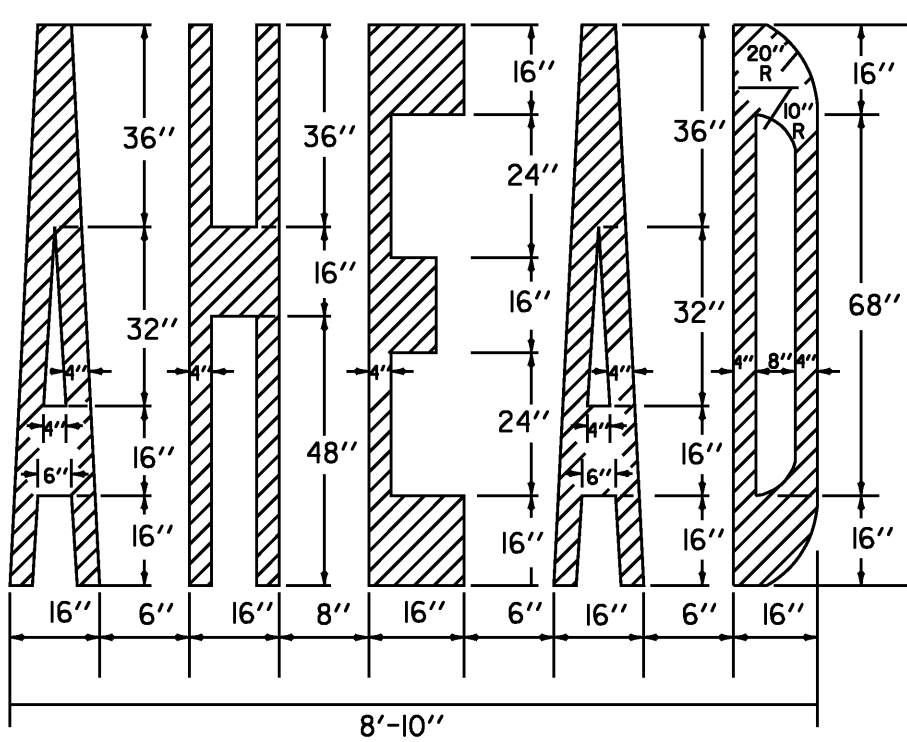

**STOP BAR DETAIL**

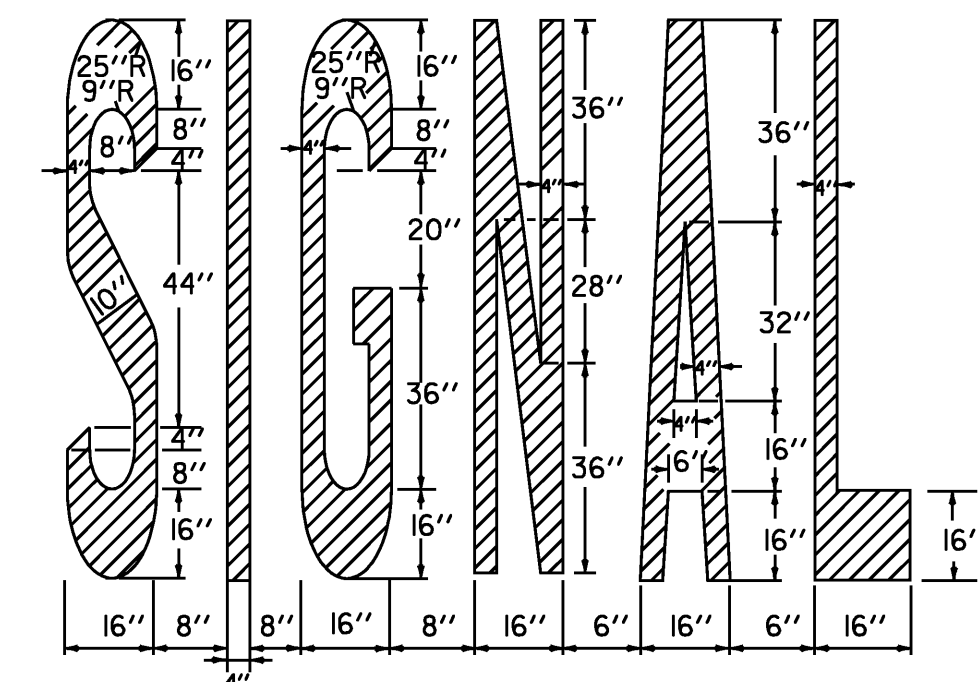
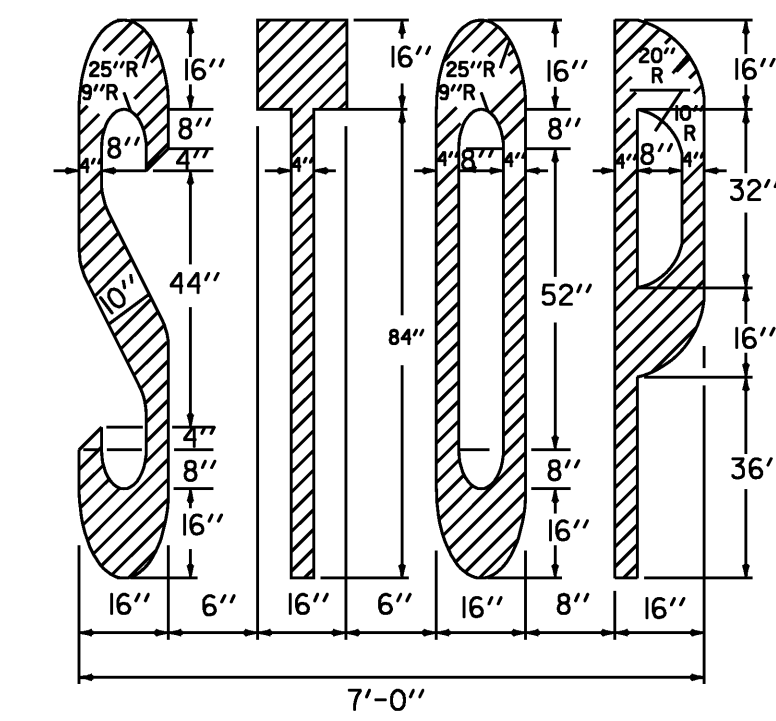
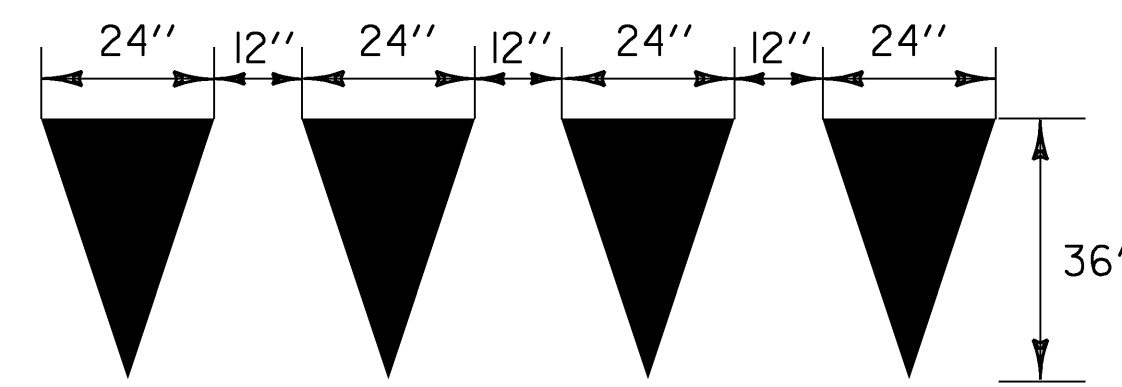
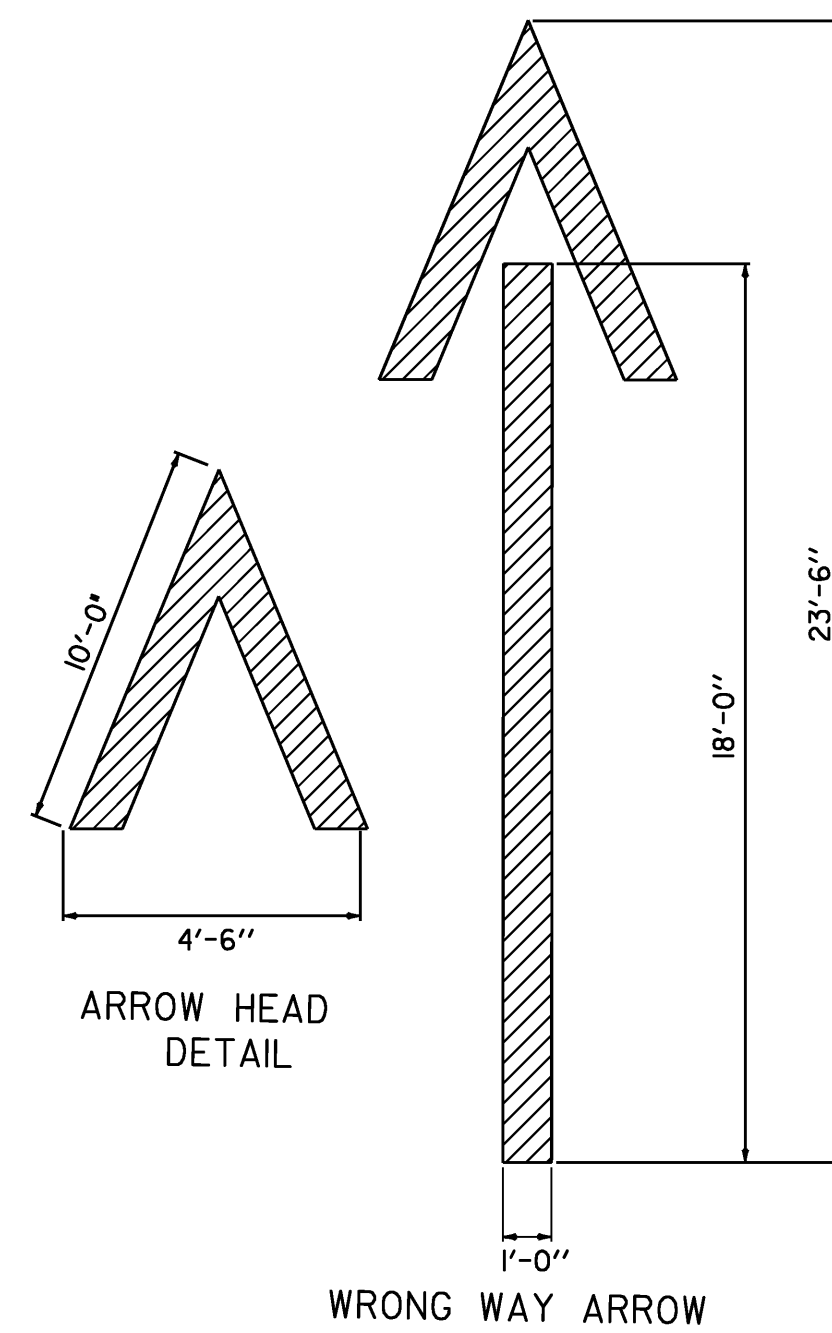

**YIELD LINE DETAILS**

TO BE INSTALLED ONLY AT THE DIRECTION OF THE RESIDENT ENGINEER TO BE PAID AS ONE LETTER OR SYMBOL PER TRIANGLE

\* TO BE INSTALLED ONLY AT THE DIRECTION OF THE RESIDENT ENGINEER

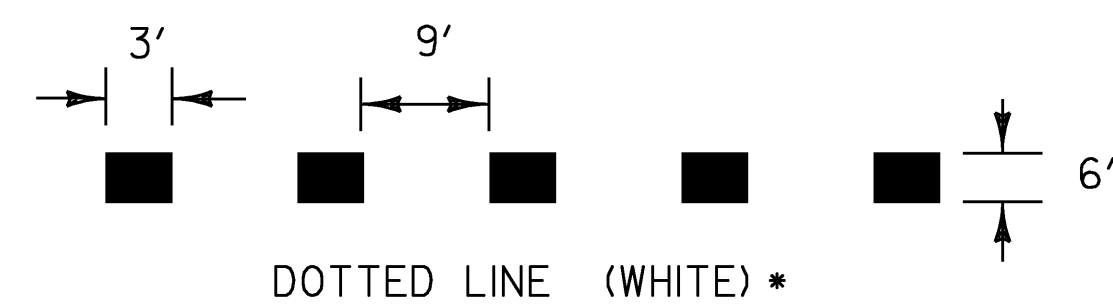

TYPICAL TWO-WAY RAMP CENTERLINE MARKING

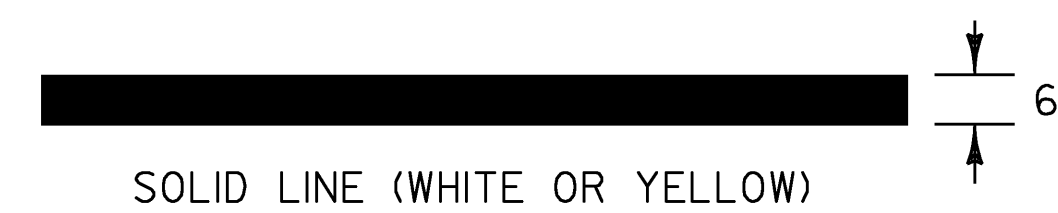

SOLID LINE (WHITE OR YELLOW)



CHANNELIZING LINE (WHITE)

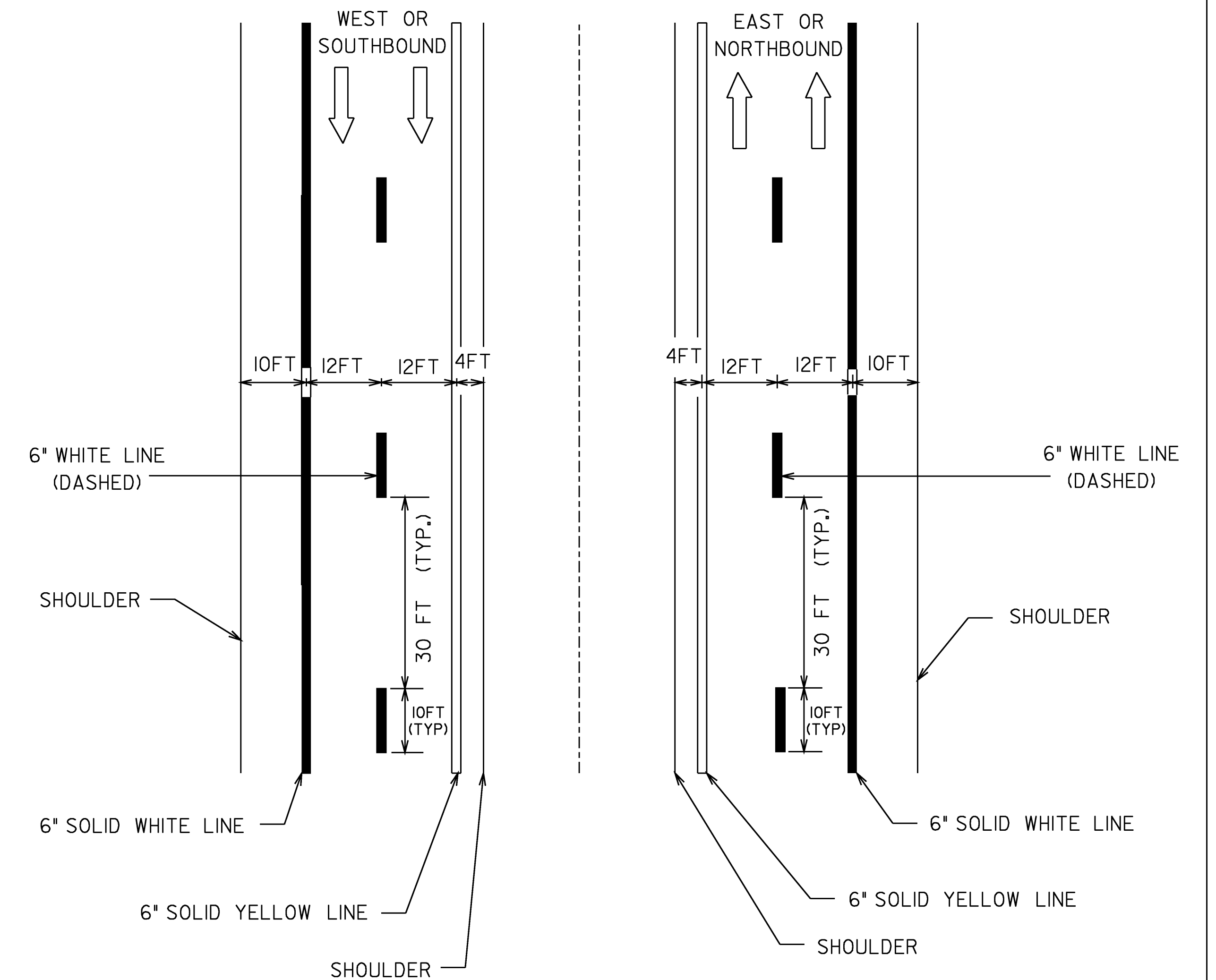

**TYPICAL MAINLINE MARKING PLAN**

**LEGEND**

- 6" WHITE LINES
- 6" YELLOW LINES
- DIRECTION OF TRAFFIC FLOW

**NOTES**

1. TWO (2) APPLICATIONS OF FINAL PAVEMENT MARKINGS WILL BE REQUIRED ON THE PAVER PLACED SURFACE TREATMENT. THE FIRST APPLICATION WILL BE IMMEDIATELY FOLLOWING PLACEMENT OF THE SURFACE TREATMENT, THE SECOND AND FINAL APPLICATION WILL BE APPLIED NO SOONER THAN 14 CALENDER DAYS AFTER THE FIRST APPLICATION AND NO LATER THAN OCTOBER 16, 2009.

**PAVEMENT MARKING LINE DETAILS**

PROJECT: <b>COLCHESTER</b>	PROJECT NO. : <b>IM SURF(12)</b>
DESIGN FILE NAME: p08a154.dgn IPARM FILE NAME: p08a154pm2.1 SURVEYED BY: SQUAD LEADER: T DOMEY	PLOT DATE: 01-JUN-2009 SURVEY DATE: DRAWN BY: KAS SHEET: 7 OF 11