

604.412 OR 604.415 REHAB. Dis, CBs OR MHS, CLASS I OR II
 STA. D2+95, RT

646.426 DURABLE 6 INCH WHITE LINE, RECESSED POLYUREA
 STA. D0+56 TO D5+17, SOLID RT (EDGE LINE)
 646.436 DURABLE 6 INCH YELLOW LINE, RECESSED POLYUREA
 STA. D0+62 TO D5+17, SOLID LT (EDGE LINE)
 646.466 DURABLE 12 INCH WHITE LINE, RECESSED POLYUREA
 RAMP D GORE - TO BE INSTALLED PER
 THE LATEST EDITION OF THE MUTCD
 STA D5+17 TO D5+33 LT

646.622 TEMPORARY 6 INCH WHITE LINE, PAINT
 STA. D0+56 TO D5+17, SOLID RT (EDGE LINE)
 646.632 TEMPORARY 6 INCH YELLOW LINE, PAINT
 STA. D0+62 TO D5+17, SOLID LT (EDGE LINE)
 646.662 TEMPORARY 12 INCH WHITE LINE, PAINT
 RAMP D GORE - TO BE INSTALLED PER
 THE LATEST EDITION OF THE MUTCD
 STA D5+17 TO D5+33 LT

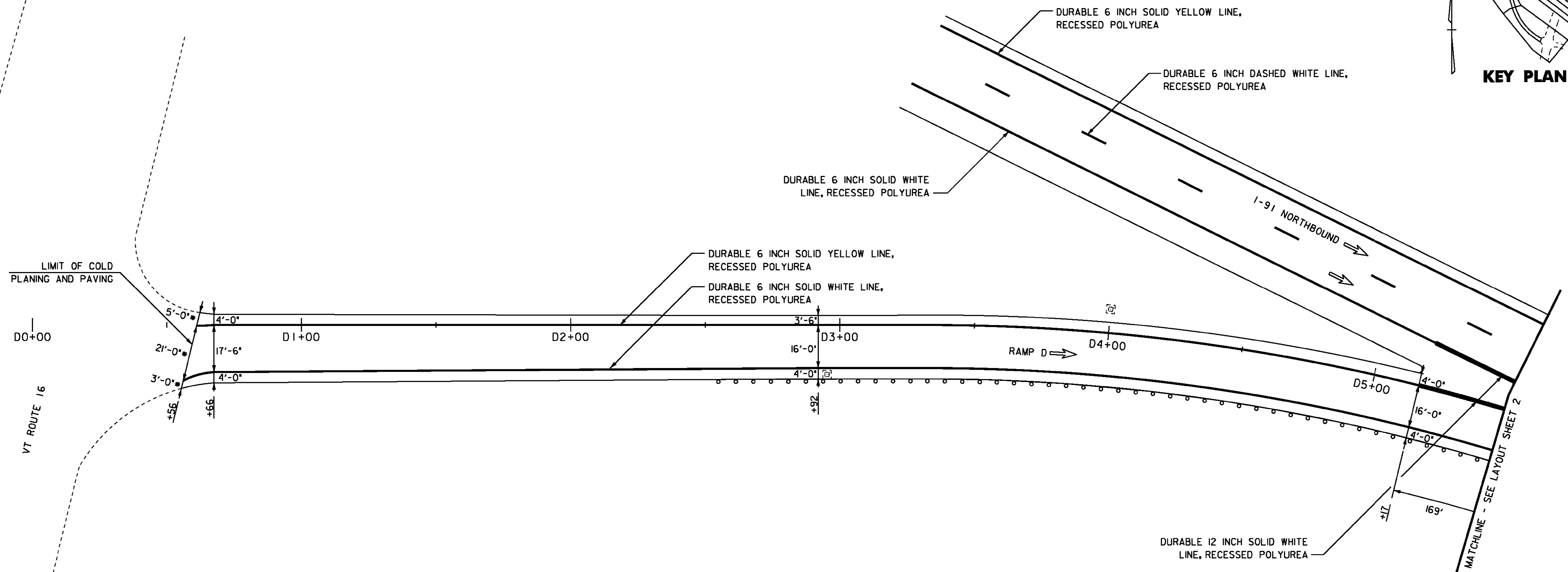
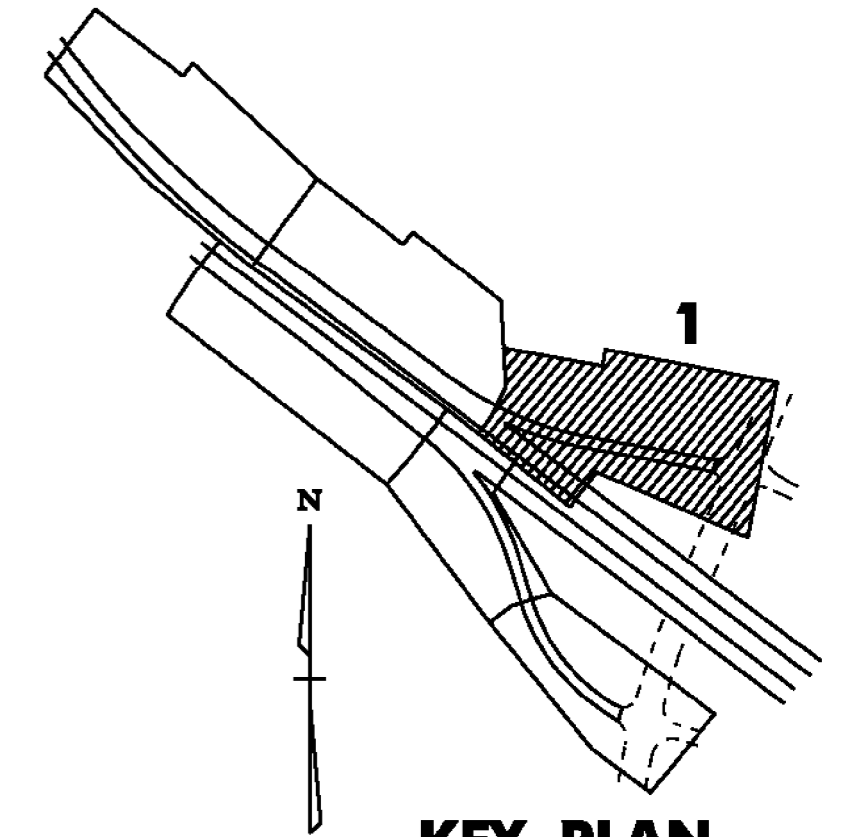

* MATCH EXISTING PAVEMENT MARKINGS

UTILITY LEGEND

	= EXISTING DI
	= EXISTING SIGN POST
	= EXISTING GUARDRAIL
	= EXISTING CULVERT

SIGN LEGEND

N	= NEW
R	= REMOVE
R&S	= REMOVE & SALVAGE
S	= SALVAGE SIGN
RET	= RETAIN
B-B	= BACK TO BACK

NOT TO SCALE

NOTE:
 ALL EXISTING SIGNS NOT SHOWN SHALL BE RETAINED.

INTERCHANGE 25 LAYOUT SHEET #1	PROJECT NAME: BARTON-IRASBURG	PLOT DATE: 06-JUL-2011
	PROJECT NUMBER: IM 091-3(48)	DRAWN BY: STANTEC
	FILE NAME: p07a286.dgn	CHECKED BY: STANTEC
	DESIGNED BY: STANTEC	SHEET 16 OF 40
IPARM FILE: p07a286101.i		

