

646.426 DURABLE 6 INCH WHITE LINE, RECESSED POLYUREA  
 STA. 0+00 TO 2+00, SOLID RT

646.436 DURABLE 6 INCH YELLOW LINE, RECESSED POLYUREA  
 STA. 0+00 TO 2+00, SOLID C

646.466 DURABLE 12 INCH WHITE LINE, RECESSED POLYUREA  
 RAMP A GORE - TO BE INSTALLED PER  
 THE LATEST EDITION OF THE MUTCD

646.492 DURABLE LETTER OR SYMBOL, THERMOPLASTIC  
 STA. 1+13, RT - ARROW

646.622 TEMPORARY 6 INCH WHITE LINE, PAINT  
 STA. 0+00 TO 2+00, SOLID RT

646.632 TEMPORARY 6 INCH YELLOW LINE, PAINT  
 STA. 0+00 TO 2+00, SOLID C

646.662 TEMPORARY 12 INCH WHITE LINE, PAINT  
 RAMP A GORE - TO BE INSTALLED PER  
 THE LATEST EDITION OF THE MUTCD

646.692 TEMPORARY LETTER OR SYMBOL, PAINT  
 STA. 1+13, RT - ARROW

675.50 REMOVING SIGNS  
 AS SHOWN - 2

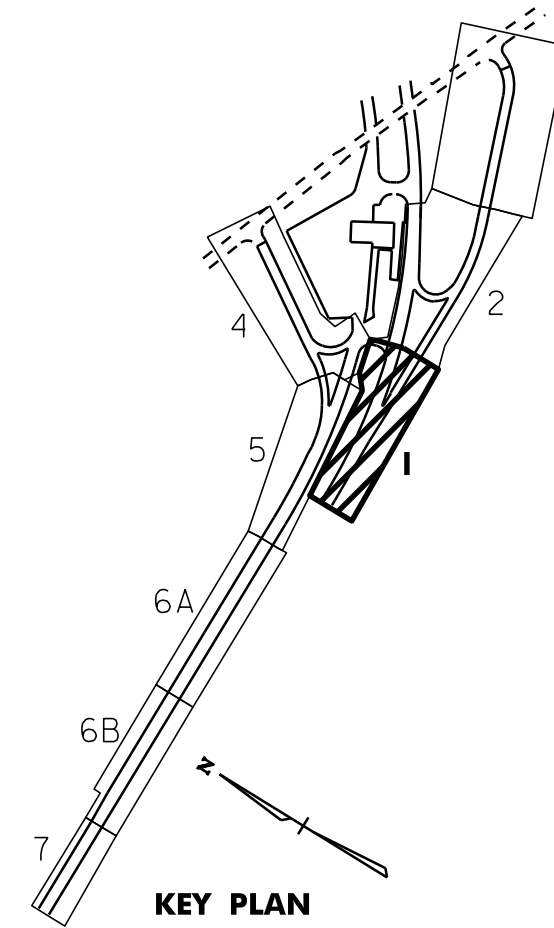
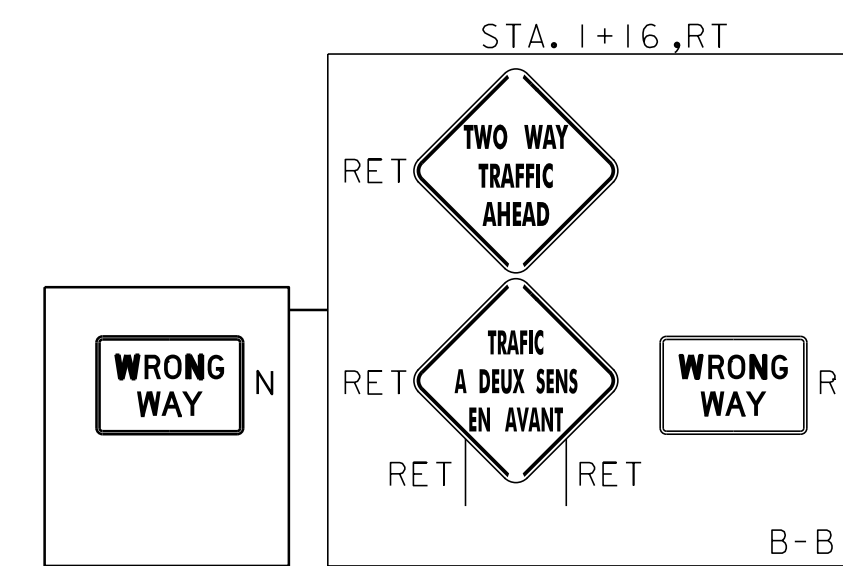
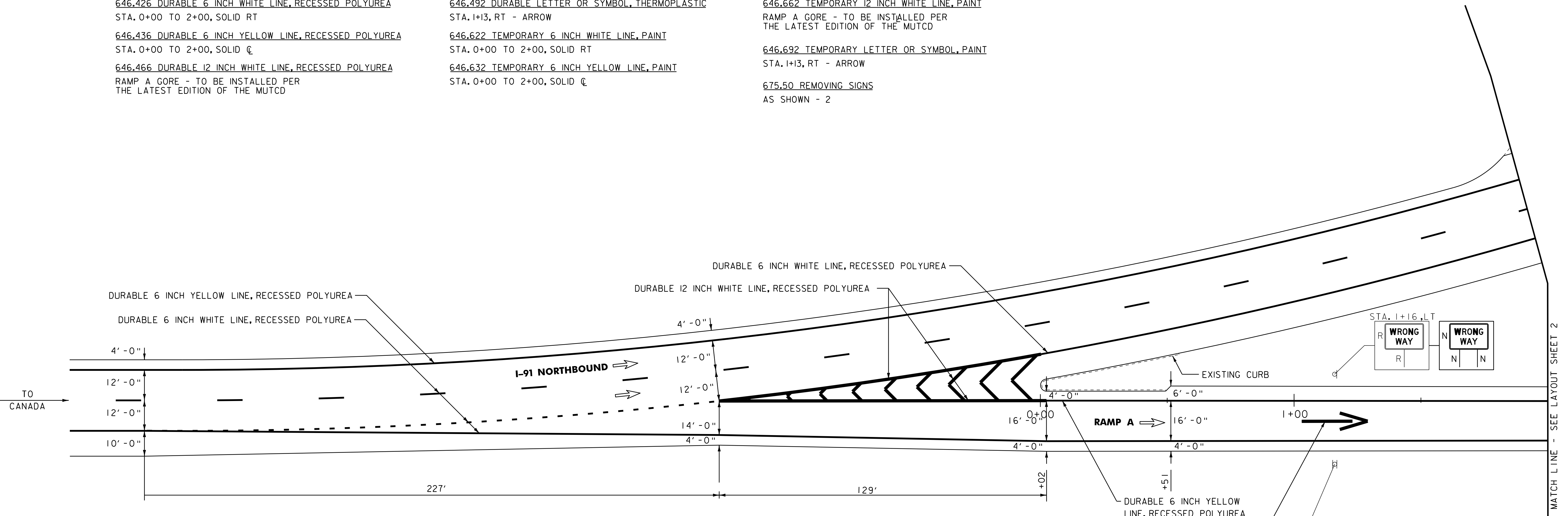

NOTES: 1. FOR STRIPING DETAILS AT GORES,  
 SEE THE PAVEMENT MARKINGS  
 DETAIL SHEET AND THE LATEST  
 EDITION OF THE MUTCD.

2. DIRECTION OF TRAVEL ARROW →



**INTERCHANGE  
 29 LAYOUT  
 SHEET #1**

NOT TO SCALE

PROJECT NAME: DERBY  
 PROJECT NUMBER: IM 091-3(46)

FILE NAME: p06a200.dgn  
 PROJECT LEADER: JLL  
 DESIGNED BY: STANTEC  
 IPARM FILE: p06a200L01.i

PLOT DATE: 07-SEP-2011 10:26  
 DRAWN BY: STANTEC  
 CHECKED BY: JLL  
 SHEET 42 OF 63