

616.47 BITUMINOUS CONCRETE GUTTERS AND TRAFFIC ISLAND
 STA. 8+65, LT
 (SEE MISCELLANEOUS DETAIL SHEET)

646.426 DURABLE 6 INCH WHITE LINE, RECESSED POLYUREA
 STA. 7+00 TO 12+50, SOLID ☐

646.622 TEMPORARY 6 INCH WHITE LINE, PAINT
 STA. 7+00 TO 12+50, SOLID ☐

646.436 DURABLE 6 INCH YELLOW LINE, RECESSED POLYUREA
 STA. 7+00 TO 12+50, SOLID LT

646.632 TEMPORARY 6 INCH YELLOW LINE, PAINT
 STA. 7+00 TO 12+50, SOLID LT

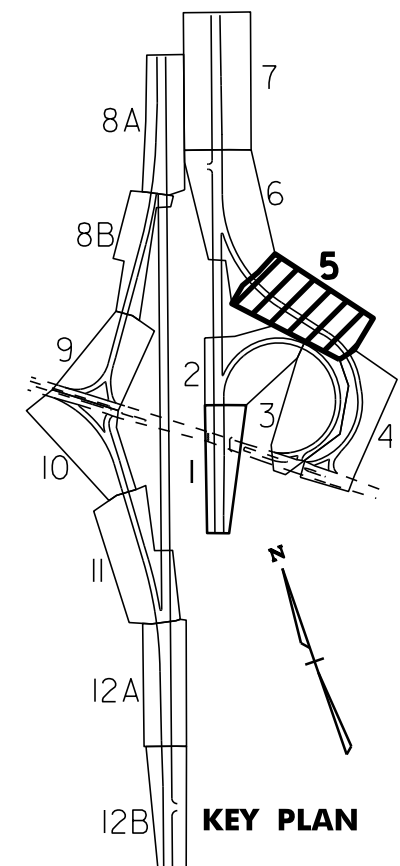
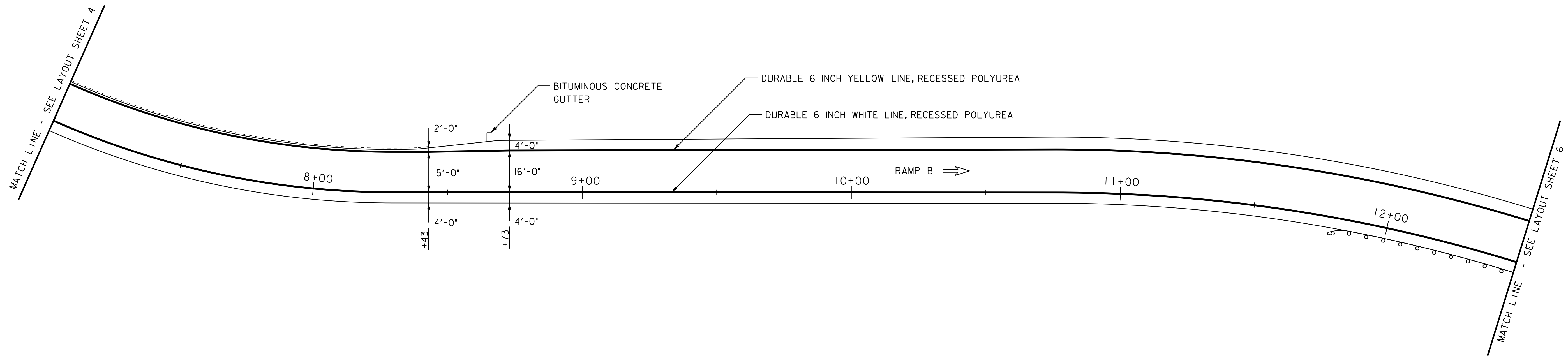

NOTES: 1. FOR STRIPING DETAILS AT GORES,
 SEE THE PAVEMENT MARKINGS
 DETAIL SHEET AND THE LATEST
 EDITION OF THE MUTCD.

2. DIRECTION OF TRAVEL ARROW ⇒



**INTERCHANGE
 27 LAYOUT
 SHEET #5**

NOT TO SCALE

PROJECT NAME: DERBY
 PROJECT NUMBER: IM 091-3(46)

FILE NAME: p06a200.dgn
 PROJECT LEADER: JLL
 DESIGNED BY: STANTEC
 IPARM FILE: p06a200i05

PLOT DATE: 07-SEP-2011 10:24
 DRAWN BY: STANTEC
 CHECKED BY: JLL
 SHEET 25 OF 63