

RIGHT SIDE OF ROADWAY

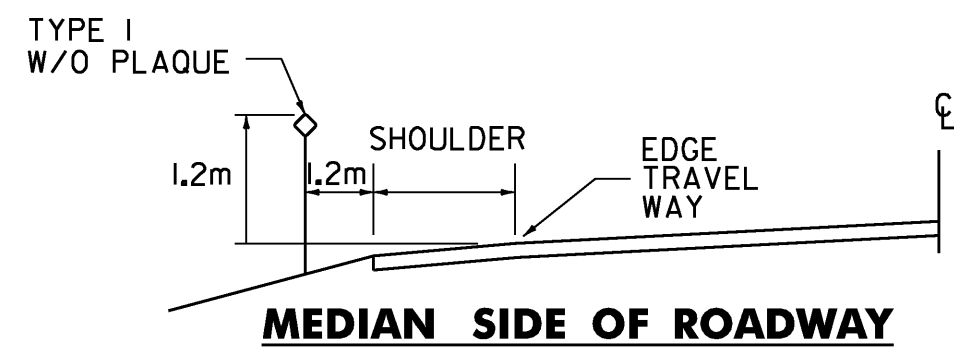

MEDIAN SIDE OF ROADWAY

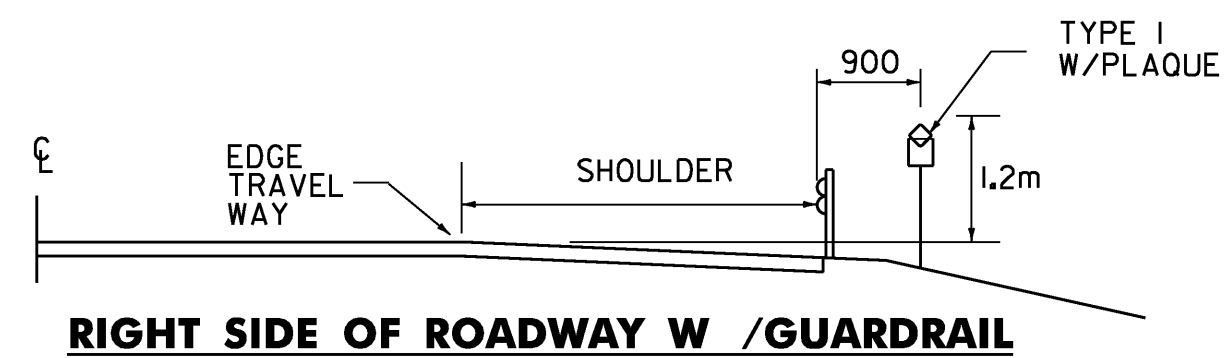

RIGHT SIDE OF ROADWAY W /GUARDRAIL

TYPICAL PLACEMENT OF TYPE I DELINEATORS AND MILEPOSTS ON DIVIDED HIGHWAY

TYPE I DELINEATORS WITH WHITE REFLECTOR UNITS AND APPROPRIATE MILEPOST PLAQUES SHALL BE ERECTED CONTINUOUSLY ALONG THE RIGHT SIDE OF DIRECTION OF TRAVEL THE DIVIDED HIGHWAYS BETWEEN MILEMARKERS.

THE TYPE I DELINEATORS WITH OR WITHOUT MILEPOST PLAQUES SHALL BE OMITTED ALONG DECELERATION AND ACCELERATION LANES, BUT THE SUCCEEDING SPACING SHALL BE AS IF THE DELINEATORS HAD BEEN ERECTED CONTINUOUSLY AND SHALL BE SO INDICATED.

THE LOCATION OF TYPE I DELINEATORS AND MILEPOSTS ARE TO BE COMPUTED AND MARKED IN THE FIELD BY THE ENGINEER IN ACCORDANCE WITH THE LATEST REVISION OF THE AGENCY'S "POLICY ON LOCATION MARKING FOR VERMONT DIVIDED HIGHWAYS."

TYPE I YELLOW DELINEATORS WITHOUT MILEPOST PLAQUES SHALL BE ERECTED CONTINUOUSLY ALONG THE LEFT OR MEDIAN SIDE OF DIVIDED HIGHWAYS, CONTINUED AT APPROXIMATELY THE SAME SPACING THROUGH INTERCHANGES AND REST AREAS WHERE THERE MAY NOT BE ANY TYPE I DELINEATORS ON THE RIGHT SIDE. PLACEMENT OF TYPE I DELINEATORS SHALL BE FOLLOWED ON THE LEFT AS ON THE RIGHT. THE SAME LATERAL TYPE I DELINEATORS WITHOUT MILEPOST PLAQUE SHALL BE INSTALLED ON INTERSTATE RAMP AS SHOWN ON THE PLANS.

TYPE I DELINEATORS USED AT U-TURNS SHALL BE PLACED WHERE THE RADI MEETS THE TANGENT OF THE MAINLINE.

TYPE III DELINEATORS

TYPE III DELINEATORS WILL BE TYPE I DELINEATORS WITH AN ADDITIONAL RED REFLECTIVE UNIT MOUNTED ON THE REVERERE SIDE, THEY SHALL BE ERECTED ON THE RIGHT AND LEFT SIDE OF THE RAMPS AS SHOWN ON THE PLANS.

TYPE III DELINEATORS SHALL BEGIN 15.2 m FROM THE WRONG WAY SIGNS AND EXTEND EVERY 15.2 m TO A POINT NOT LESS THAN 7.6 m FROM THE DIVIDED HIGHWAY. SEE STANDARD E-197.

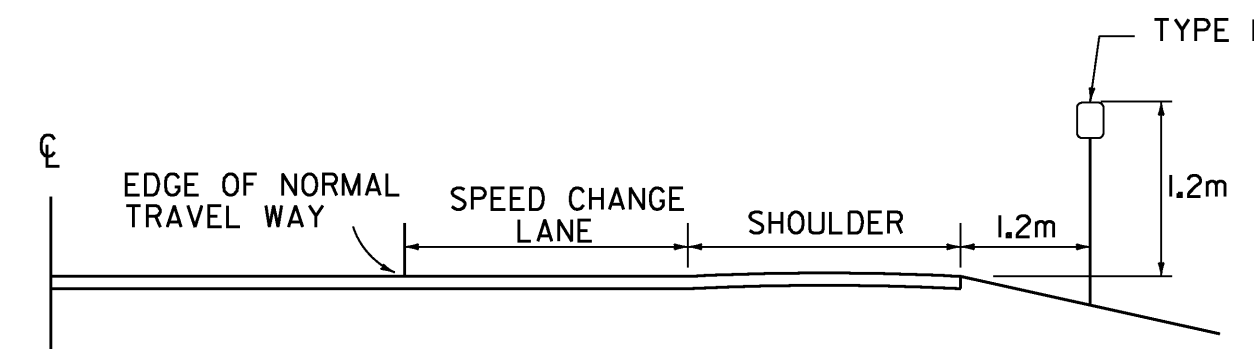

TYPICAL PLACEMENT OF TYPE II DELINEATORS ON SPEED CHANGE LANES

TYPE II DELINEATORS SHALL BE ERECTED CONTINUOUSLY ALONG THE RIGHT SIDE OF THE DECELERATION AND ACCELERATION LANES AT 30 m INTERVALS INCLUDING GUARDRAIL SECTIONS. THE DELINEATORS SHALL START AT THE BEGINNING OF THE TAPER AND END AT THE NOSE OF THE EXIT OR ENTRANCE GORE. THEY SHALL HAVE WHITE REFLECTOR UNITS.

NOTES

1. FOR MOUNTING DELINEATORS AND MILEPOSTS ON BRIDGES, SEE STANDARD E-199
2. MILEPOST PLAQUES WITH OR A WITHOUT REFLECTOR UNIT SHALL BE MOUNTED ON THE POST WITH TWO OR THREE 5 mm DIA. BY 37.5 mm LONG ALUMINUM BOLTS WITH 12.5 mm DIA. ALUMINUM VANDAL RESISTANT NUTS, OR 5 mm DIA. BY 37.5 mm LONG VANDAL RESISTANT FASTENERS.
3. DELINEATOR POSTS SHALL BE 3 kg/m FLANGE CHANNEL A MINIMUM OF 2.4 METERS LONG.
4. DELINEATOR POSTS SHALL HAVE A MINIMUM EMBEDMENT OF 750 mm IN THE GROUND.
5. WHEN USING DELINEATORS AND MILEPOSTS ON STEEP SLOPES (1 ON 2 OR STEEPER) OR ERODED SOILS ADD 300 mm FOR GREATER STABILITY.

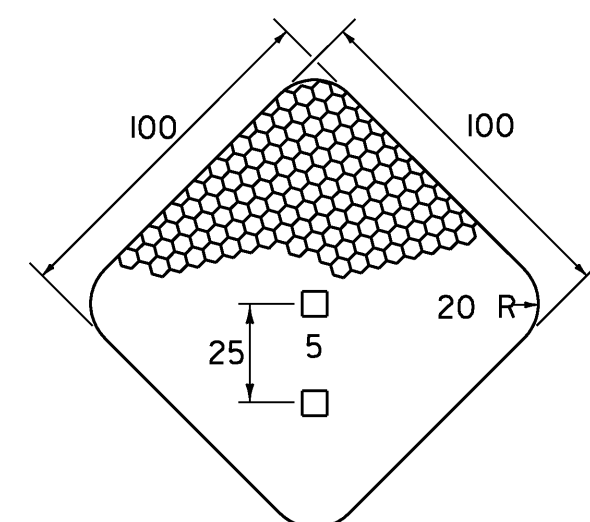

DELINEATOR REFLECTIVE SHEETING UNIT

MATERIAL FOR RETROREFLECTIVE SHEETING FOR DELINEATORS SHALL BE A 1.60-mm ALUMINUM BACKING WITH A WHITE ASTM TYPE III, OR RED/YELLOW SHALL BE TYPE VII, TYPE VIII OR TYPE IX.

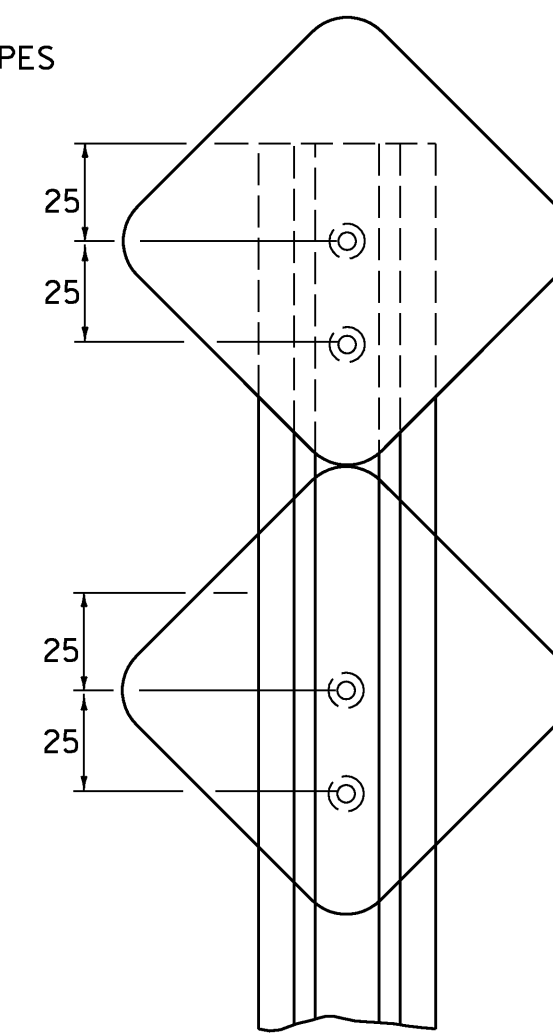

TYPE I AT U TURNS

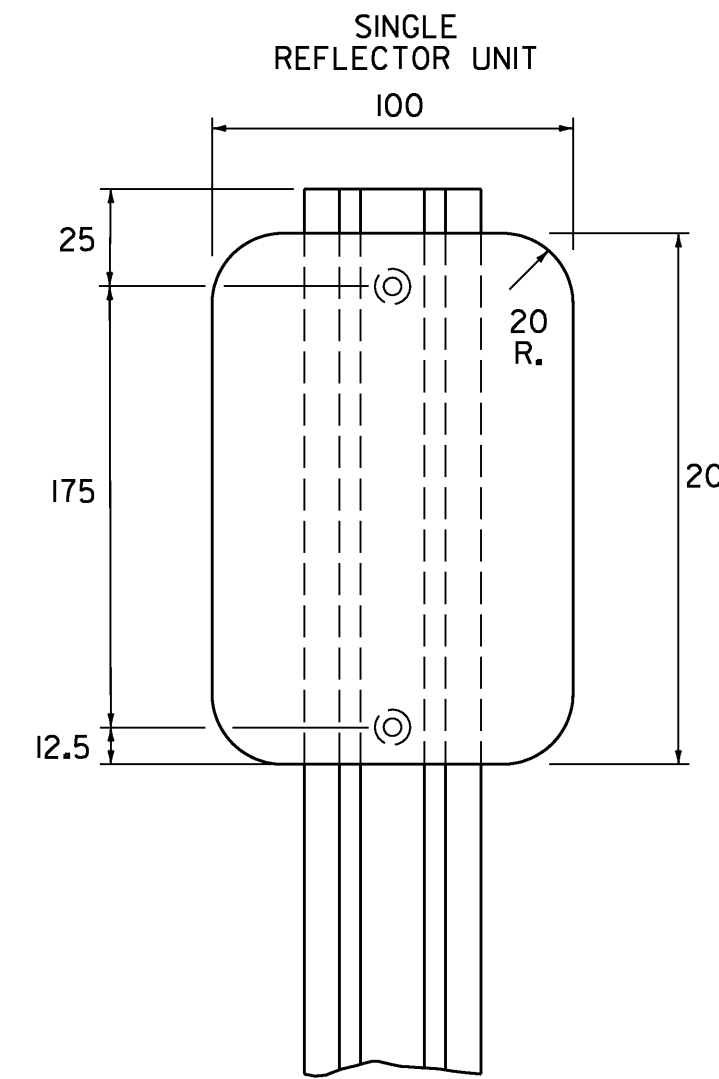

TYPE II

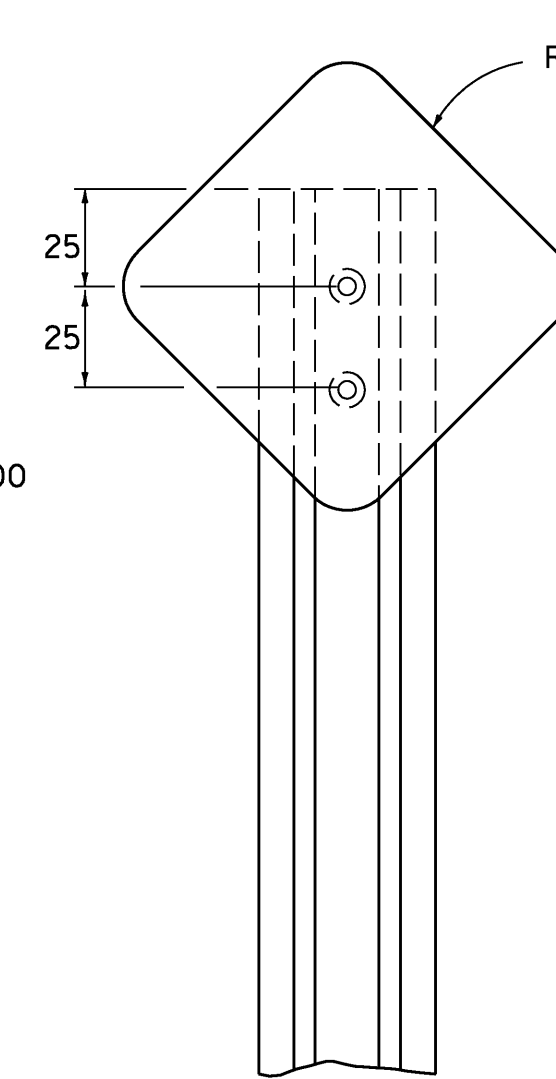

TYPE I WITHOUT PLAQUE

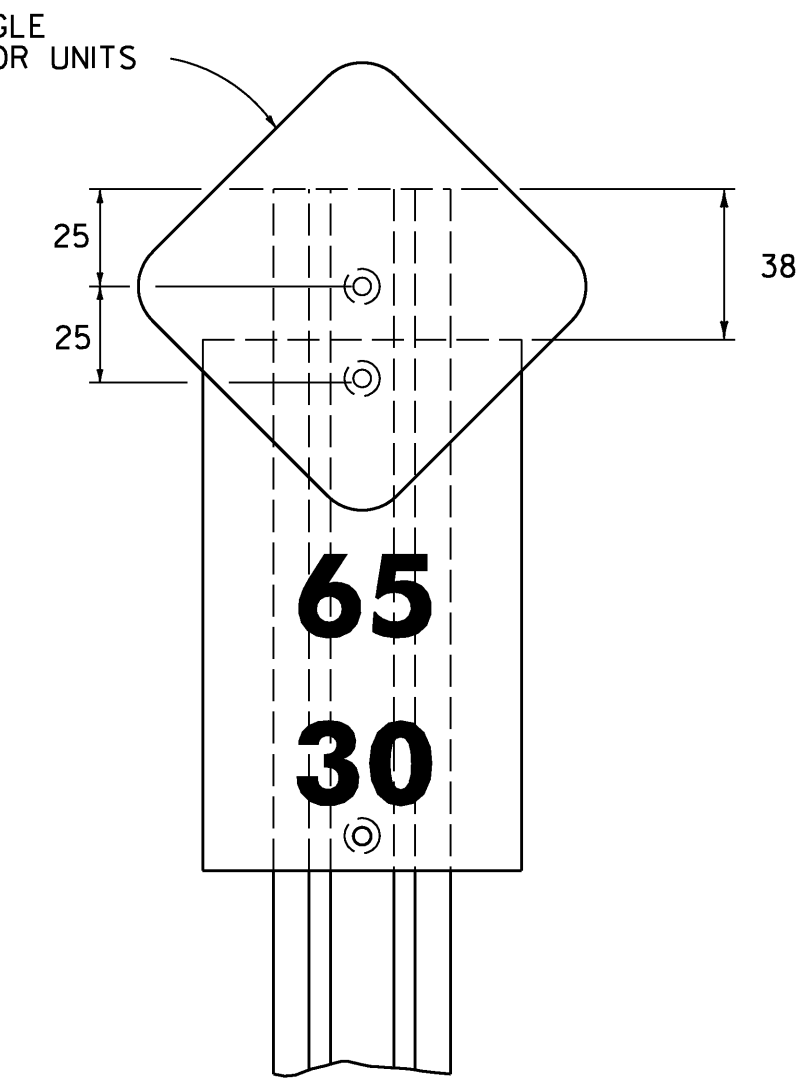

TYPE I WITH PLAQUE

DELINEATORS WITH REFLECTIVE SHEETING

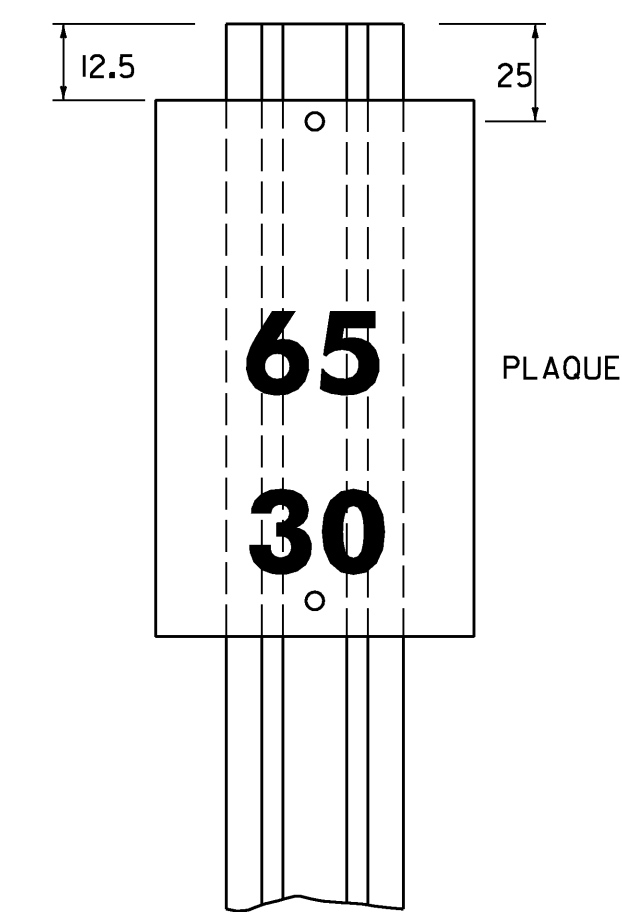
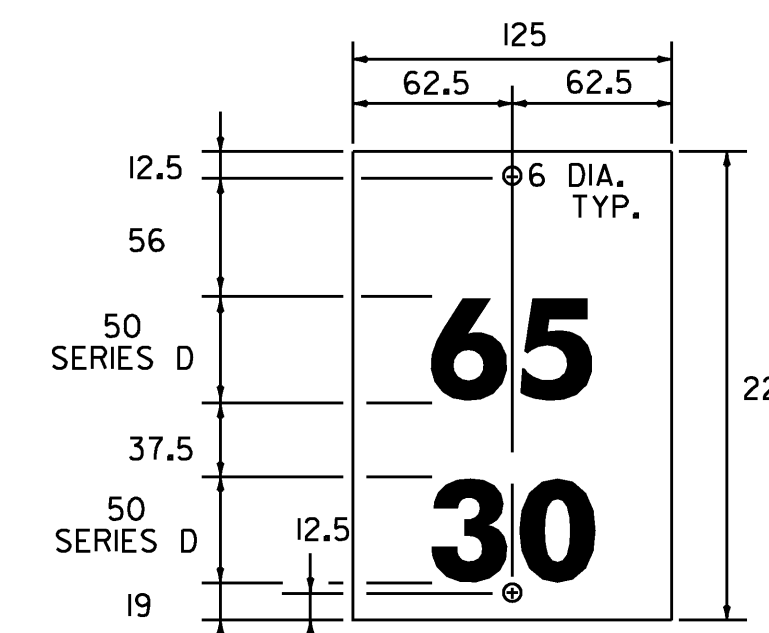
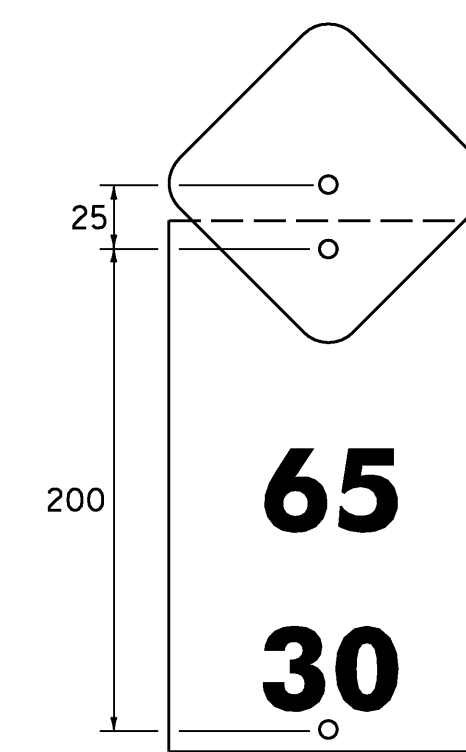

MILEPOST PLAQUE

DELINEATOR AND MILEPOST DETAILS

PROJECT NAME:	ST. JOHNSBURY-LYNDON / WATERFORD
PROJECT NUMBER:	HES 091-3(42) / HES 093-1(10)
FILE NAME:	97211s-gennotes.dgn
PROJECT LEADER:	CRB
DESIGNED BY:	DAM
CLD REF. NO.:	97-0211
PLOT DATE:	1/4/2007
DRAWN BY:	JCS
CHECKED BY:	DAM
SHEET	4 OF 130