

STORMWATER TREATMENT DETAILS

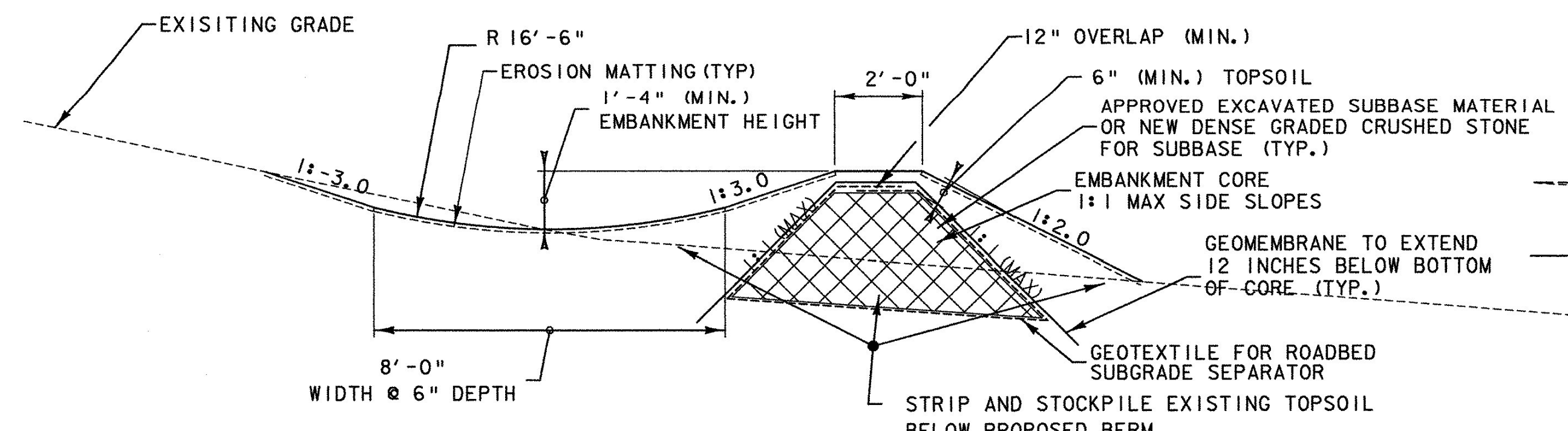

TYPICAL GRASS CHANNEL
RAMP "D" STA. 74+78+/- ~ 76+06+/- RT
NOT TO SCALE

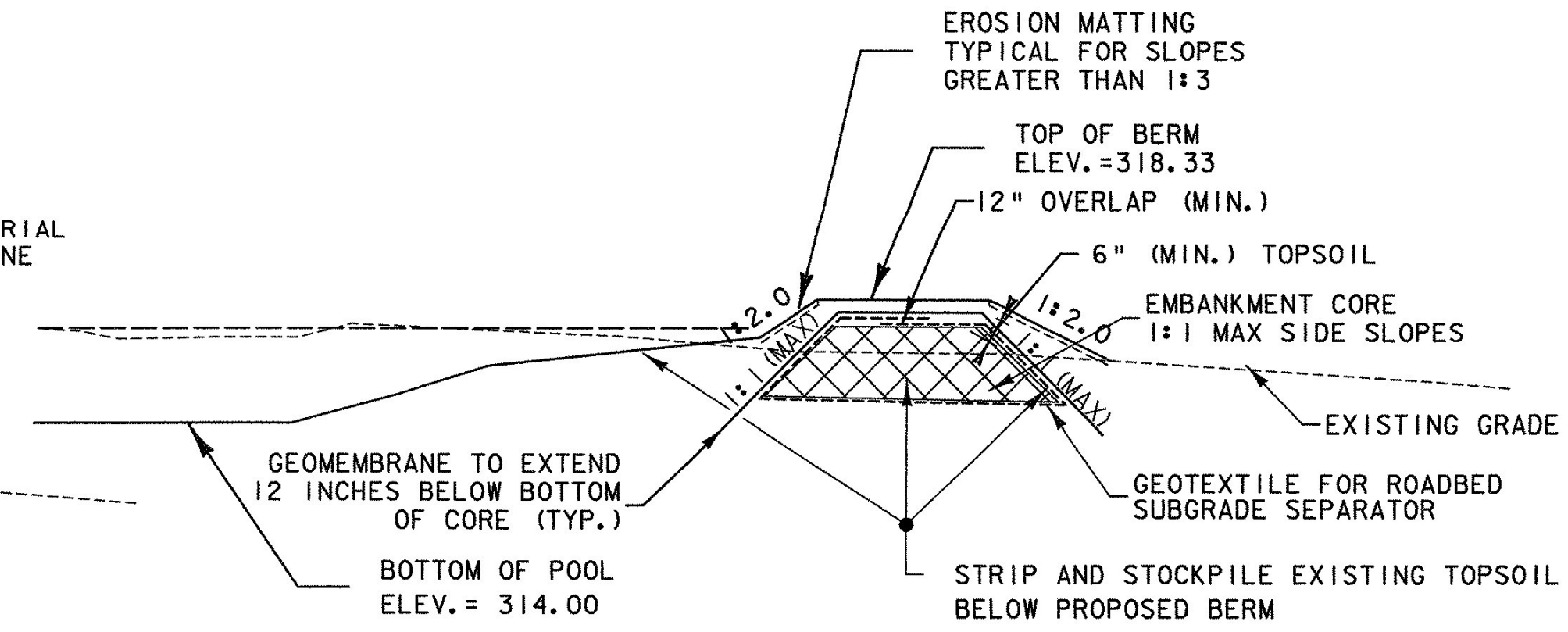

TYPICAL POOL EMBANKMENT DETAIL
RAMP "D" STA. 73+75+/- ~ 74+50+/- RT
NOT TO SCALE

EMBANKMENT NOTES:

- 1) IN AREAS WHERE THE CHANNEL BERM REQUIRES A RAISE IN GRADE GREATER THAN 6" EXISTING TOPSOIL, TOPSOIL FILLS, ORGANIC SOILS AND BOULDERS SHALL BE REMOVED AND TOPSOIL SHALL BE STOCKPILED FOR REUSE.
- 2) THE CONTRACTOR SHALL PROOF ROLL EXPOSED SUBGRADES WITH A VIBRATORY ROLLER TO IDENTIFY SOFT SPOTS. ANY SOFT SPOTS SHALL BE EXCAVATED AND BACKFILLED WITH SUITABLE MATERIAL.
- 3) THE CORE OF THE BERM SHALL BE CONSTRUCTED WITH APPROVED EXCAVATED SUBBASE MATERIAL FROM THE EXISTING ROADWAYS OR WITH NEW DENSE GRADED CRUSHED STONE FOR SUBBASE.
- 4) CONSTRUCT THE BERM CORE TO WITHIN 6" OF FINISHED GRADE IN 6" HORIZONTAL LIFTS. EACH LIFT SHALL BE COMPACTED IN ACCORDANCE WITH SECTION 203 OF THE STANDARD SPECIFICATIONS.
- 5) THE CONTRACTOR SHALL PLACE GEOTEXTILE FABRIC FOR ROADBED SUBGRADE SEPARATOR OVER THE CONSTRUCTED CORE WITH 12" MINIMUM OVERLAP AT ADJOINING PANELS.
- 6) THE CONTRACTOR SHALL PLACE GEOMEMBRANE OVER CORE. GEOMEMBRANE ENDS SHALL EXTEND 12" BELOW THE BOTTOM OF THE EARTH BERM CORE.
- 7) THE CONTRACTOR SHALL PLACE 6" OF APPROVED TOPSOIL OVER THE CONSTRUCTED CORE AND GEOMEMBRANE AND TAMP AND SEED.

GEOMEMBRANE LINER NOTES:

1. THE IMPERVIOUS GEOMEMBRANE SHALL BE AT LEAST 30 MILS IN THICKNESS AND SHALL CONSIST OF VIRGIN POLYVINYL CHLORIDE (PVC) RESINS, PLASTICIZER, STABILIZERS, AND SUCH MATERIALS THAT, WHEN COMPOUNDED, WILL MEET THE PHYSICAL REQUIREMENTS LISTED IN THE SPECIAL PROVISIONS.
2. INDIVIDUAL WIDTHS OF PVC MATERIALS SHALL BE FABRICATED INTO LARGE SECTIONS BY DIELECTRIC SEAMING INTO A SINGLE PIECE, OR INTO A MINIMUM NUMBER OF PANELS, AS REQUIRED TO FIT THE APPLICATION. LAP JOINTS WITH A MINIMUM JOINT WIDTH OF 3/4-INCHES SHALL BE USED.
3. A 6-INCH MINIMUM LAYER OF TOPSOIL SHALL BE PLACED OVER THE PVC LINING AS SHOWN ON THE DRAWINGS. COVER MATERIAL SHALL BE APPROVED BY THE RESIDENT ENGINEER PRIOR TO PLACEMENT. MATERIAL SOIL CONTAINING SHARP, JAGGED ROCKS, ROOTS, DEBRIS OR ANY OTHER MATERIAL, WHICH MAY PUNCTURE THE MEMBRANE, SHALL NOT BE USED AS COVER MATERIAL.
4. THE CONTRACTOR MAY CHOOSE THE EQUIPMENT AND MANNER WITH WHICH TO PLACE THE COVER OVER THE LINER, PROVIDED: THE CONTRACTOR SATISFACTORILY DEMONSTRATES TO THE ENGINEER THAT BOTH THE EQUIPMENT AND MANNER USED TO PLACE THE CHOSEN COVER MATERIAL OVER THE LINING WILL NOT HAVE ANY DETRIMENTAL EFFECTS ON THE LINER.
5. FIELD SEAMS WILL BE MADE TO SEAL FACTORY FABRICATED PANELS OF PVC TOGETHER IN THE FIELD. SEAMS SHALL BE FORMED BY LAPPING THE EDGES OF PANELS A MINIMUM OF 6-INCHES. THE CONTACT SURFACES OF THE PANELS SHALL BE WIPED CLEAN TO REMOVE ALL DIRT, DUST OR OTHER SUBSTANCE. SUFFICIENT VINYL TO VINYL BODIES SOLVENT SHALL BE APPLIED TO THE CONTACT SURFACE IN THE SEAM AREA, AND THE TWO SURFACES PRESSED TOGETHER IMMEDIATELY. ANY WRINKLES SHALL BE SMOOTHED OUT. FIELD SEAMS SHALL HAVE A STRENGTH OF AT LEAST 85% OF THE SPECIFIED SHEET STRENGTH.
6. ALL CURING COMPOUNDS AND COATINGS SHALL BE COMPLETELY REMOVED FROM THE JOINT AREA. JOINING OF THE PVC TO THE BACK OF PANEL SHALL BE DONE WITH AN ADHESIVE. UNLESS OTHERWISE SHOWN ON THE DRAWINGS, THE MINIMUM WIDTH OF CONCRETE TO PVC JOINT SHALL BE 6-INCHES. IN ADDITION, MECHANICAL ATTACHMENTS MAY BE NECESSARY. ANY NECESSARY REPAIRS TO THE PVC SHALL BE MADE WITH THE LINING MATERIAL ITSELF AND COLD APPLIED VINYL TO VINYL SPLICING ADHESIVES. PATCHES SHOULD BE CUT SO AS TO COVER THE AREA TO BE REPAIRED BY A MINIMUM OF 4-INCHES IN ALL DIRECTIONS. PATCHES SHOULD BE CUT WITH ROUNDED CORNERS. THE SPLICING ADHESIVE SHALL BE APPLIED TO THE CONTACT SURFACE BETWEEN THE PATCH AND THE LINING, AND THE TWO SURFACES PRESSED TOGETHER IMMEDIATELY. ANY WRINKLES SHALL BE SMOOTHED OUT.
- 7.

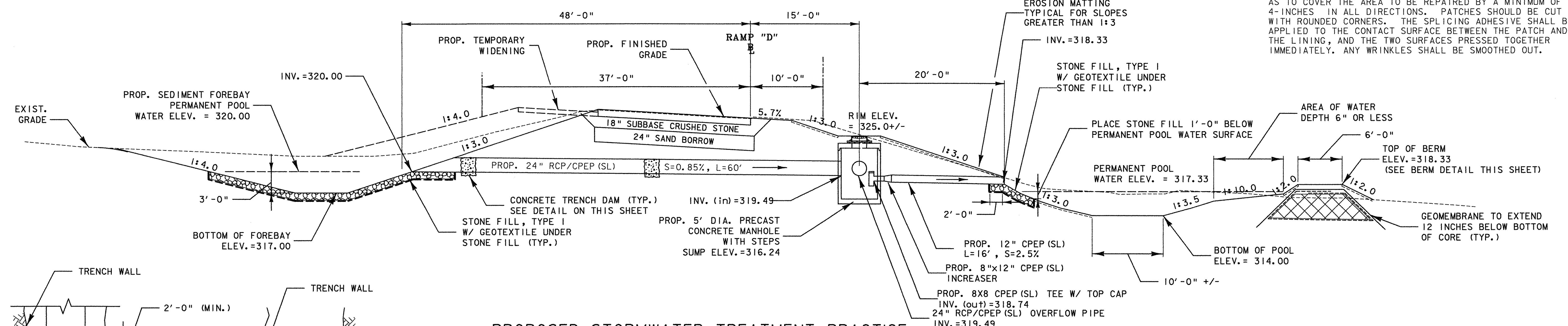

PROPOSED STORMWATER TREATMENT PRACTICE
RAMP "D" STA. 74+25
NOT TO SCALE

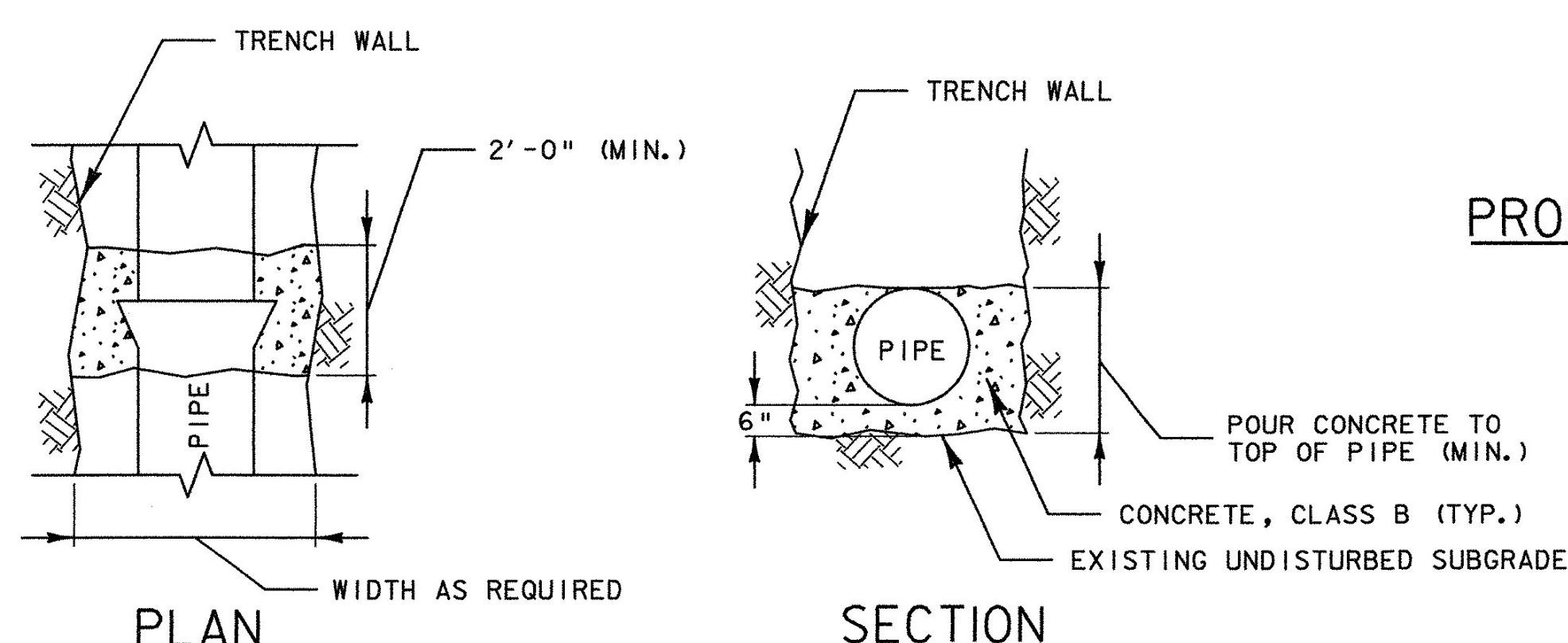

TYPICAL CONCRETE TRENCH DAM
NOT TO SCALE

PROJECT NAME:	SOUTH BURLINGTON
PROJECT NUMBER:	IM 089-3(37)
FILE NAME:	z03a178typ.dgn
PROJECT LEADER:	KEN UPMAL
DESIGNED BY:	E.ATKINS/P. MILEWSKI
PLOT DATE:	5/5/2006
DRAWN BY:	E.ATKINS
CHECKED BY:	K.JSHIKURA
SHEET	23 OF 99