

INTERSTATE TYPICAL PAVEMENT MARKINGS

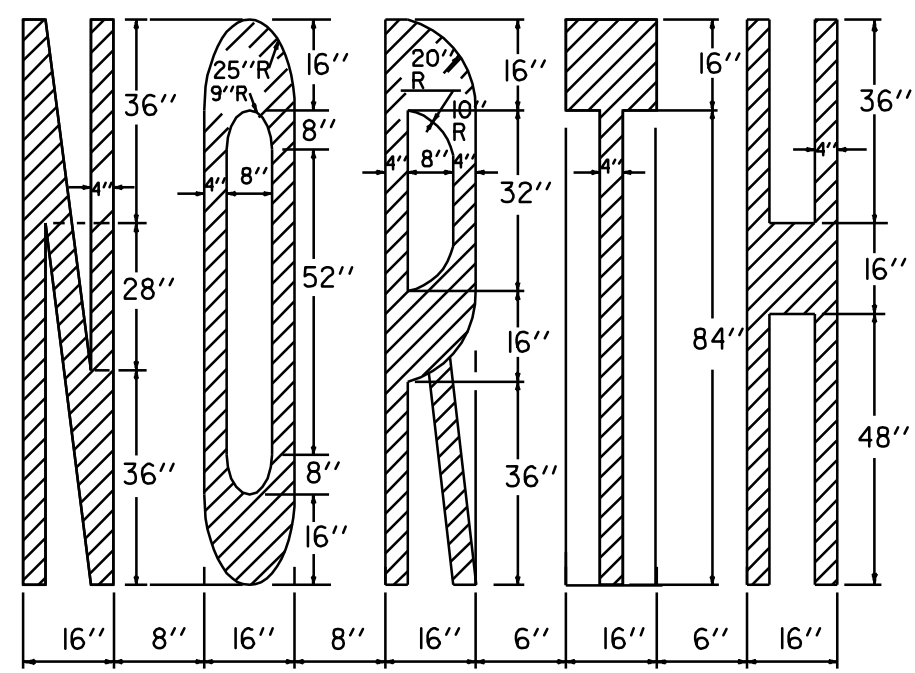

ADJUST TO AVAILABLE PAVEMENT WIDTH

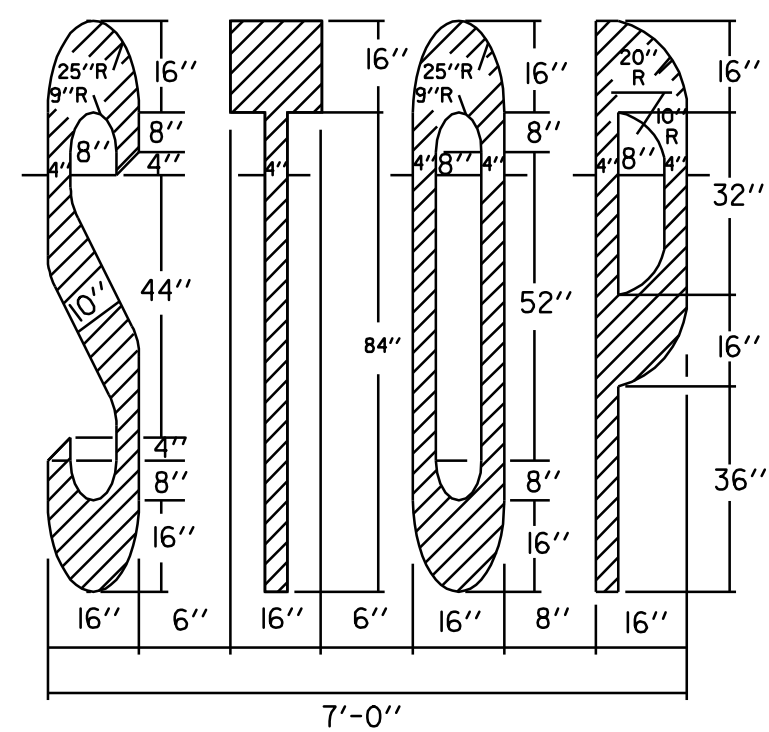

7'-0"

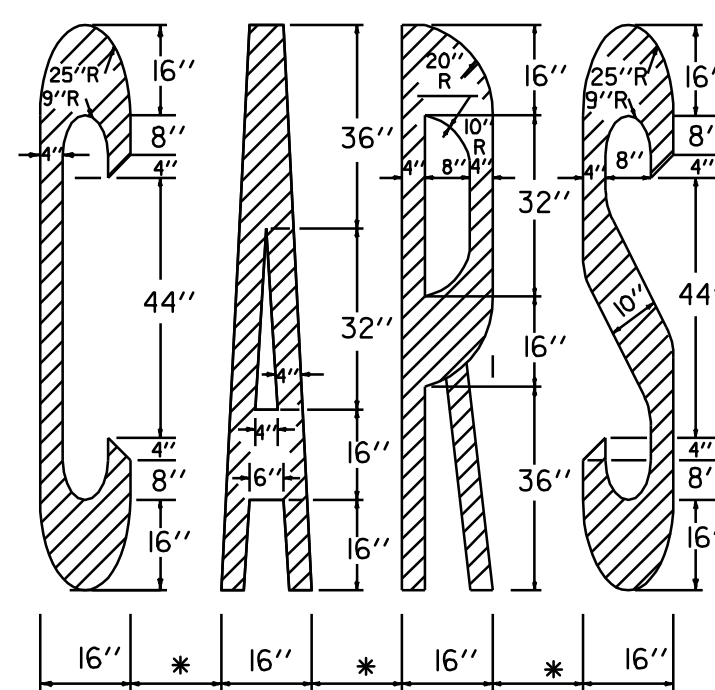

(* 6") - ADJUST TO AVAILABLE PAVEMENT WIDTH

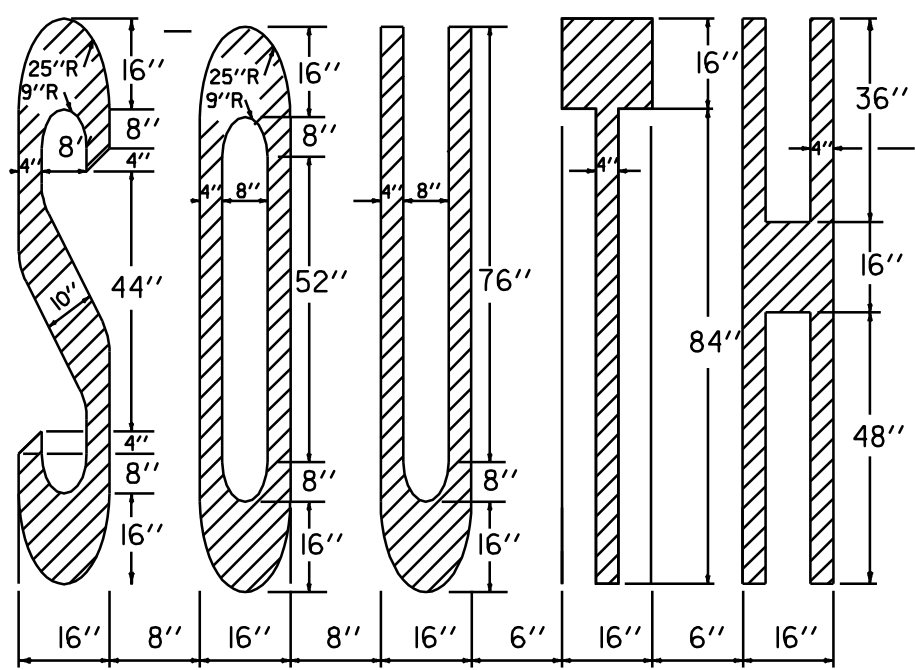

ADJUST TO AVAILABLE PAVEMENT WIDTH

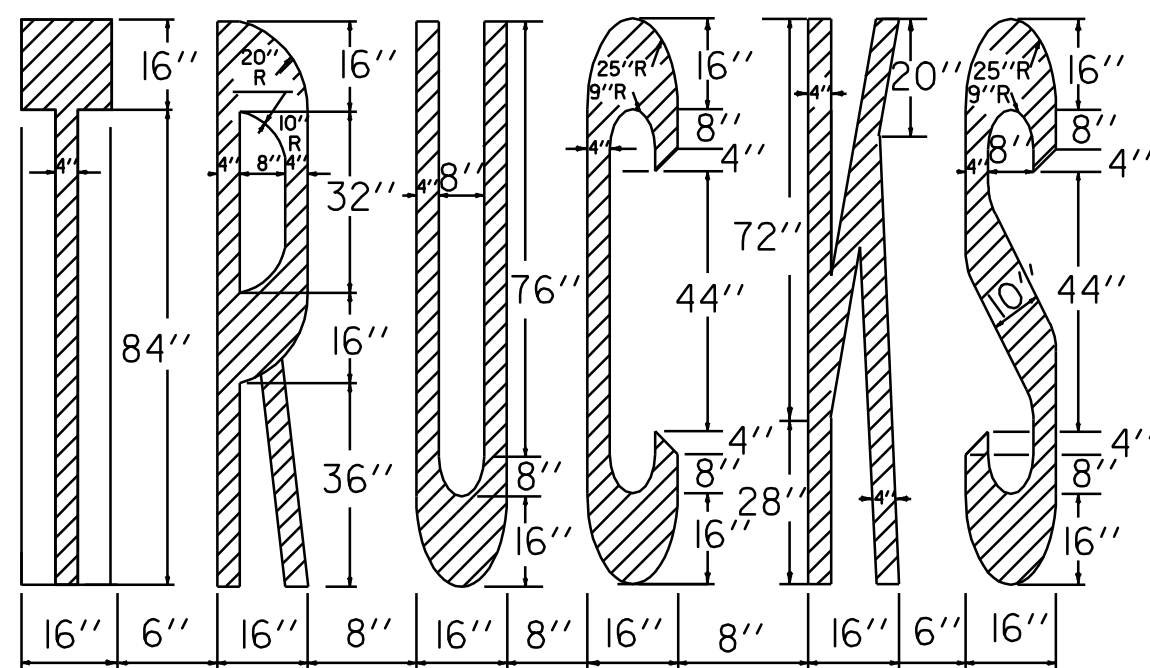
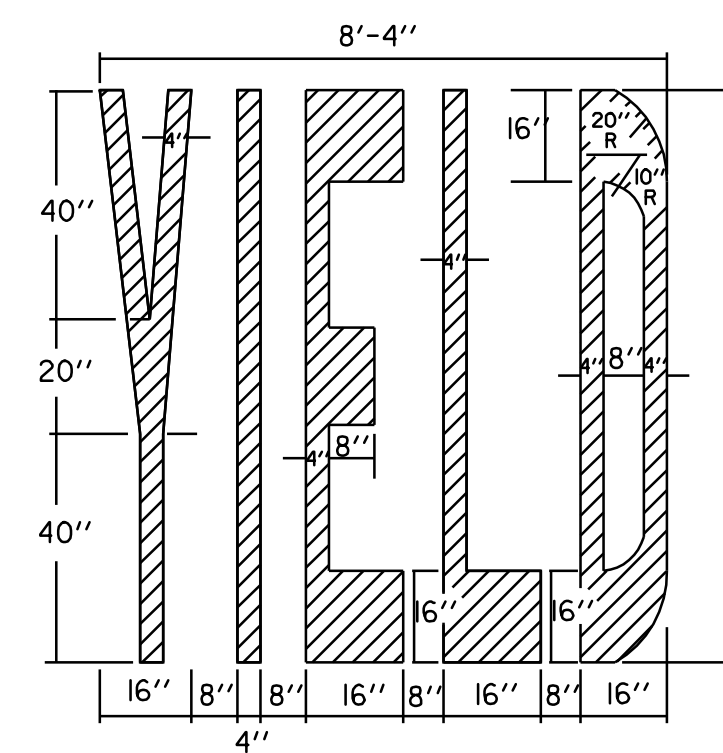

ADJUST TO AVAILABLE PAVEMENT WIDTH

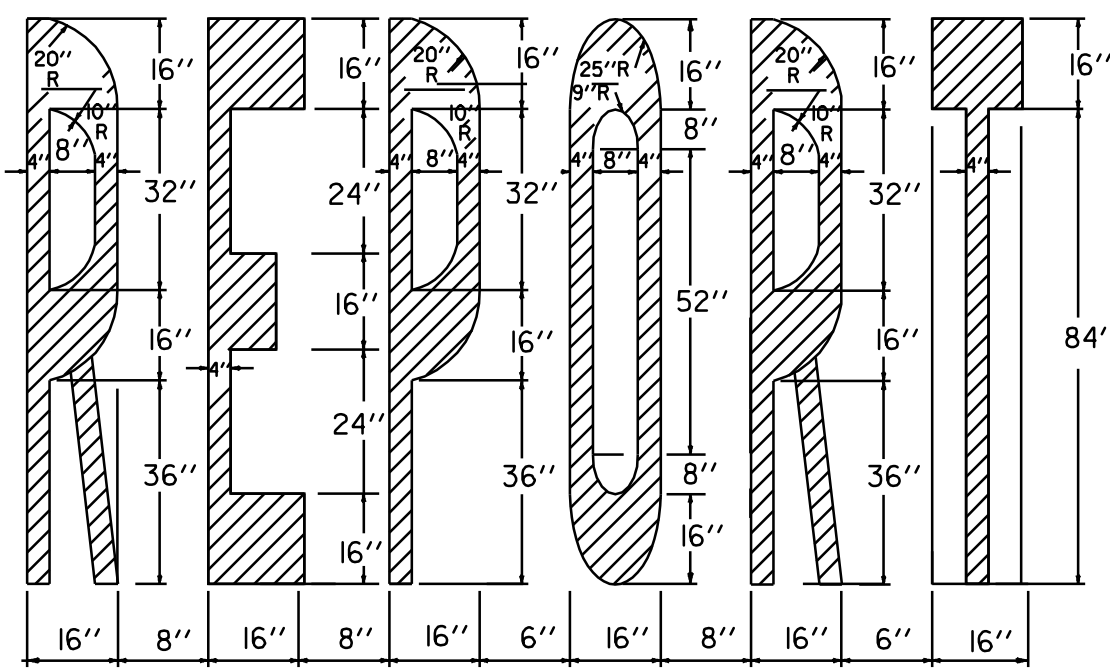

ADJUST TO AVAILABLE PAVEMENT WIDTH

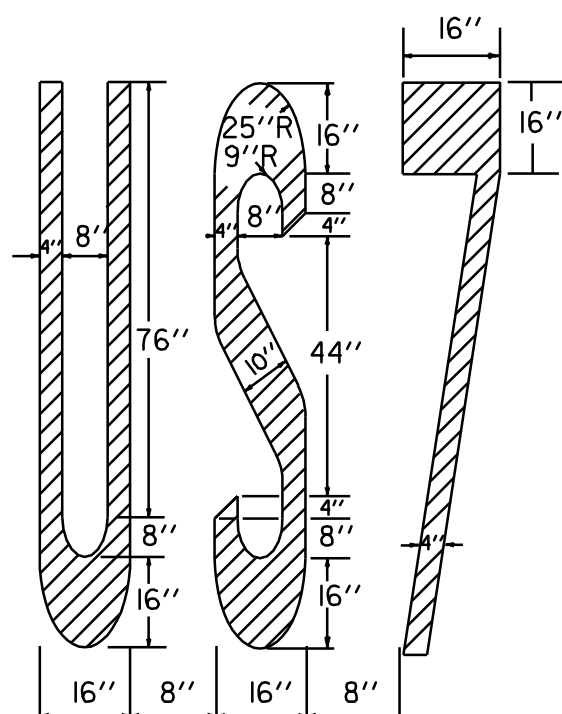
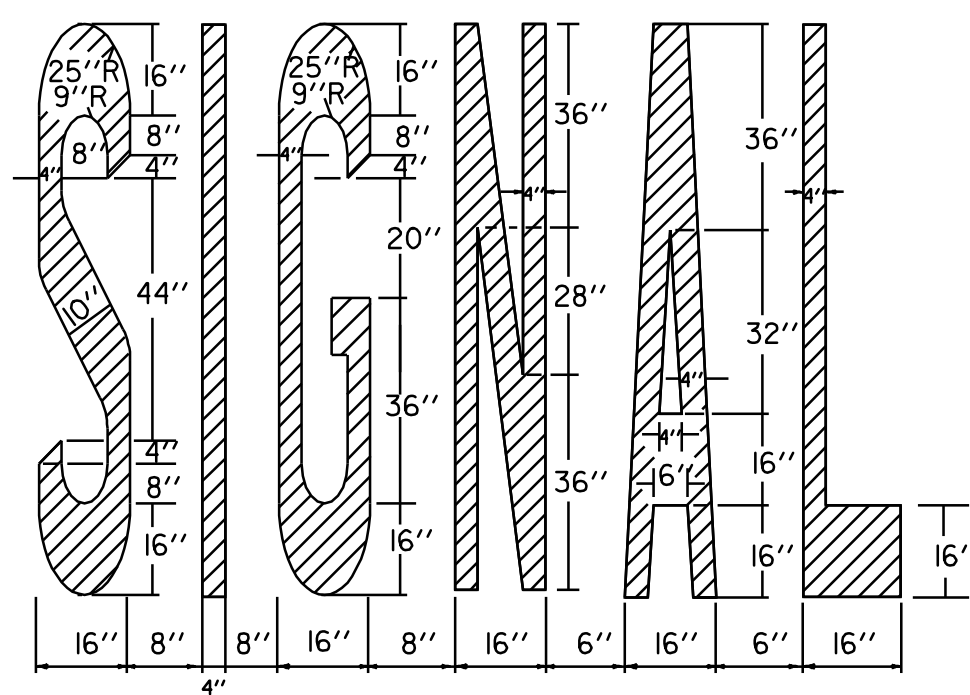

BLUE BACKGROUND
36" X 36" FOR MINIMUM
48" X 48" FOR STANDARD

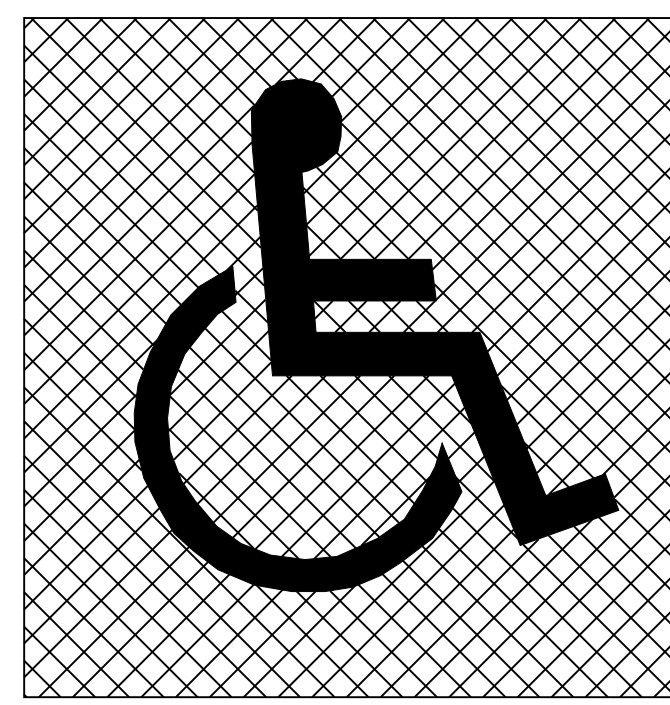

WIDTH OF SYMBOL MINIMUM 24"
STANDARD 36"

TO BE PAID AS TWO SYMBOLS

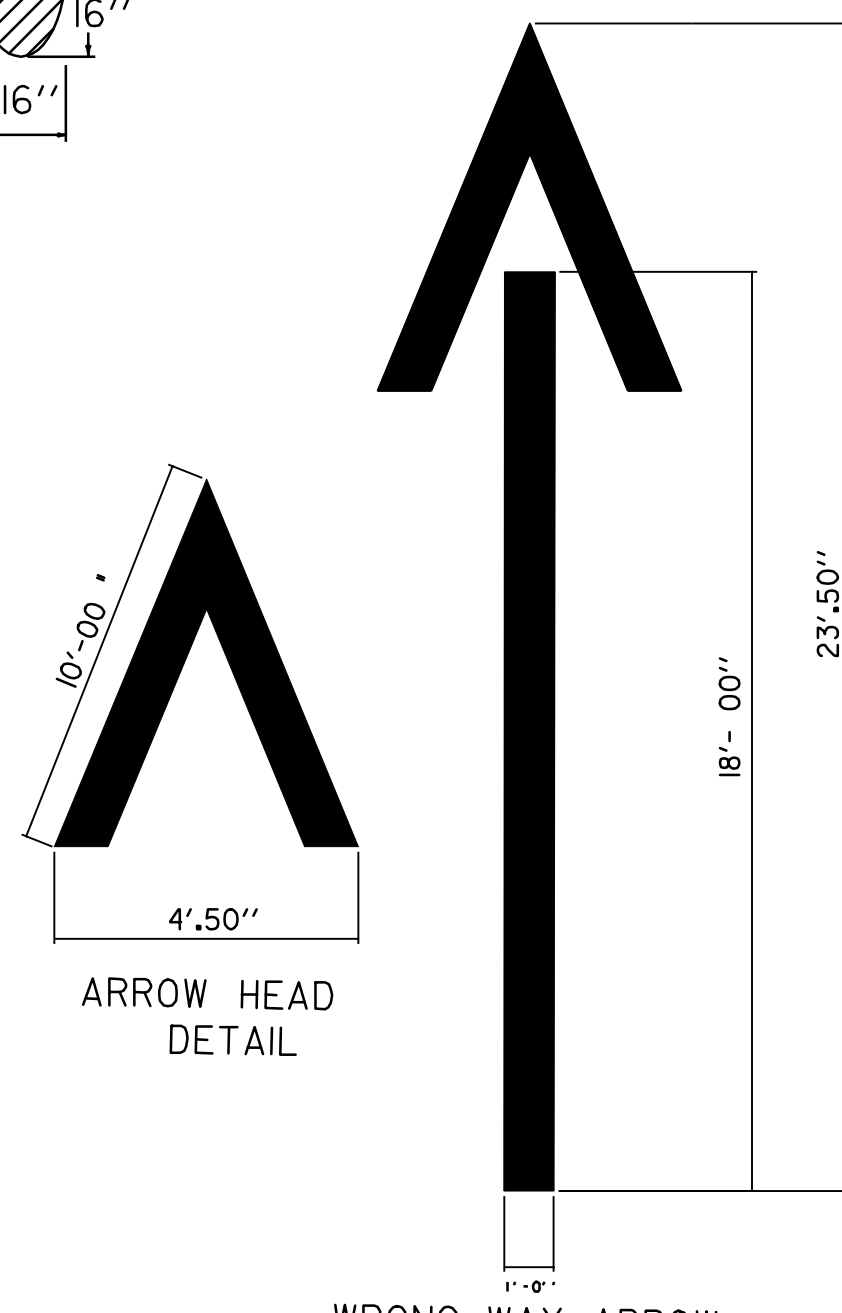
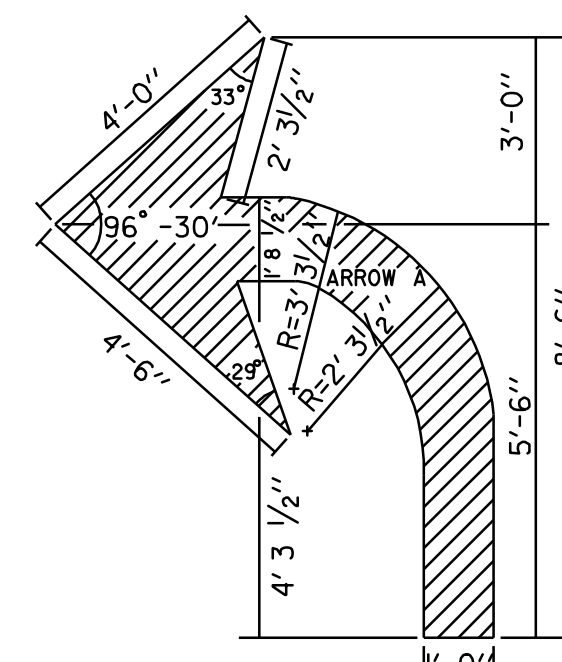
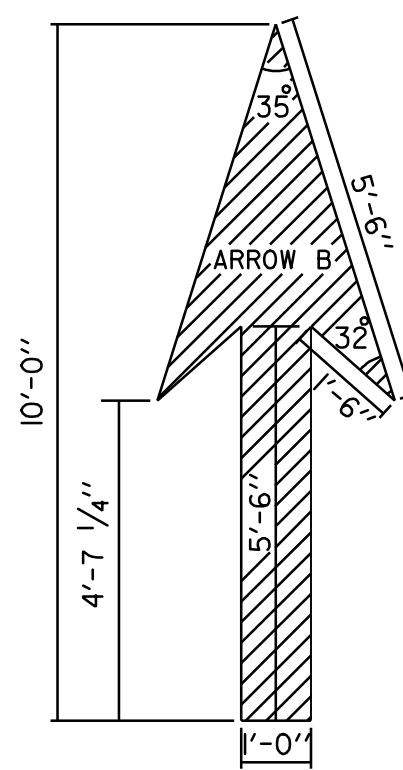

WRONG WAY ARROW

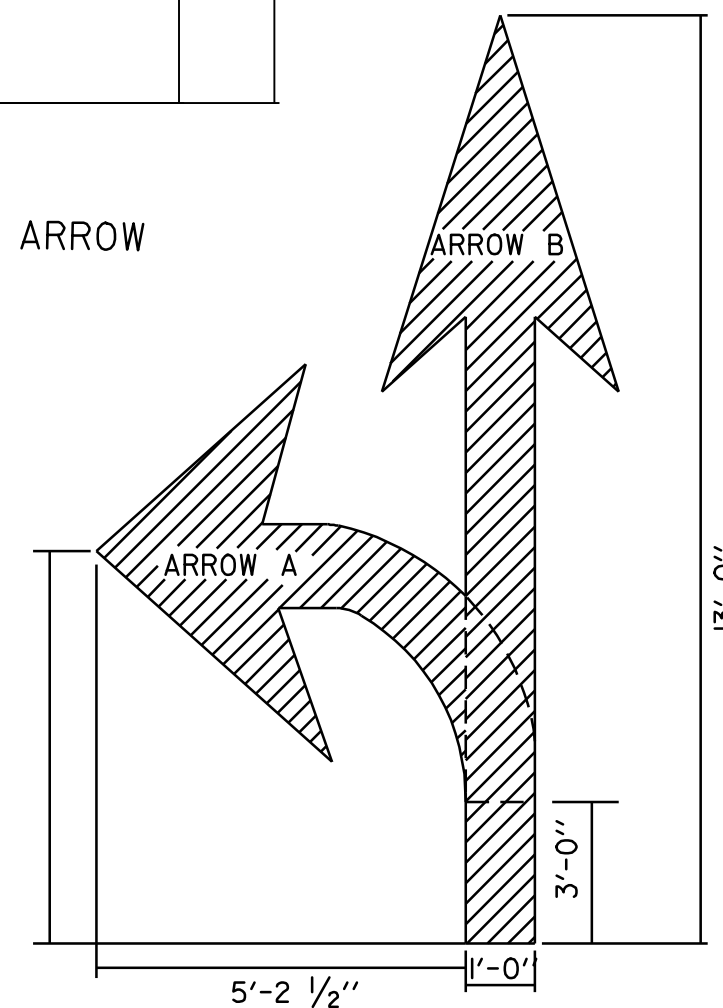

TO BE PAID AS TWO SYMBOLS

ARROW DETAILS

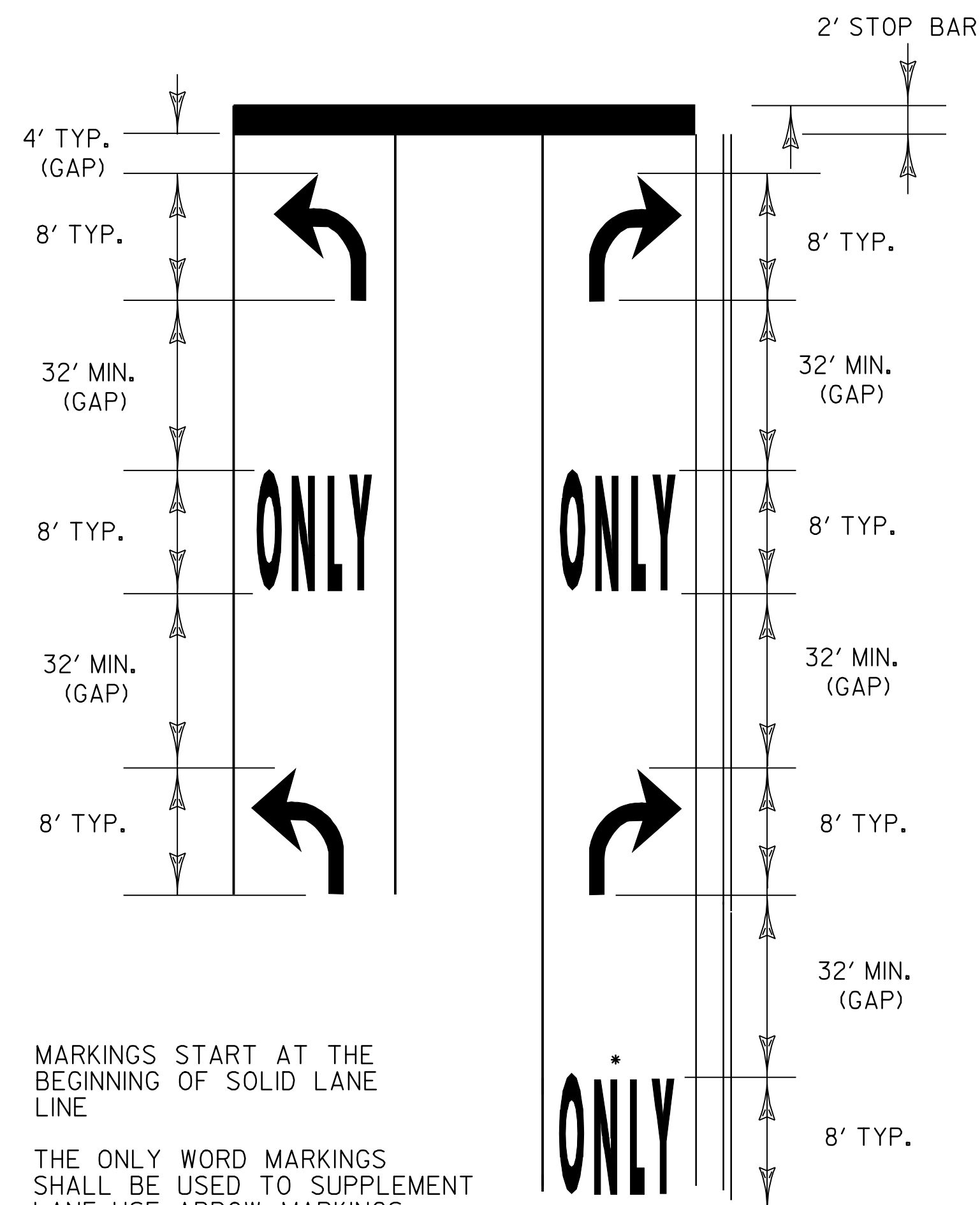

MARKINGS START AT THE BEGINNING OF SOLID LANE LINE

THE ONLY WORD MARKINGS SHALL BE USED TO SUPPLEMENT LANE-USE ARROW MARKINGS

IF LANE LENGTH IS LESS THAN 50 FEET, ONLY ONE TURN ARROW PLACED AT THE BEGINNING OF THE SOLID LANE LINE, IS REQUIRED.

THE LONGITUDINAL SPACE BETWEEN WORD OR SYMBOL MESSAGE MARKINGS, SHOULD BE AT LEAST FOUR TIMES THE HEIGHT OF THE CHARACTERS FOR LOW SPEED ROADS, BUT NOT MORE THAN TEN TIMES THE HEIGHT OF THE CHARACTERS UNDER ANY CONDITIONS.

* A SECOND "ONLY" IS OPTIONAL WHEN SPACE PERMITS. MARKINGS START AT THE BEGINNING OF THE SOLID LANE LINE.

EXCLUSIVE TURN LANES (LEFT OR RIGHT) LANE LINES SHALL BE SOLID AND EXTEND BACK FROM THE STOP LINE TO THE POINT OF FULL LANE WIDTH OF THE TURN LANE.

TYPICAL MARKINGS FOR TURN LANES

PAVEMENT MARKING DETAILS

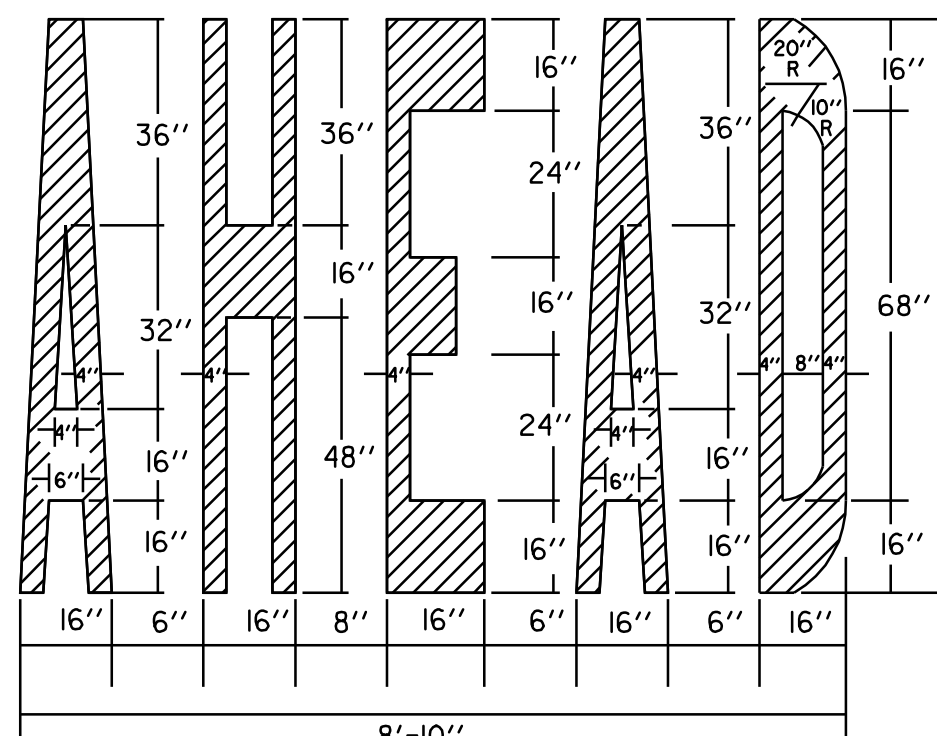
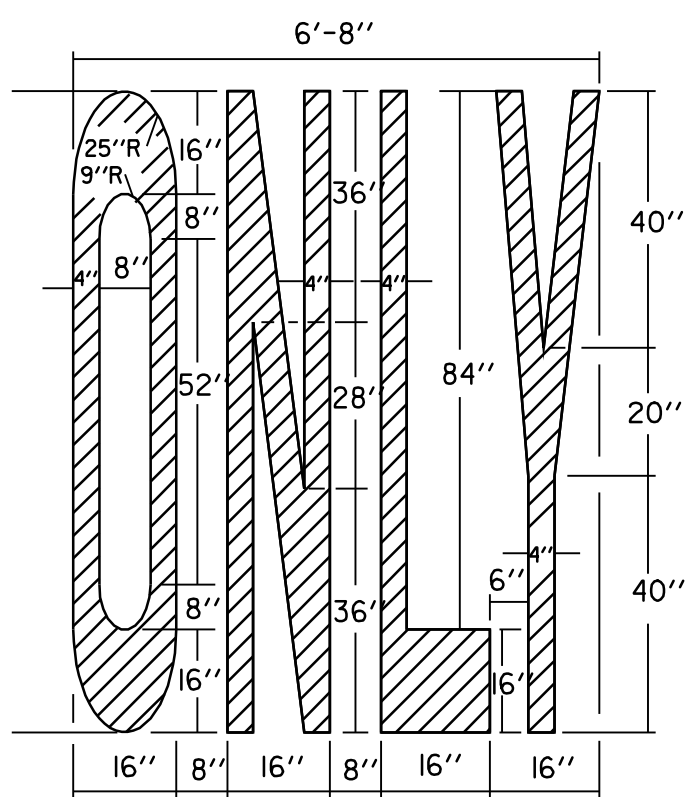

PROJECT NAME: FAIRLEE-NEWBURY	PLOT DATE: 12-MAR-2007 11:19
PROJECT NUMBER: AC IM 091-2(39)	DRAWN BY: JLR
FILE NAME: /pave/03a028/pa028.dgn	DESIGNED BY: JLR
PROJECT LEADER: WOOLAVER	CHECKED BY: JLR
DESIGNED BY: JLR	SHEET 23 OF 25
pa028d08.1	