

TEMPORARY AND DURABLE 6" WHITE LINE

ON RAMP 0+52 TO 6+00 SOLID RT (RAMP C)
 OFF RAMP 0+52 TO 0+81 SOLID LT (RAMP D)
 OFF RAMP 0+64 TO 6+00 SOLID LT (RAMP D)
 OFF RAMP 1+50 TO 2+84 DASHED LT (RAMP D)

TEMPORARY AND DURABLE 6" YELLOW LINE

OFF RAMP 0+55 TO 0+82 SOLID LT (ISLAND)
 OFF RAMP 0+55 TO 6+00 SOLID RT (RAMP D/C)
 ON RAMP 0+55 TO 6+00 SOLID LT (RAMP C/D)

TEMPORARY AND DURABLE 24" STOP BAR

OFF RAMP 0+55 LT
 OFF RAMP 0+64 LT

TEMPORARY AND DURABLE 12" WHITE LINE

OFF RAMP 0+81 TO 1+02 SOLID LT
 OFF RAMP 0+81 TO 1+50 SOLID LT

TEMPORARY AND DURABLE LETTER OR SYMBOL

OFF RAMP 0+63 LT - "STOP" (RAMP D)
 OFF RAMP 0+63 LT - "STOP" (RAMP D)
 OFF RAMP 1+46 LT - RIGHT TURN ARROW (RAMP D)
 OFF RAMP 2+17 LT - "ONLY" (RAMP D)
 OFF RAMP 2+80 LT - RIGHT TURN ARROW (RAMP D)
 OFF RAMP 3+55 LT - WRONG WAY ARROW (RAMP D)

BITUMINOUS CONCRETE GUTTERS AND TRAFFIC ISLANDS

OFF RAMP 2+35 LT (PAVE ONLY) (RAMP D)

PAINTED CURB

STA 0+75 TO 1+05 LT & RT
 STA 3+54 TO 3+84 LT & RT

REHABING DI, CB OR MH

OFF RAMP 0+87 LT (RAMP D) CLASS I
 ON RAMP 0+87 RT (RAMP C) CLASS I

DELINEATORS OFF RAMP D 0+67 LT.

REFER TO STANDARDS E-197, E-198 AND E-199 FOR PLACEMENT GUIDELINES

REMOVING SIGNS

AS SHOWN - 6

**EXIT 2 - RAMP CD
 SOUTHBOUND ON/OFF RAMP**

SEE STANDARDS E-191, E-192 AND E-193 FOR PAVEMENT MARKING GUIDELINES

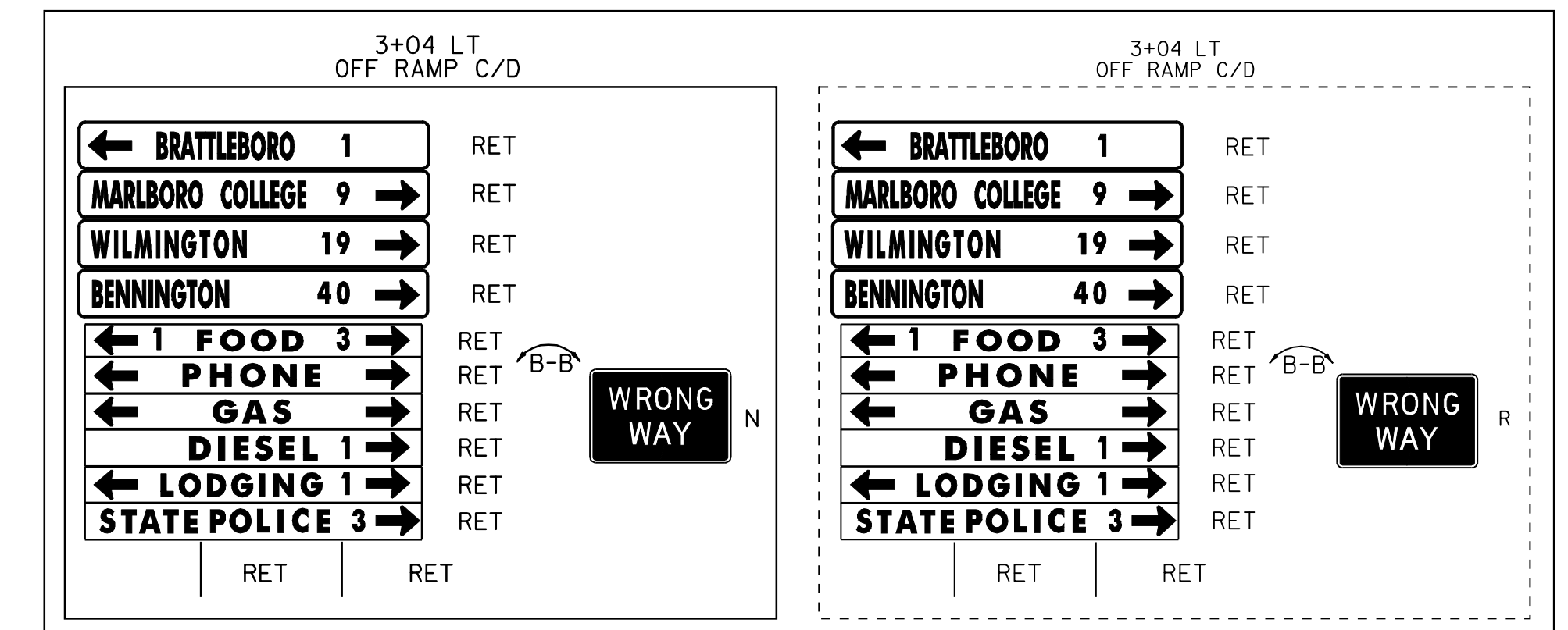
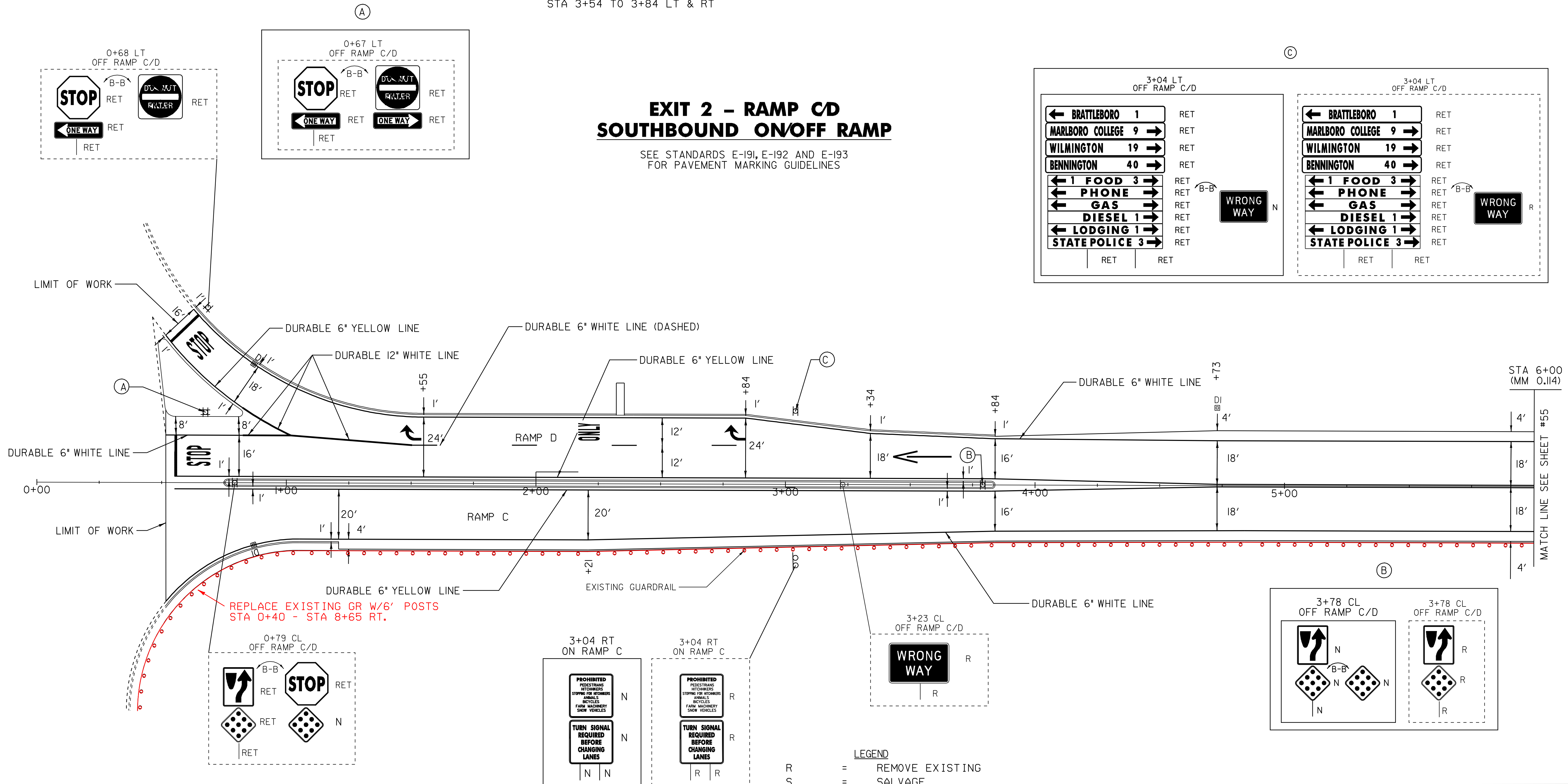

DATUM

VERTICAL	_____
HORIZONTAL	_____

- LEGEND**
- R = REMOVE EXISTING
 - S = SALVAGE
 - R & S = REMOVE AND SALVAGE
 - N = NEW
 - RET = RETAIN
 - B-B = BACK TO BACK
 - = NEW RAIL
 - - - = EXISTING RAIL

RAMP DETAIL #8	PROJECT NAME: GUILFORD-BRATTLEBORO
	PROJECT NUMBER: AC IM 091-K(54)
	FILE NAME: 05A014rd08.1
	CLD REF. NO. 05-0387
	PLOT DATE: 22-JAN-2009 13:4
	DRAWN BY: MRS
	CHECKED BY: NLL
	SHEET 54 OF 69

NOT TO SCALE