

ROUND ALUMINUM AND STEEL POLES

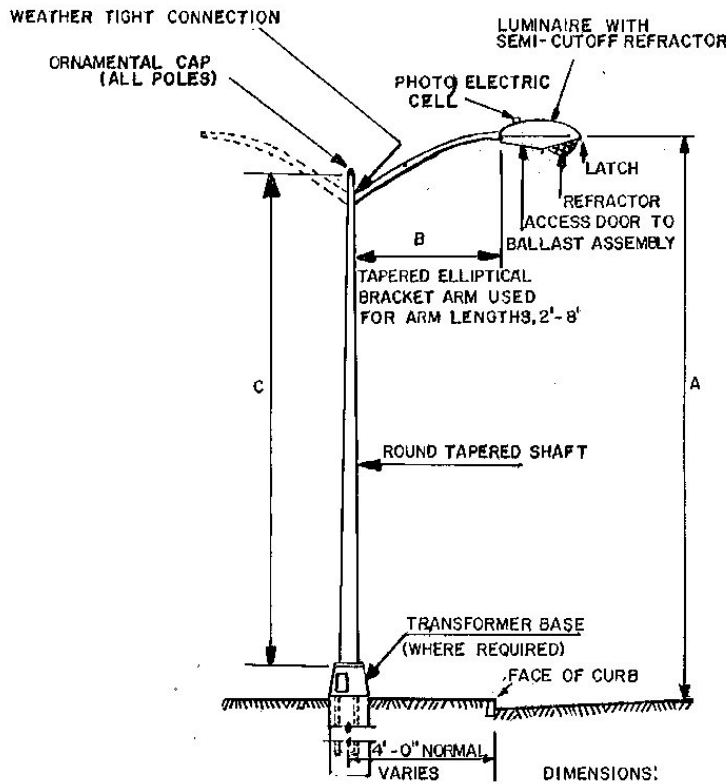
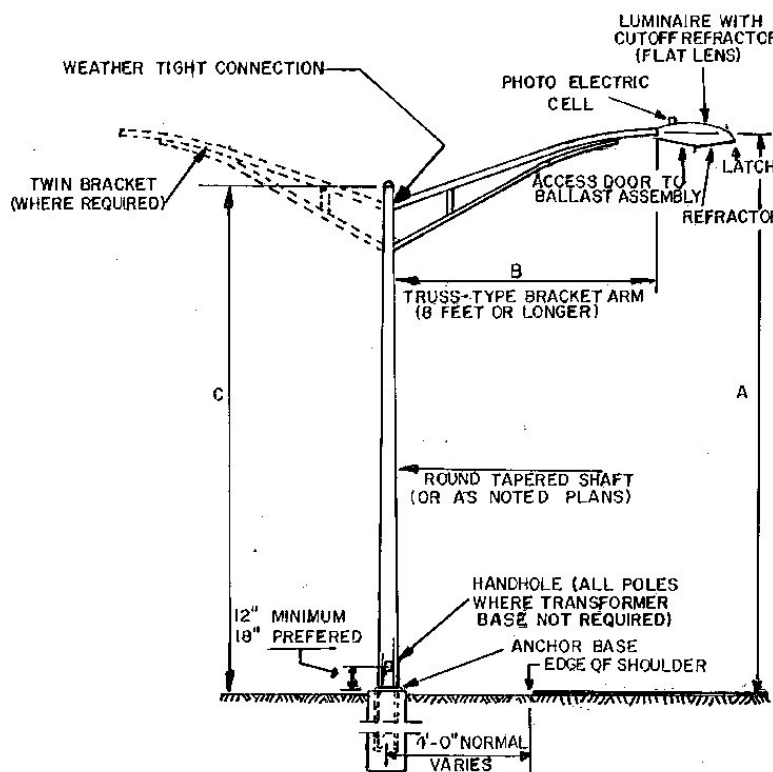

ALL POLES TO BE EQUIPPED WITH ANCHOR BASES UNLESS OTHERWISE INDICATED.
 ALL BRACKETS TO BE EQUIPPED WITH 2" SLIPFITTER FOR MOUNTING LUMINAIRE UNLESS OTHERWISE INDICATED.

BASES

DIMENSIONS SHOWN FOR ANCHOR BASES AND TRANSFORMER BASES MAY VARY SLIGHTLY WITH DIFFERENT MANUFACTURERS.

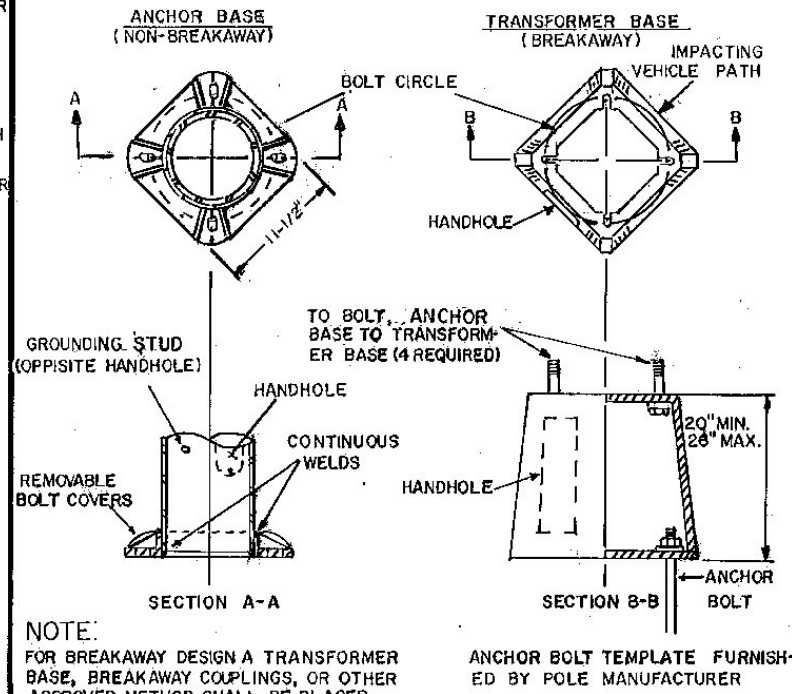

POLES, ANCHOR BASES, ARMS, AND LUMINAIRES. GENERAL NOTES

1. NO POLE SHALL BE INSTALLED WITHOUT A LUMINAIRE.
2. ANCHOR BASE AND ANCHOR BOLT DIMENSIONS SHOWN ARE FOR A SINGLE ARM POLE OF HEIGHT 35 FEET OR LESS. SEE PLANS FOR OTHER CONDITIONS.
3. ALL POLES OF THE BREAKAWAY DESIGN SHALL YIELD OR BREAKAWAY WITH A CHANGE IN VEHICLE MOMENTUM OF LESS THAN 1100 POUND-SECONDS WHEN STRUCK BY 2250 POUNDS AT 20 M.P.H. TO 60 M.P.H.
4. A 12 FOOT OR LONGER ARM REQUIRES A 6 INCH OUTSIDE DIAMETER POLE TOP.
5. LUMINAIRES SHALL MEET SPECIFICATIONS AS SHOWN ON THE PLANS.
6. ALL ELECTRICAL MATERIAL AND ELECTRICAL WORK SHALL BE SUBJECT TO INSPECTION AND APPROVAL BY THE AREA ELECTRICAL INSPECTOR AND/OR THE POWER COMPANY WITH JURISDICTION IN THE PROJECT AREA.
7. ALL WORK MUST MEET THE REQUIREMENTS OF THE NATIONAL ELECTRICAL CODE, AS WELL AS LOCAL AND STATE CODES.
8. ALL STREET LIGHT POLES SHALL HAVE A METAL TAG ATTACHED TO THE HANDHOLE WITH THE POLE NUMBER, WATTAGE AND TYPE OF LAMP. EXAMPLE, NO. 2-150W.-H.P.S. (H.P.S.=HIGH PRESSURE SODIUM). MINIMUM LETTER SIZE 1/2 INCH HIGH. PAYMENT FOR TAGS WILL BE SUBSIDIARY TO ITEM 679.15, STREET LIGHTING.
9. POLES, BASE PLATES, ANCHOR BOLTS AND ARMS SHALL MEET THE SPECIFICATION OF THE LATEST EDITION OF AASHTO-AGC-ARTBA'S GUIDE TO STANDARDIZED HIGHWAY LIGHTING POLE HARDWARE.

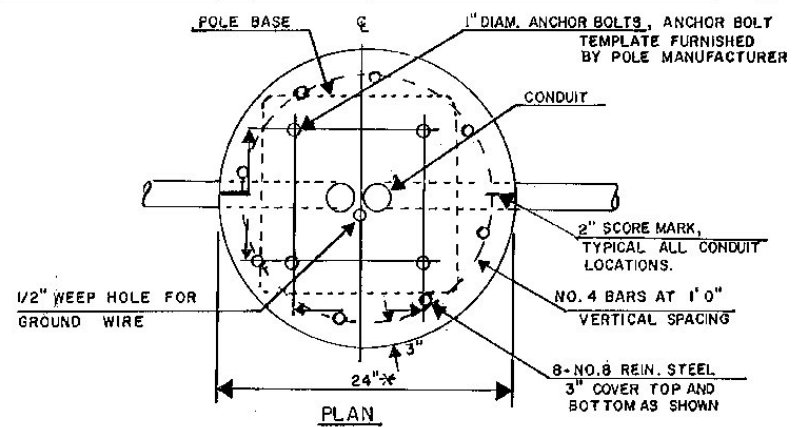

*USE 30" WITH TRANSFORMER BASES, ARM OVER 8' LONG OR WHEN OTHERWISE NOTED.

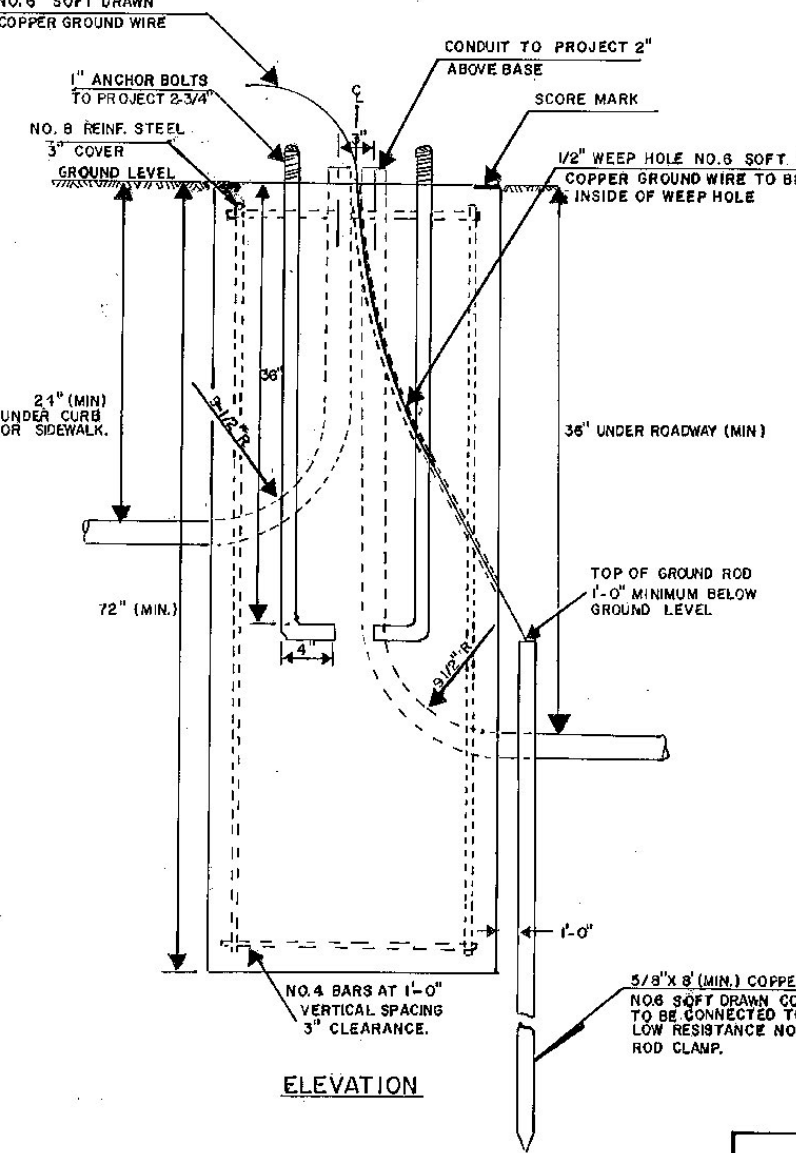

CONCRETE BASE

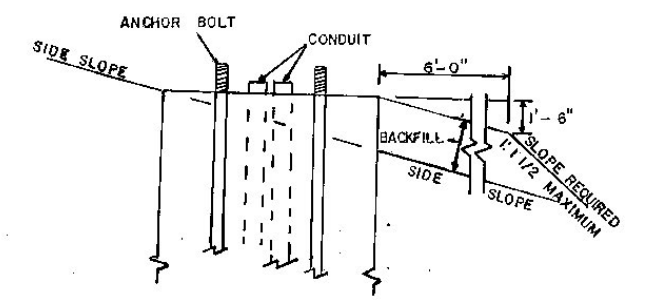
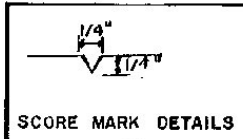

CONCRETE BASE NOTES

1. ALL CONCRETE BASES TO BE CONCRETE, CLASS B
2. ALL REINFORCING STEEL TO CONFORM TO THE REQUIREMENTS FOR "REINFORCING STEEL"
3. TEMPLATE FOR ANCHOR BOLTS, ANCHOR BOLTS, NUTS AND WASHERS TO BE OBTAINED BY CONTRACTOR FROM MANUFACTURER PRIOR TO CONSTRUCTION OF BASES.
4. SCORE TOP OF CONCRETE BASE TO SHOW LOCATION OF CONDUIT (S).
5. CONDUIT SIZE - AS SHOWN ON THE PLANS.
6. ALL EXPOSED METAL HARDWARE SHALL BE GALVANIZED OR STAINLESS STEEL.

REVISIONS AND CORRECTIONS
 JUNE 17, 1985 TRANSFORMER BASE STD. VEHICLE PATH CHANGED. SLOPE TREATMENT FOR CONCRETE BASE CHANGED.

APPROVED
 DATE JULY 20, 1984
 S. J. Gane
 DIRECTOR OF ENGINEERING AND CONSTRUCTION
 Arthur Ross
 CHIEF OF DESIGN
 H. B. Emerson
 SURVEY AND PLANS ENGINEER

STREET LIGHTING ITEM DETAILS



STANDARD E-39