

TYPICAL PLACEMENT OF TYPE I DELINEATORS AND MILEPOSTS ON INTERSTATE ROUTES

TYPE I DELINEATORS WITH WHITE REFLECTOR UNITS AND THE APPROPRIATE MILEPOST PLAQUES SHALL BE ERECTED CONTINUOUSLY ALONG THE RIGHT SIDE OF THE INTERSTATE ROADWAYS BETWEEN MILEMARKERS, EXCEPT THAT BEHIND GUARD RAIL MILEPOSTS WITHOUT REFLECTORS SHALL BE ERECTED.

THE TYPE I DELINEATORS AND MILEPOSTS SHALL BE OMITTED ALONG DECELERATION AND ACCELERATION LANES, BUT THE SUCCEEDING SPACING SHALL BE AS IF THE DELINEATORS HAD BEEN ERECTED CONTINUOUSLY AND SHALL BE SO INDICATED.

THE LOCATION OF TYPE I DELINEATORS AND MILEPOSTS ARE TO BE COMPUTED AND MARKED IN THE FIELD BY THE ENGINEER IN ACCORDANCE WITH THE LATEST REVISION OF THE AGENCY'S POLICY ON LOCATION MARKING FOR VERMONT INTERSTATE HIGHWAYS.

TYPE I DELINEATORS WITHOUT MILEPOST PLAQUES SHALL BE ERECTED CONTINUOUSLY ALONG THE LEFT OR MEDIAN SIDE OF THE INTERSTATE HIGHWAYS EXCEPT BEHIND GUARD RAIL, SPACED OPPOSITE EVERY SECOND TYPE I DELINEATOR ON THE RIGHT SIDE, AND CONTINUED AT APPROXIMATELY THE SAME SPACING THROUGH INTERCHANGES AND REST AREAS WHERE THERE MAY NOT BE ANY TYPE I DELINEATORS ON THE RIGHT SIDE. THE SAME LATERAL PLACEMENT SHALL BE FOLLOWED ON THE LEFT AS ON THE RIGHT. THE REFLECTIVE UNITS SHALL BE AMBER IN COLOR.

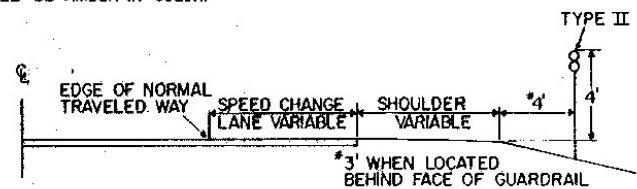

TYPICAL PLACEMENT OF TYPE II DELINEATORS ON SPEED CHANGE LANES

TYPE II DELINEATORS SHALL BE ERECTED CONTINUOUSLY ALONG THE RIGHT SIDE OF THE DECELERATION AND ACCELERATION LANES AT 100' INTERVALS AND SHALL NOT BE OMITTED BEHIND GUARDRAIL SECTIONS AS IS THE CASE FOR TYPE I DELINEATORS. THE DELINEATORS SHALL START AT THE BEGINNING OF THE TAPER AND END AT THE NOSE OF THE EXIT OR ENTRANCE GORE. THEY SHALL HAVE WHITE REFLECTOR UNITS.

TYPE III DELINEATORS
SEE NOTE #1

TYPE III DELINEATORS SHALL BEGIN 50' FROM WRONG WAY SIGNS AND EXTEND EVERY 50' TO A POINT NOT LESS THAN 25' FROM THE INTERSECTING ROADWAY AND BE MOUNTED ON BOTH SIDES OF THE ROAD.

DELINEATORS WITH ACRYLIC PLASTIC REFLECTORS

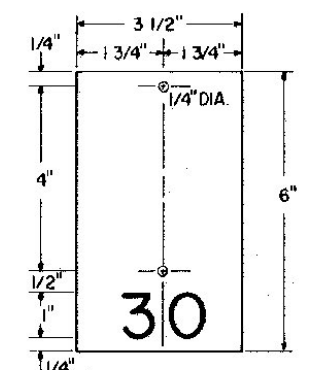
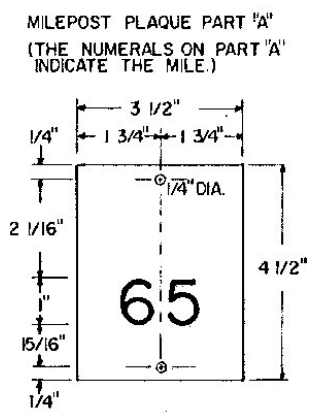

MILEPOST PLAQUE PART "B"
(THE NUMERAL ON PART "B" INDICATES UNITS OF FIVE ONE-HUNDRETHS OF A MILE BETWEEN MILE POSTS.)

TYPE II

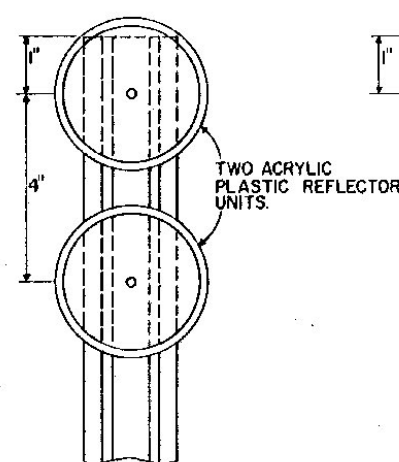

TYPE I WITHOUT PLAQUE

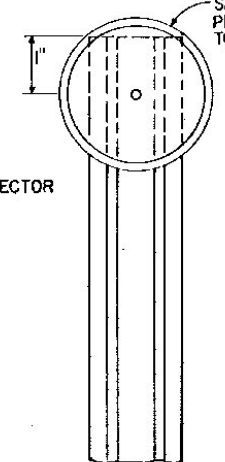

TYPE I WITH PLAQUE

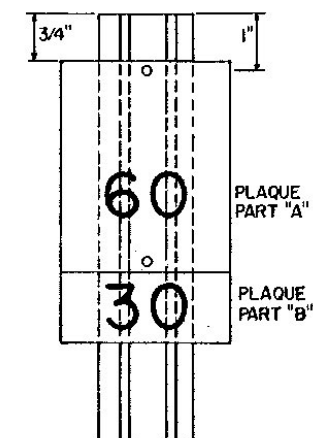
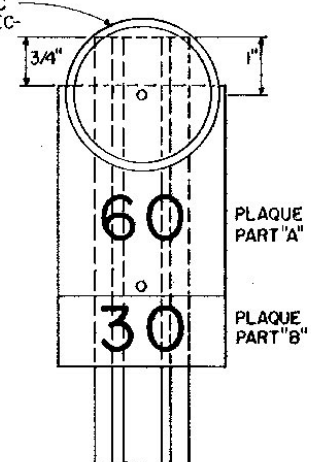

MILE POST WITHOUT REFLECTOR

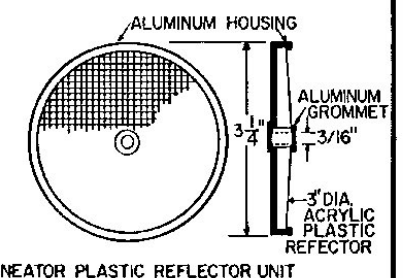

DELINEATOR PLASTIC REFLECTOR UNIT

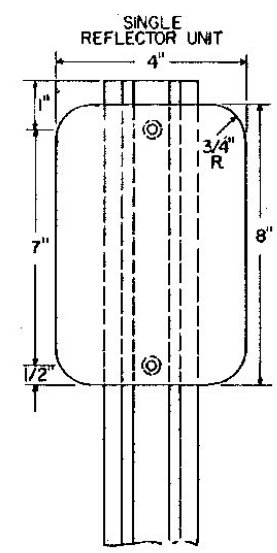

TYPE II

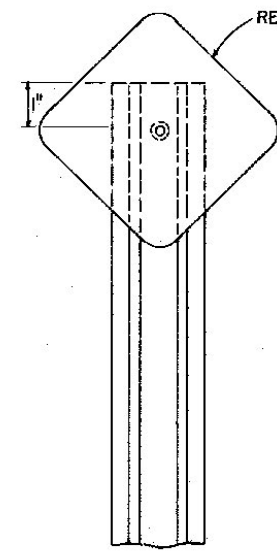

TYPE I WITHOUT PLAQUE

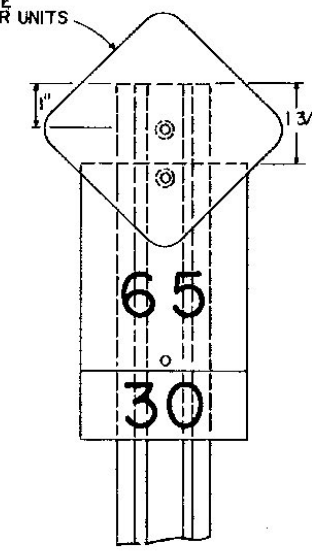

TYPE I WITH PLAQUE

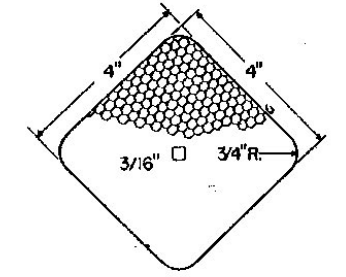

DELINEATOR REFLECTIVE SHEETING UNIT

MATERIAL FOR REFLECTIVE SHEETING DELINEATORS SHALL BE A 0.063" ALUMINUM BACKING WITH A SILVER, AMBER OR RED HIGH INTENSITY REFLECTIVE SHEETING.

NOTES

- TYPE III DELINEATORS WILL BE TYPE I DELINEATORS WITH AN ADDITIONAL RED REFLECTIVE UNIT MOUNTED ON THE REVERSE SIDE. THEY SHALL BE ERECTED ON THE RIGHT AND LEFT SIDE OF THE RAMPS AS INDICATED ON THE PLANS.
- EACH UNIT COMPLETE IN PLACE OF DELINEATOR TYPE I WITH OR WITHOUT PLAQUE, DELINEATOR TYPE II, DELINEATOR TYPE III OR MILEPOST WITHOUT REFLECTOR SHALL BE PAID FOR AS DELINEATOR, PAY ITEM 676.10.
- FOR MOUNTING DELINEATORS AND MILEPOSTS ON BRIDGES, SEE STANDARD E-32.
- DELINEATOR POSTS SHALL HAVE A MINIMUM EMBEDMENT OF 2'-3" IN THE GROUND.

DELINEATORS WITH REFLECTIVE SHEETING

A DELINEATOR REFLECTOR UNIT WITH ITS MILEPOST PLAQUE SHALL BE MOUNTED ON THE POST WITH TWO OR THREE 3/16" DIA. BY 1 1/2" LONG ALUMINUM BOLTS WITH 1/2" DIA. ALUMINUM VANDAL RESISTANT NUTS, OR A 3/16" DIA. BY 1 1/2" LONG VANDAL RESISTANT FASTENERS.

YY = 0.11 IN³ MIN.
XX = 0.08 IN³ MIN.

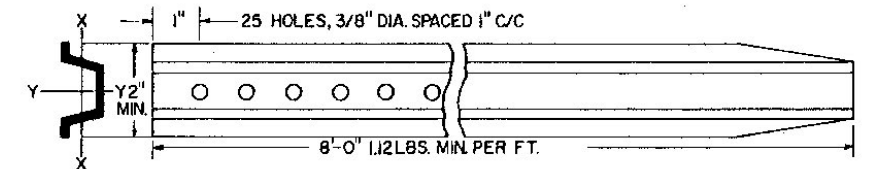

REVISIONS AND CORRECTIONS
DEC. 12, 1973 - REFERENCE TO E-20A CHANGED TO E-32.
SEPT. 7, 1979 - TYPE III DELINEATOR ADDED, REFLECTOR UNIT COLORS CHANGED TO CONFORM TO MUTCD.
DEC. 13, 1979 - REFLECTIVE CRITERIA DELETED.
JULY 17, 1981 - POST WEIGHT CHANGE, DELINEATOR OFFSET REVISED.
AUG. 25, 1981 - CORRECTIONS MADE, POST LENGTH CHANGED.
FEB. 23, 1984 - ADDED SECOND TYPE III DELINEATOR NOTE.
FEB. 3, 1986 - UPDATED TO 1986 SPECIFICATIONS

APPROVED: *Dec 29, 1971*
DATE
P.W. Arnold
CHIEF ENGINEER
E.H. Stinchney
ASST. CHIEF ENGINEER
G.M. Lane
HIGHWAY ENGINEER

DELINEATORS AND MILEPOSTS



STANDARD
E-30