

PLAN

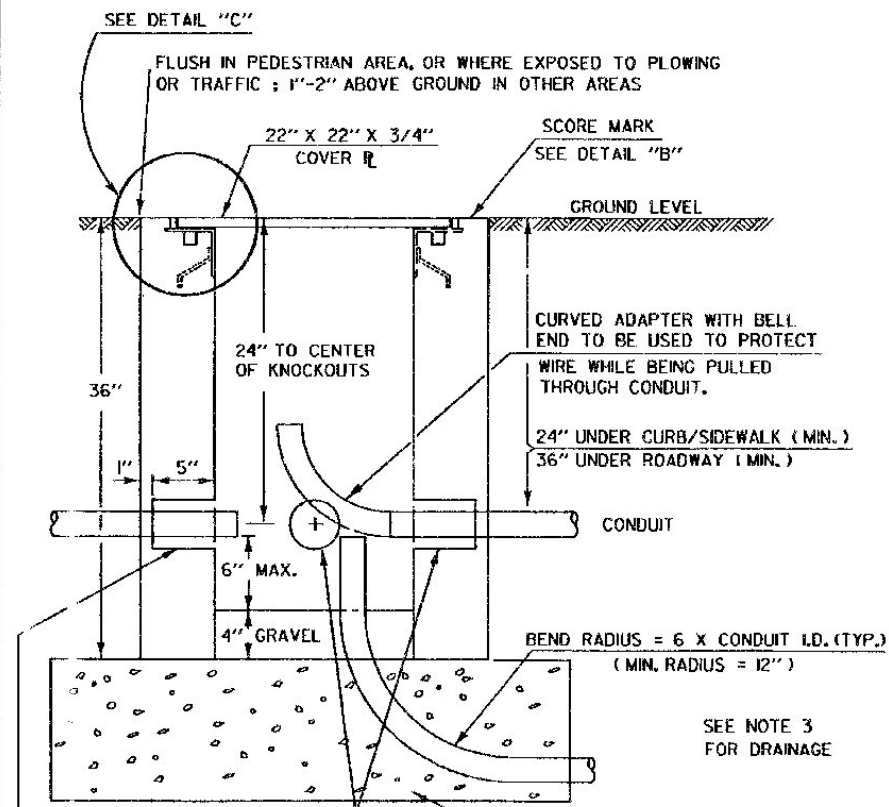

ELEVATION

CONCRETE PULLBOX STANDARD

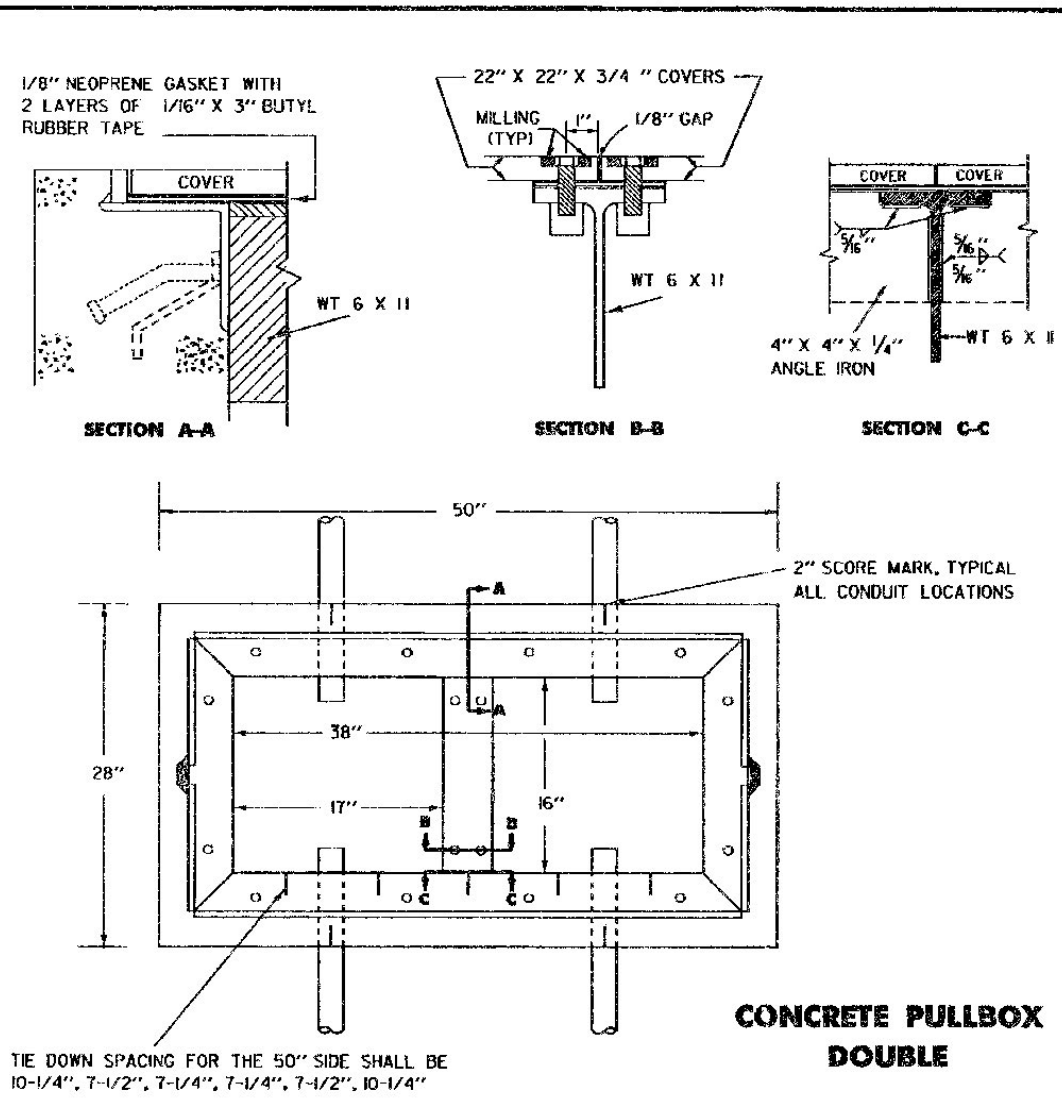

CONCRETE PULLBOX DOUBLE

- PULLBOX & JUNCTION BOX NOTES**
1. ALL PULLBOXES SHALL BE CONSTRUCTED WITH CONCRETE, CLASS B.
 2. CONDUIT SIZE AS SHOWN ON THE PLANS.
 3. EXCAVATION FOR THE UNITS SHALL INCLUDE EXCAVATION OF AN AREA ONE FOOT OUTSIDE THE UNITS AND EXTENDING ONE FOOT BELOW THE FINISH GRADE OF THE BOTTOM OF THE UNITS. ONE FOOT OF GRANULAR MATERIAL SHALL BE PLACED IN THE EXCAVATED AREA AND PROPERLY COMPACTED PRIOR TO INSTALLATION. WHERE NECESSARY AND AT THE DISCRETION OF THE ENGINEER, A DRAINAGE PIPE (MINIMUM 3" PERFORATED PVC) SHALL BE PROVIDED FROM THE UNIT TO THE NEAREST APPROPRIATE OUTLET. DRAINAGE WORK SHALL NOT BE PAID DIRECTLY, BUT WILL BE CONSIDERED PART OF THE PULLBOX OR JUNCTION BOX ITEM.
 4. ALL EXPOSED METAL HARDWARE, INCLUDING PULLBOX COVERS, FRAMES & ANGLES, SHALL BE GALVANIZED OR STAINLESS STEEL.
 5. ALL CONDUIT SHALL ENTER JUNCTION BOXES FROM THE BOTTOM, NOT THROUGH THE SIDE WALL.
 6. CONDUITS SHALL NOT ENTER DOUBLE PULLBOXES, DIRECTLY UNDER THE "T" BAR.
 7. THE PRY SLOT AND THE COVER GAPS SHALL BE FILLED WITH CAULKING JUST PRIOR TO PROJECT COMPLETION.
 8. WHEN INSTALLED ON SLOPES, PULLBOXES AND JUNCTION BOXES SHALL BE TIPPED TO MATCH THE EXISTING SLOPE UP TO A 1 ON 4 SLOPE. ON STEEPER SLOPES, THEY SHALL BE INSTALLED AS ON A 1 ON 4 SLOPE. A SUFFICIENT AMOUNT OF THE EXCAVATED MATERIAL SHALL BE USED TO SHAPE AROUND THE LOW SIDE OF THE BOX SUCH THAT THE MAXIMUM EXPOSURE IS 2". THE MATERIAL SHALL BE TAPERED OVER AN AREA EXTENDING ABOUT 5' FROM THE BOX. IF SUFFICIENT MATERIAL IS NOT AVAILABLE, MATERIAL MEETING THE REQUIREMENTS OF EARTH BORROW (SUBSECTION 703.02) SHALL BE USED. PAYMENT SHALL BE CONSIDERED PART OF THE PULLBOX OR JUNCTION BOX ITEM.
 9. ALL COVERS SHALL BE FLUSH WITH THE BOXES AND FRAMES.
 10. ALL CONDUITS ENTERING A PULLBOX OR JUNCTION BOX SHALL HAVE BUSHINGS TO PROTECT THE CABLES.

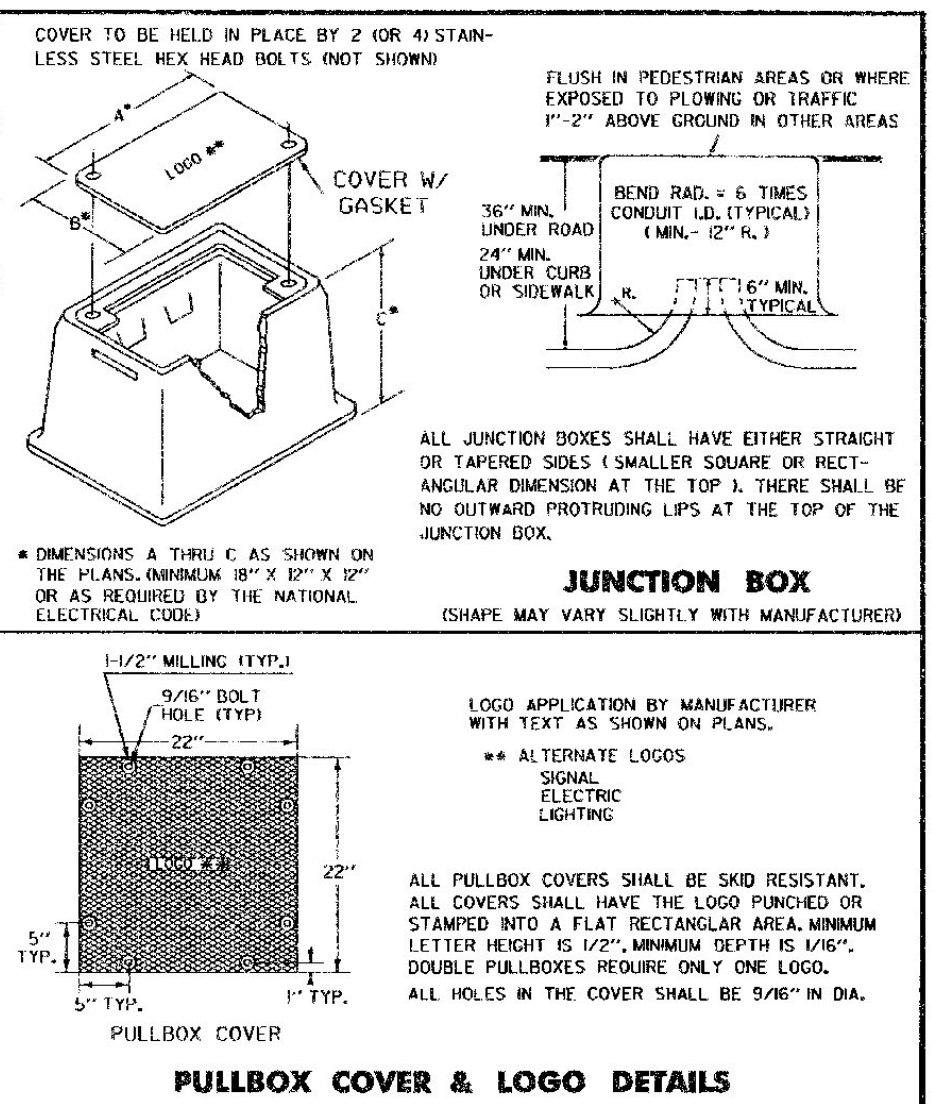
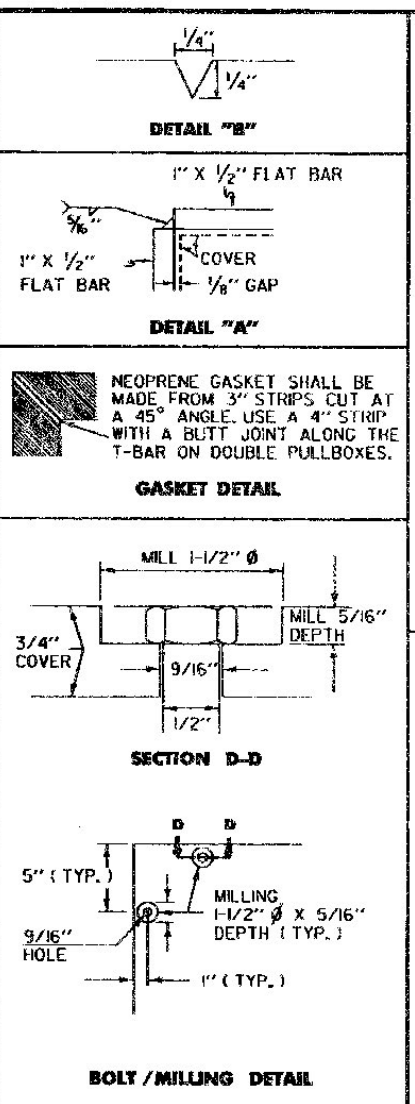

JUNCTION BOX

PULLBOX COVER & LOGO DETAILS

REVISIONS AND CORRECTIONS

SEPT. 10, 1987 - DATE OF ORIGINAL ISSUE
 APRIL 1, 1989 - REVISED COVER DIMENSIONS
 MAY 26, 1989 - FHWA COMMENTS
 NOV. 17, 1993 - MAJOR REVISIONS, STANDARDIZATION OF PULLBOX COVERS
 AUG. 9, 1995 - REVISED NOTE 8, CHANGED LOGO OPTIONS

APPROVED FOR THIS PROJECT AND/OR DESIGN IMPLEMENTATION. FINAL APPROVAL PENDING.

APPROVED

Stephen S. MacArthur
 DIRECTOR OF ENGINEERING

David A. Ross
 TRAFFIC AND SAFETY ENGINEER

PULLBOXES AND JUNCTION BOXES

OTHER STDS. REQUIRED NONE

VERMONT AGENCY OF TRANSPORTATION

STANDARD E-173

/trf/std/std073.dgn - std073.1