

SPAN WIRE MOUNTED TRAFFIC SIGNALS WITH LUMINAIRES

- NOTES**
- 1) ALL SOLID STATE TRAFFIC SIGNAL EQUIPMENT SHALL MEET OR EXCEED ALL REQUIREMENTS OF THE LATEST REVISION OF THE NATIONAL ELECTRICAL MANUFACTURERS ASSOC. (NEMA) AND THE INTERNATIONAL MUNICIPAL SIGNAL ASSOC. (IMSA) STANDARDS FOR TRAFFIC CONTROL SYSTEMS.
 - 2) ALL ELECTRICAL WIRE AND CABLE SHALL BE COPPER. ELECTRICAL SIGNAL CABLE FROM TRAFFIC SIGNAL CONTROLLER TO SIGNAL HEADS SHALL BE COMPOSED OF A.W.G. # 12 (MIN) STRANDED CONDUCTORS, AND SHALL MEET IMSA WIRE AND CABLE SPECIFICATIONS.
 - 3) ALL SIGNAL HEAD CABLES SHALL BE CONTINUOUS FROM THE CONTROLLER TO THE NEAREST SIGNAL HEAD TO WHICH IT APPLIES. THE CABLE SHALL ALSO BE CONTINUOUS FROM THE FIRST SIGNAL HEAD TO ANY ADDITIONAL HEADS WITH TERMINATION IN THE DISCONNECT HANGER.
 - 4) THE PEDESTRIAN SIGNAL HEADS SHALL HAVE AUDIO SIGNALS TO INDICATE ALLOWABLE PEDESTRIAN MOVEMENT FOR THE VISUALLY IMPAIRED DURING THE PEDESTRIAN PHASE. THEY SHALL BE OF THE TYPE NORMALLY USED FOR SUCH AN INSTALLATION AND BE WIRED IN SUCH A WAY AS TO BE EASILY DEACTIVATED. AFTER THE AUDIO SIGNAL HAS BEEN INSTALLED AND FIELD TESTED IT SHALL BE DEACTIVATED, UNLESS NOTED OTHERWISE. PEDESTRIAN PUSH BUTTONS SHALL BE INSTALLED AT EACH END OF EACH CROSSWALK WHERE ACTUATED PEDESTRIAN SIGNALS ARE INSTALLED OR AS SHOWN ON THE PLANS.
 - 5) THE PEDESTRIAN HEADS SHALL HAVE TEXT "WALK", "DON'T WALK", UNLESS OTHERWISE NOTED. THEY SHALL MEET THE LATEST REQUIREMENTS OF THE MANUAL ON UNIFORM TRAFFIC CONTROL DEVICES (MUTCD).
 - 6) WHEN STREET LIGHTS ARE INSTALLED ON A TRAFFIC SIGNAL STRAIN POLE, AND THE STREET LIGHTING ITEM IS NOT PART OF THE CONTRACT, THE LUMINAIRES AND BRACKET ARMS ARE INCLUDED UNDER THE TRAFFIC CONTROL SIGNAL ITEM. THEY SHALL MEET ALL OF THE REQUIREMENTS OF SECTION 679 OF THE CURRENT VERMONT STANDARD SPECIFICATIONS FOR CONSTRUCTION.

- 7) SIGNAL TIMING IS APPROXIMATE AND IS NOT TO BE CONSIDERED FINAL. ALL NECESSARY HARDWARE TO CHANGE THE TIMING SHALL BE ON HAND WHEN THE SIGNALS ARE ACTIVATED. THE RESIDENT ENGINEER SHALL PERFORM CHECKS DURING THE AM AND PM PEAK PERIODS TO INSURE OPTIMUM SETTINGS. IF REQUIRED, APPROPRIATE TIMING CHANGES SHALL BE MADE TO "FINE-TUNE" THE CONTROLLER TO ITS BEST EFFICIENCY PRIOR TO COMPLETION OF THE PROJECT. TIMING CHANGES WILL BE ESTABLISHED BY A REPRESENTATIVE OF THE V.A.O.T. TRAFFIC AND SAFETY DIVISION. TIMING ADJUSTMENTS SHALL BE SUBSIDIARY TO THE TRAFFIC CONTROL SIGNAL ITEM. MINOR TIMING CHANGES MADE TO "FINE-TUNE" THE CONTROLLER WILL NOT EFFECT THE RUNNING OF THE 30 DAY TEST PERIOD.
- 8) THE TRAFFIC SIGNAL STRAIN POLES SHALL BE BACK RAKED BEFORE THE WIRES AND SIGNALS ARE INSTALLED SO THAT THE POLES WILL BE PLUMB WHEN DEAD LOAD DEFLECTION DUE TO SPAN WIRE AND SIGNAL HEADS OCCURS. THE AMOUNT OF BACK RAKE SHALL BE AS SHOWN ON THE PLANS.
- 9) THE SIGNAL SYSTEM SHALL NOT OPERATE WITHOUT THE APPROPRIATE PAVEMENT MARKINGS AND RELATED SIGNING IN PLACE.
- 10) THE SIGNAL HEADS SHALL BE COVERED WITH AN OPAQUE COVERING UNTIL SUCH TIME AS THE SIGNAL SYSTEM IS FUNCTIONAL. AT NO TIME SHOULD THE HEADS BE VIEWED WITHOUT HAVING SOME FORM OF SIGNAL INDICATION, I.E. FLASHING OPERATION OR SEQUENCING AS PER PLAN.
- 11) THE CONFLICT MONITOR SHALL BE CAPABLE OF DETECTING A LACK OF RED SIGNAL AS WELL AS THE GREEN, YELLOW AND WALK SIGNALS AND SHALL BE CAPABLE OF STORING AT LEAST NINE PREVIOUS FAULTS FOR RECALL VIA A DISPLAY SCREEN.
- 12) THE VEHICLE DETECTOR AMPLIFIERS AND PHASE MODULES (WHERE APPROPRIATE) INSIDE THE CONTROLLER CABINET SHALL HAVE LABELS TO INDICATE WHICH PHASE AND MOVEMENT GOES WITH EACH. THE LABELS SHALL BE 1/2" WIDE. THE LOOP DETECTOR LEAD-INS SHALL ALSO BE LABELED AT THE TERMINAL BOARD AS TO WHICH MOVEMENT AND LANE THEY ARE FROM. VEHICLE DETECTOR AMPLIFIERS SHALL BE OF A TYPE THAT FAIL IN THE "ON" POSITION.
- 13) ALL LOAD SWITCH BAYS SHALL BE LABELED ON THE CABINET WALL.
- 14) TEST SWITCHES FOR EACH PHASE SHALL BE PLACED EITHER ON THE CABINET DOOR OR IN A CONVENIENT LOCATION ON THE SIDE WALL.
- 15) ALL DOOR MOUNTED SWITCHES AND BUTTONS SHALL BE PROTECTED FROM ACCIDENTAL BUMPING OR FROM COMING INTO CONTACT WITH OTHER EQUIPMENT WHEN THE DOOR IS CLOSED.
- 16) ALL SIGNALS SHALL BE WIRED SUCH THAT NO MORE THAN TWO THROUGH FACES (NORTH-SOUTH AND/OR EAST-WEST) ARE WIRED INTO ONE LOAD SWITCH EVEN THOUGH TWO APPROACHES ARE GREEN DURING THE SAME PHASE.
- 17) THE CONTRACTOR SHALL PROVIDE A MINIMUM OF TWO COPIES OF THE INSTRUCTION MANUALS FOR THE CONTROLLER, LOOP DETECTORS, CONFLICT MONITORS, AND ANY OTHER EQUIPMENT INCLUDED IN THE CABINET. ONE COPY IS TO BE KEPT IN THE CABINET AND THE OTHER GIVEN TO THE PARTY RESPONSIBLE FOR MAINTENANCE OF THE SIGNAL SYSTEM. ADDITIONAL COPIES TO BE PROVIDED AS CALLED FOR ON THE PLANS.
- 18) FOR PROGRAMMABLE SOLID STATE CONTROLLERS AND MASTERS, COPIES OF THE FINAL PROGRAM LISTINGS SHALL BE PROVIDED AND DISTRIBUTED AS DETAILED IN NOTE 17.
- 19) PHASING CHANGES, IF REQUESTED AND FEASIBLE, SHALL BE CONSIDERED AS PART OF THE CONTRACT. EXTRA COMPENSATION FOR THE CHANGES MAY BE AUTHORIZED FOLLOWING APPROVAL OF THE ESTIMATE.
- 20) THE NEW TRAFFIC SIGNALS SHALL BE ACTIVATED ONLY UPON THE APPROVAL OF THE ENGINEER AND AFTER FLASHING FOR A MINIMUM OF 48 HOURS.
- 21) IF THE PROJECT INVOLVES REPLACING OR IMPROVING AN EXISTING TRAFFIC SIGNAL, TRAFFIC SHALL BE CONTROLLED BY A UNIFORMED TRAFFIC OFFICER AT ANY TIME THE SIGNAL IS NOT SEQUENCING PER PLAN OR OPERATING ON FLASH. THE SWITCH FROM THE OLD TO THE NEW SIGNAL SHALL BE DONE DURING OFF-PEAK TRAFFIC AND IN SUCH A WAY AS TO MINIMIZE DOWN TIME.
- 22) REMOVAL OF EXISTING SIGNAL EQUIPMENT, INCLUDING FOOTINGS AND BACKFILL OF THE HOLES, SHALL BE SUBSIDIARY TO THE TRAFFIC CONTROL SIGNAL ITEM.
- 23) TRAFFIC & PEDESTRIAN SIGNALS MOUNTED ON THE SIDE OF THE SIGNAL POLES MAY BE ATTACHED BY METHODS OTHER THAN THOSE SHOWN. SHOP DRAWINGS FOR THE ALTERNATE MOUNTING HARDWARE MUST BE SUBMITTED TO THE TRAFFIC DESIGN SECTION OF THE VAOT VIA THE RESIDENT ENGINEER FOR APPROVAL PRIOR TO CONSTRUCTION.
- 24) ALL RIGIDLY MOUNTED TRAFFIC AND PEDESTRIAN SIGNAL HEADS (POST TOP, SIDE OR ARM MOUNTED) SHALL BE HEAVY DUTY ALUMINUM, UNLESS OTHERWISE NOTED ON THE PLANS.
- 25) WHEN (FREE SWINGING) OPTICALLY PROGRAMMABLE SIGNAL HEADS ARE REQUIRED, THEY SHALL NOT BE INSTALLED ON THE SAME HANGER ASSEMBLY AS LIGHTER WEIGHT HEADS, UNLESS OTHERWISE NOTED ON THE PLANS. WHEN TWO HANGER ASSEMBLIES ARE INSTALLED CLOSE TOGETHER, THE BOTTOM OF THE SIGNALS SHALL BE CONNECTED BY A FLAT ARM ASSEMBLY TO PREVENT THE HEADS FROM HITTING EACH OTHER.
- 26) WHEN MASKING OF OPTICALLY PROGRAMMABLE SIGNAL HEADS IS REQUIRED, THE HEADS SHALL BE RIGIDLY MOUNTED OR TETHERED.

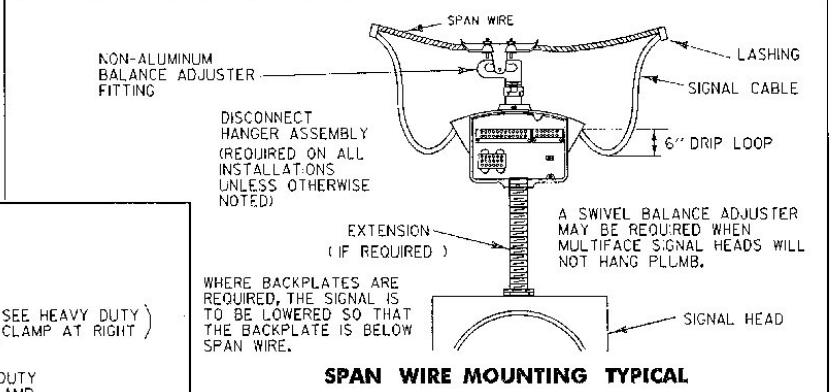

SPAN WIRE MOUNTING TYPICAL

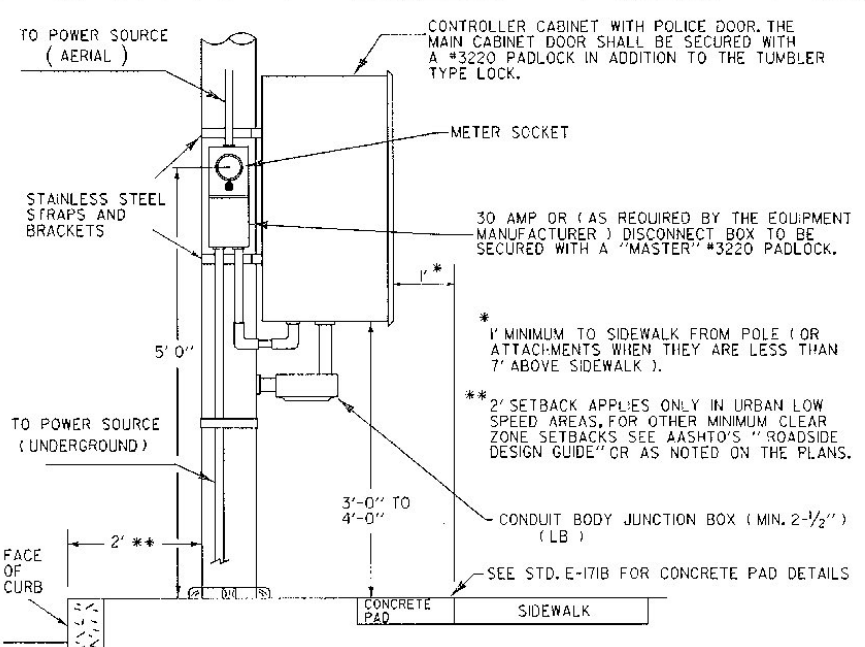

POLE MOUNTED CONTROLLER CABINET INSTALLATION TYPICAL

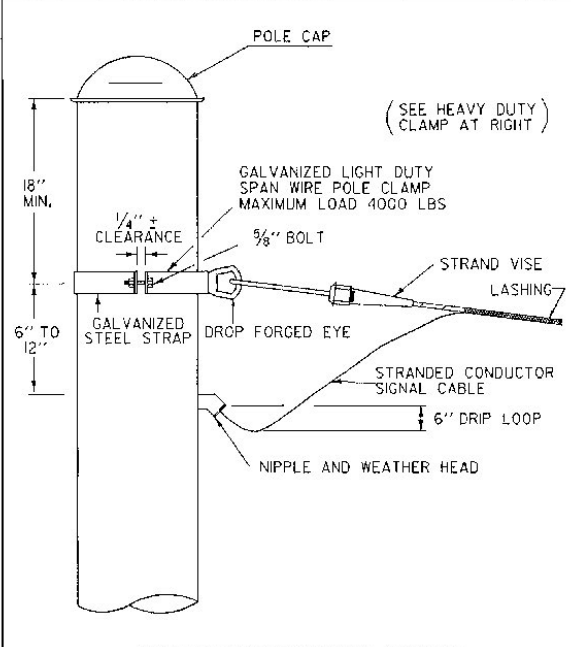

CABLE INSTALLATION TYPICAL WITH SPAN WIRE POLE CLAMP (LIGHT DUTY GALVANIZED)

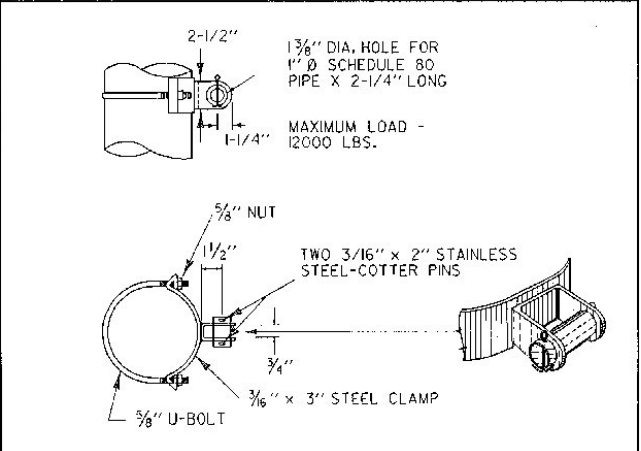

SPAN WIRE CLAMP (HEAVY DUTY GALVANIZED)

OTHER STDS. E - 171B, E - 175 REQUIRED

REVISIONS AND CORRECTIONS

JUNE 21, 1989 - DATE OF ORIGINAL ISSUE
MAY 14, 1990 - FHWA COMMENTS
NOV. 17, 1993 - FHWA COMMENTS, NOTE REVISIONS AND POLE MOUNTING DETAIL MOVED TO E-171B

APPROVED

Carolyn J. MacArthur
DIRECTOR OF ENGINEERING

Francis J. Ross
TRAFFIC AND SAFETY ENGINEER

**TRAFFIC CONTROL SIGNALS
GENERAL NOTES & DETAILS**

VERMONT AGENCY OF TRANSPORTATION

STANDARD E-171A