

GUARDRAIL DEFLECTION CHART

(PER AASHTO - ROADSIDE DESIGN GUIDE - 1988)

TYPE	GR POST SPACING	DEFLECTION
THREE CABLE W/STEEL POSTS	16' - 0"	12'
W/WOODEN POSTS	12' - 6"	12'
W-BEAM W/WEAK POST	12' - 6"	7'
W/STRONG POST	6' - 3"	3'
BOX BEAM	6' - 0"	5'
THREE BEAM W/WEAK POST	12' - 6"	4'
W/STRONG POST	6' - 3"	2'
TWO-RAIL ELLIPTICAL ALUMINUM		2'

THIS CHART LISTS THE THEORETICAL DEFLECTION DISTANCE UPON IMPACT OF VARIOUS GUARDRAIL WITH DIFFERENT TYPES AND SPACING OF POSTS.

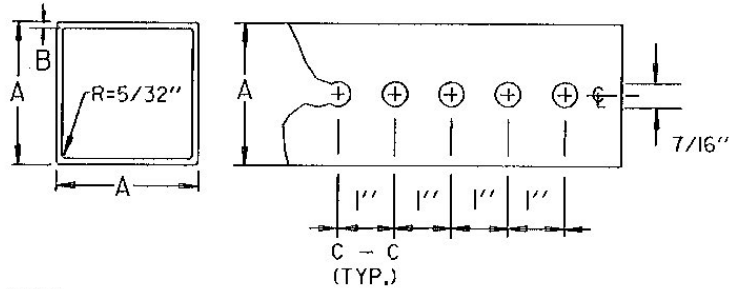

NOTE :

THE POSTS SHALL BE CAREFULLY FORMED OF STEEL WITH A MINIMUM YIELD OF 55,000 PSI, INTO A SIZE AND SHAPE WITH CORNERS INDUCTION WELDED IN SUCH A MANNER THAT NEITHER FLASH NOR WELD SHALL INTERFERE WITH THE TELESCOPING PROPERTIES, NOR DAMAGE THE GALVANIZING.

• THE WALL THICKNESS TOLERANCES SHALL BE +.007 AND -.011 FOR THE 12 GAUGE.

DIMENSION DETAILS AND POST SELECTION CHART

POST SELECTION CHART								
SIGN AREA (FT ²) X H (FT) ≤ SV (SELECTION VALUE)								
POST SIZE LBS/FT.	DIMENSIONS			SECTION MODULUS IN ³	ONE POST S _v	TWO POST S _v	THREE POST S _v	NUMBER PERMITTED IN 8' PATH
	A	*B	GAUGE					
2.30	1-3/4"	.105	12	0.265	85	170	255	TWO
2.65	2"	.105	12	0.372	119	239	358	TWO
3.35	2-1/2"	.105	12	0.642	206	412	616	ONE

DESIGN CRITERIA:

WIND SPEED = 60 MPH (10 -YEAR MEAN RECURRENCE INTERVAL)
 WIND PRESSURE = 13 PSF
 STEEL MINIMUM YIELD = 55,000 PSI
 ALLOWABLE STRESS = (1.4) 0.60 FY

REVISIONS AND CORRECTIONS

APRIL 27, 1994 - DATE OF ORIGINAL ISSUE

APPROVED

Stephen D. MacArthur
 DIRECTOR OF ENGINEERING

David A. Ross
 TRAFFIC AND SAFETY ENGINEER

APPROVED FOR THIS PROJECT
 AND/OR DESIGN IMPLEMENTATION
 FHWA FINAL APPROVAL PENDING.

TOP VIEW OF ANCHOR, POST AND BOLT

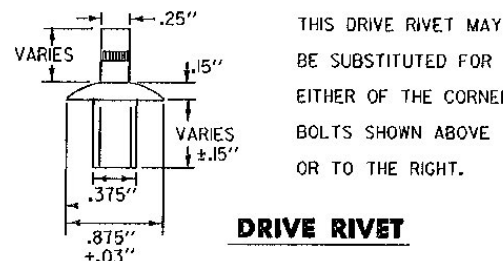
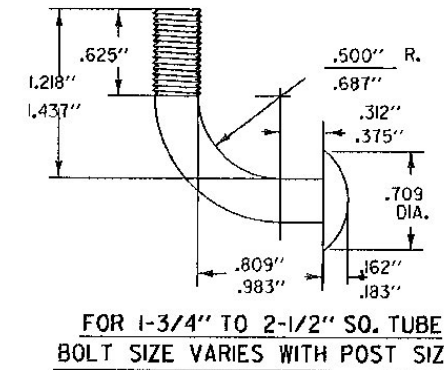
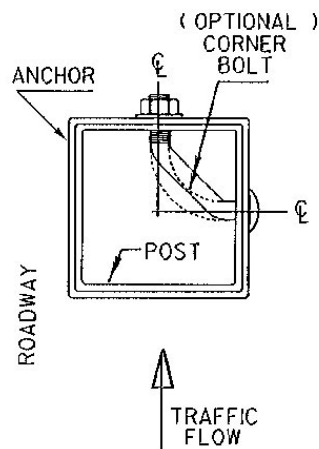

OPTIONAL CORNER BOLT DETAILS

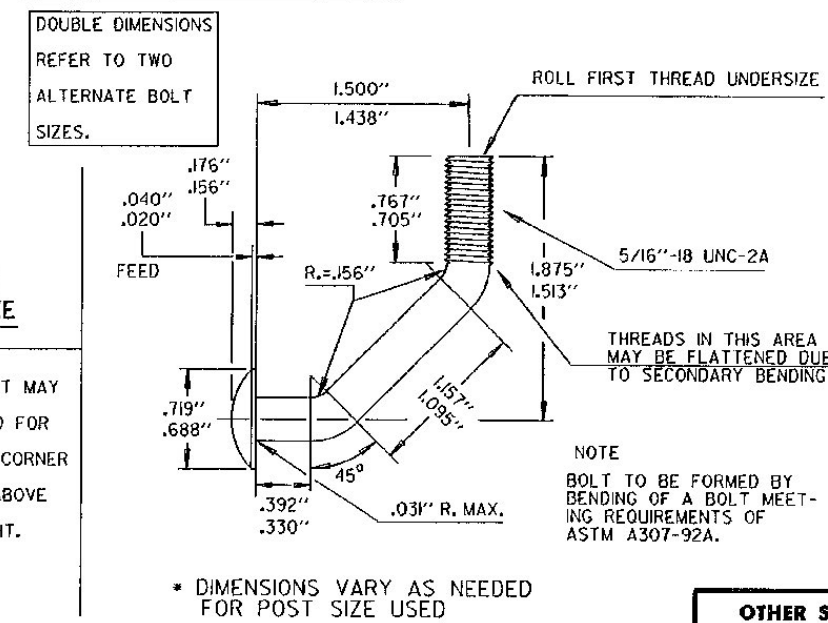

MULTI-POST INSTALLATIONS

WHEN SIGN POSTS ARE INSTALLED WITH A POST SPACING OF LESS THAN 8 FEET, POST SIZES MUST BE SELECTED TO INSURE THAT WHEN ACTING TOGETHER THE POSTS DO NOT CREATE A HAZARD.

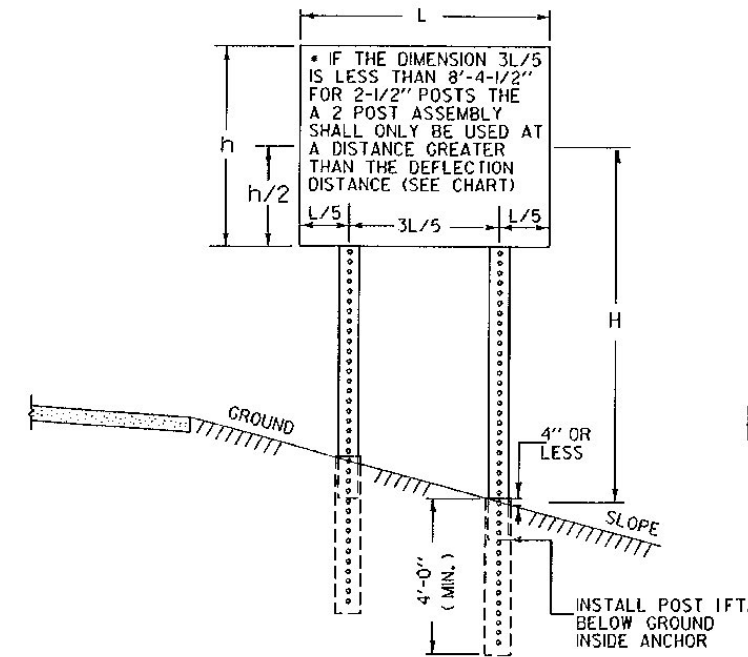

POST SPACING DETAILS

GENERAL NOTES

CONSTRUCTION METHODS - POSTS MAY BE DRIVEN OR SET IN A DUG HOLE AND BACKFILLED. IF DRIVEN, A DRIVING CAP SHALL BE USED. THE DUG HOLE INSTALLATION SHALL BE USED IN AREAS OF POOR SOIL CONDITIONS OR AS DIRECTED BY THE RESIDENT ENGINEER. BACKFILL SHALL BE COMPACTED AS DIRECTED BY THE RESIDENT ENGINEER.

SIGN CLEARANCES - HORIZONTAL AND VERTICAL SIGN CLEARANCES SHALL BE SHOWN ON THE PLANS OR THE APPROPRIATE STD. SHEETS.

SINGLE POST INSTALLATIONS SHALL BE LIMITED TO A SIGN AREA OF 20 SQ. FT. OR LESS

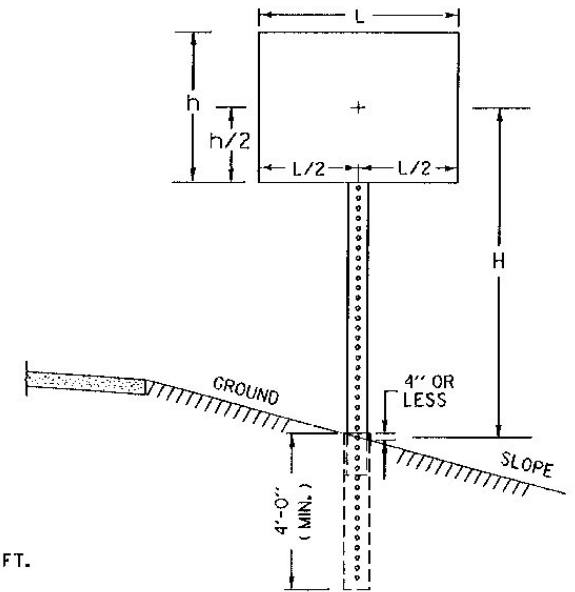

CONNECTION DETAIL

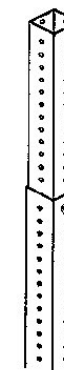

POST IS TO BE INSERTED INTO ANCHOR ONE FOOT BELOW GROUND LEVEL. ANCHOR IS TO BE 4'-0" MINIMUM LENGTH WITH NO MORE THAN 4" ABOVE GROUND. ANCHOR IS ONE SIZE (1/4") GREATER THAN THE POST AND ALL ANCHORS ARE TO BE 12 GAGE EXCEPT ANCHORS FOR 2-1/2" POSTS ARE TO BE 7 GAGE. CONNECTION IS TO BE MADE USING THE BOLT PROVIDED WITH THE SIGN SYSTEM (SEE DETAILS LEFT). AT THE TOP HOLE IN THE ANCHOR (APPROXIMATELY 3-1/2" ABOVE GROUND), THREE INCH ANCHORS WHICH DO NOT HAVE HOLES ON 1" CENTERS WILL REQUIRE DRILLING OF 7/16" HOLES FOR CONNECTIONS.

(SEE DETAIL LEFT FOR BOLT PLACEMENT)

OTHER STDS. REQUIRED E-120, E-160 SIGN POST DEGN. GUIDE

PRELIMINARY SQUARE STEEL SIGN POST



STANDARD E-164