

**DETAILS OF MULTI-DIRECTIONAL SLIP BASE**

TABLE A

DIMENSIONS NOMINAL PIPE SIZES	BOLT SIZE & TORQUE	WELD SIZE	t	Y	A	B	C	D	E	F	G	K	L	M	U	N
3" DIA.	5/8"Øx3/4"	3/8"	5/8"	7"	7"	3 1/2"	1 3/4"	1 1/4"	3"	2 5/8"	2"	10 3/8"	9"	1/2"	1/2"	6"
3 1/2" DIA.	T=450" LBS.	3/8"	5/8"	7"	7"	3 1/2"	1 3/4"	1 1/4"	3"	2 5/8"	2"	10 3/8"	9"	1/2"	1/2"	6"
4" DIA.	3/4"Øx3 3/4"	3/8"	7/8"	8 3/8"	9"	4 1/2"	2 1/4"	1 1/2"	3 7/8"	2 7/8"	2 1/2"	13"	11 1/4"	5/8"	1/2"	7 1/2"
5" DIA.	T=750" LBS.	3/8"	7/8"	8 3/8"	9"	4 1/2"	2 1/4"	1 1/2"	3 7/8"	2 7/8"	2 1/2"	13"	11 1/4"	5/8"	1/2"	7 1/2"

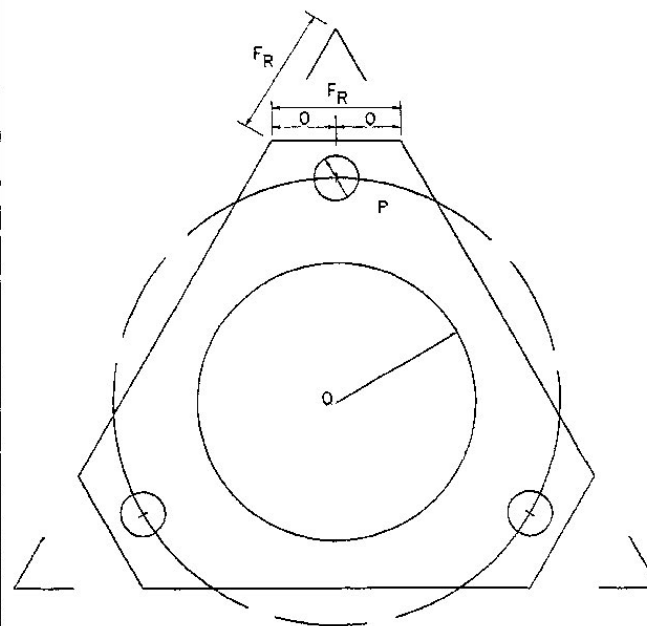

**BOLT RETAINER PLATE**

28 GAUGE (0.0187") GALVANIZED STEEL

BOLT RETAINER PLATE SIMILAR IN DETAIL TO THE BASE PLATES WITH THE FOLLOWING EXCEPTIONS

DIMENSIONS NOMINAL PIPE SIZES	FR	O	P	Q
3" DIA.	2 1/8"	1 1/8"	1 1/8"	2 1/2"
3 1/2" DIA.	2 1/8"	1 1/8"	1 1/8"	2 1/2"
4" DIA.	2 5/8"	1 5/8"	1 5/8"	2 7/8"
5" DIA.	2 5/8"	1 5/8"	1 5/8"	2 7/8"

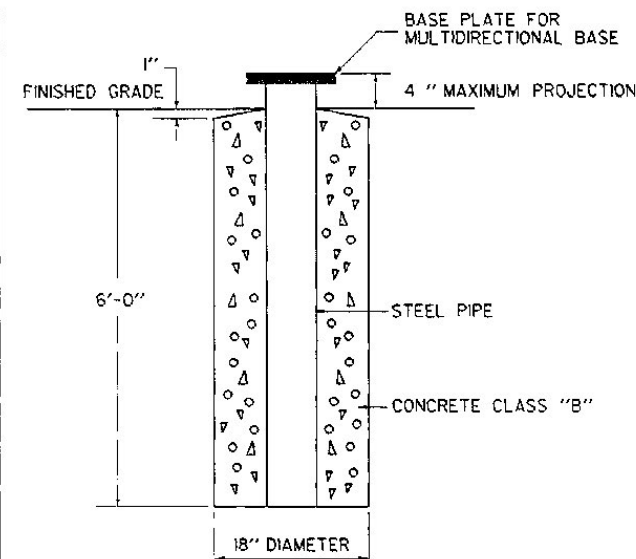

**FOUNDATION DETAIL**

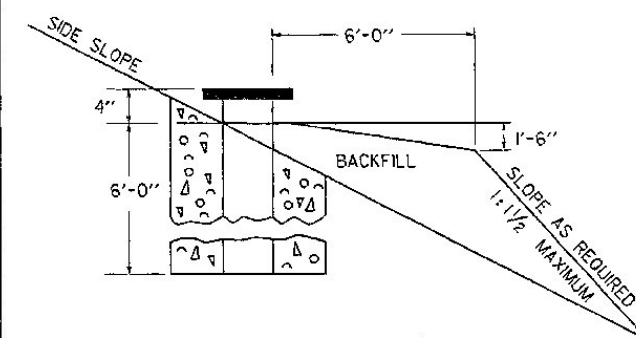

**SIDE SLOPE TREATMENT**

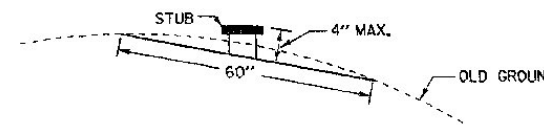

SEE GENERAL NOTE # 4.

**GENERAL NOTES**

1. THE STEEL PIPE SHALL BE MANUFACTURED TO ASTM A501 OR ASTM A-53, TYPES E OR S, GRADE B AND SHALL BE GALVANIZED AS PER ASTM A-153.
2. THE MATERIAL FOR THE MULTIDIRECTIONAL SLIP BASE ASSEMBLY SHALL CONFORM TO AASHTO M-270, GRADE 36 STEEL, AND BE GALVANIZED AS PER ASTM A-153.
3. THE BOLTS, NUTS AND CIRCULAR WASHERS SHALL CONFORM TO ASTM SECTION 15 A-325, "HIGH STRENGTH CARBON STEEL BOLTS FOR STRUCTURAL STEEL JOINTS". ALL BOLTS, NUTS, AND WASHERS SHALL BE GALVANIZED AS PER ASTM A-123.
4. ALL DIMENSIONS REFERRING TO STUB HEIGHT IN THE VARIOUS TABLES AND FOUNDATION DETAILS SHALL BE ADJUSTED AS REQUIRED TO RESULT IN A TOTAL STUB HEIGHT WHICH IS NOT MORE THAN FOUR INCHES ABOVE A 60-INCH CHORD ALIGNED RADIALLY TO THE CENTERLINE OF THE HIGHWAY AND CONNECTING ANY POINT, WITHIN THE LENGTH OF THE CHORD, ON THE GROUND SURFACE ON ONE SIDE OF THE SUPPORT TO A POINT ON THE GROUND SURFACE ON THE OTHER SIDE.

**CONSTRUCTION METHOD**

HOLES FOR POST FOOTINGS MAY BE AUGERED OR DUG, IF THE MATERIAL IS FIRM AND IF ALL DISTURBED SOIL AROUND THE CIRCUMFERENCE OF THE AUGERED HOLE IS REMOVED, THE HOLES MAY BE LEFT WITH EARTH SIDES. IF NOT, A SUITABLE FORM APPROVED BY THE ENGINEER SHALL BE USED. CORRUGATED METAL CULVERT PIPE OR PAPER FORMS, MANUFACTURED FOR USE AS CONCRETE COLUMN FORMS, WILL BE ACCEPTABLE. THE STUB SHALL BE EXTENDED TO THE BOTTOM OF THE HOLE AND SET ON A CONCRETE PAD FOOTING TO SUPPORT THE POST SO THE POST SHALL BE HELD SECURELY IN PLACE AT THE BOTTOM. THIS MAY BE DONE BY EMBEDDING THE POST AND CONCRETE BLOCK FOOTING IN WET CONCRETE, AND ALLOWING TO SET WITH THE POST SECURED IN POSITION; PLUMBED AND PROPERLY BRACED. THE REMAINDER OF THE FOOTING MAY THEN BE POURED. THE TIME BETWEEN POURS FOR THE CURING OF THE CONCRETE SHALL BE AS DETERMINED BY THE ENGINEER. THE FORM SHALL BE LEFT IN PLACE AND THE HOLE BACKFILLED AND COMPACTED AS DIRECTED BY THE ENGINEER. NO PART OF THE FORM SHALL SHOW ABOVE THE GROUND LINE WHEN THE WORK IS COMPLETED.

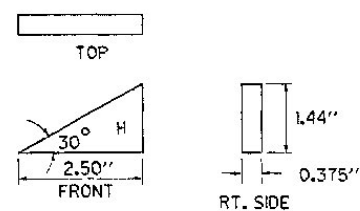
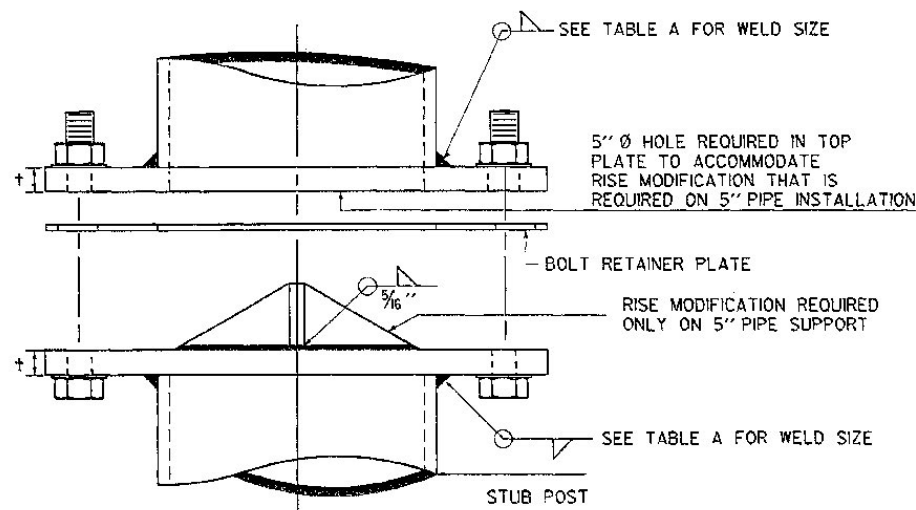

**DETAIL "H"**

3 REQUIRED MOUNTED 120° APART  
RISE MODIFICATION REQUIRED ONLY FOR 5" PIPE SUPPORT

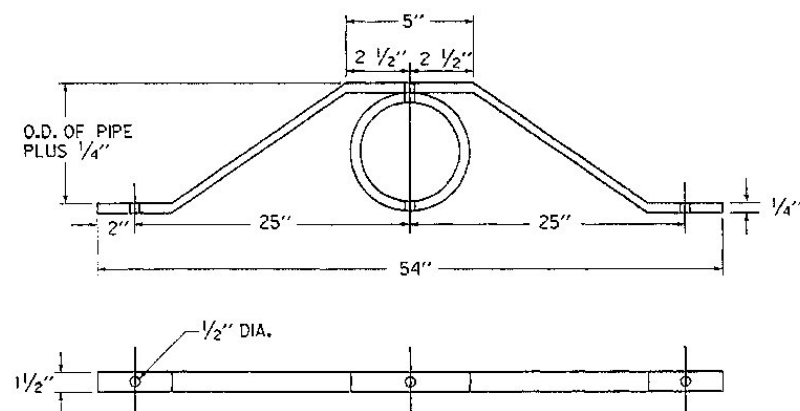

**SIGN SUPPORT BRACE**

(REQUIRED WHEN INSTALLING 3 ASSEMBLY FRAME AS SHOWN ON STANDARD E-123)

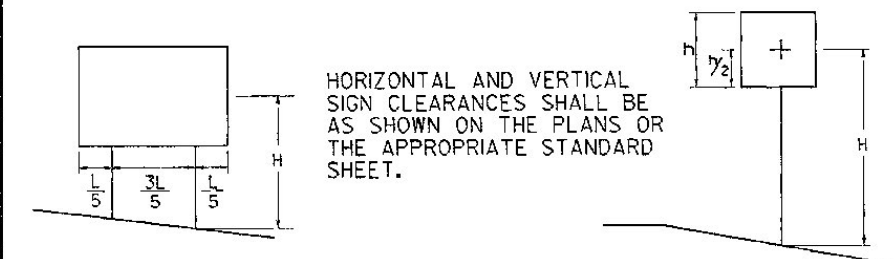

HORIZONTAL AND VERTICAL SIGN CLEARANCES SHALL BE AS SHOWN ON THE PLANS OR THE APPROPRIATE STANDARD SHEET.

**POST SELECTION CHART DETAIL**

SIGN AREA (FT <sup>2</sup> ) x H (FT) ≤ SV (SELECTION VALUE)			
POST DIA. INCHS	WEIGHT LB/FT	SV	DESIGN CRITERIA
3	7.6	265	WIND SPEED = 60 MPH (10-YEAR MEAN RECURRENCE INTERVAL) WIND PRESSURE = 13 PSF STEEL MIN YIELD F <sub>y</sub> = 36,000 PSI ALLOWABLE STRESS = (1.4) 0.60 F <sub>y</sub>
3 1/2	9.0	368	
4	10.8	494	
5	14.6	839	

**REVISIONS AND CORRECTIONS**

OCT 21, 1992 - REVISED NOTES AND DIMENSIONS AND TITLE BLOCK

APPROVED:

SEPT. 10, 1987  
DATE

*Stephen L. MacArthur*  
DIRECTOR OF ENGINEERING

*David A. Ross*  
TRAFFIC AND SAFETY ENGINEER

**TUBULAR STEEL SIGN POST**



**STANDARD E-163**