

DETAILS OF MULTI-DIRECTIONAL SLIP BASE

TABLE A

DIMENSIONS NOMINAL PIPE SIZES	BOLT SIZE & TORQUE	WELD SIZE	t	Y	A	B	C	D	E	F	G	K	L	M	U	N
3" DIA.	5/8" x 3/4"	3/8"	5/8"	7"	7"	3 1/2"	1 3/4"	1 1/4"	3"	2 5/8"	2"	10 3/8"	9"	1/2"	1/2"	6"
3 1/2" DIA.	T=450" LBS.															
4" DIA.	3/4" x 3/4"	7/16"	3/8"	8 3/8"	9"	4 1/2"	2 1/4"	1 1/2"	3 3/8"	2 7/8"	2 1/2"	13"	11 1/4"	5/8"	1/2"	7 1/2"
5" DIA.	T=750" LBS.															

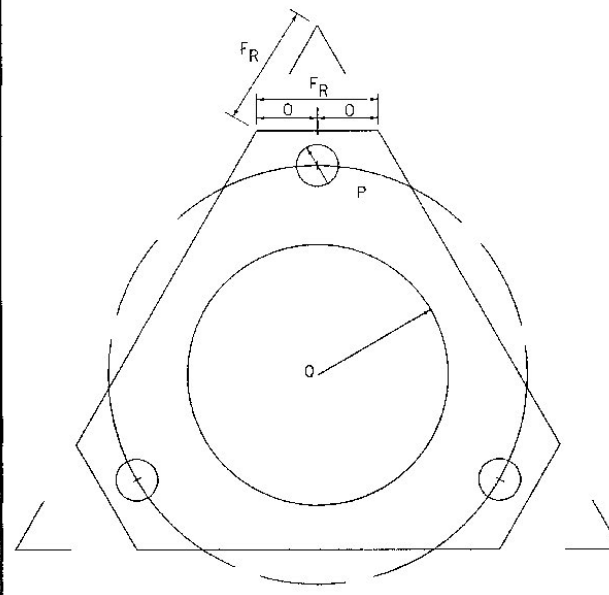

BOLT RETAINER PLATE

28 GAUGE (0.0187") GALVANIZED STEEL

BOLT RETAINER PLATE SIMILAR IN DETAIL TO THE BASE PLATES WITH THE FOLLOWING EXCEPTIONS

DIMENSIONS NOMINAL PIPE SIZES	FR	O	P	Q
3" DIA.	2 1/8"	1 1/16"	1 1/8"	2 1/2"
3 1/2" DIA.				
4" DIA.	2 5/8"	1 5/8"	1 3/8"	2 7/8"
5" DIA.				

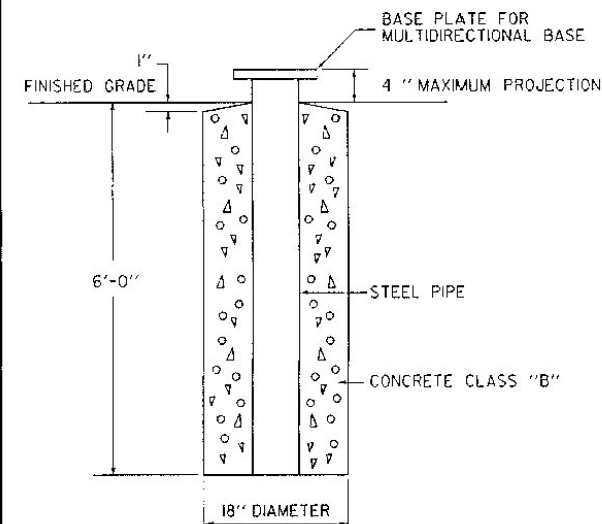

FOUNDATION DETAIL

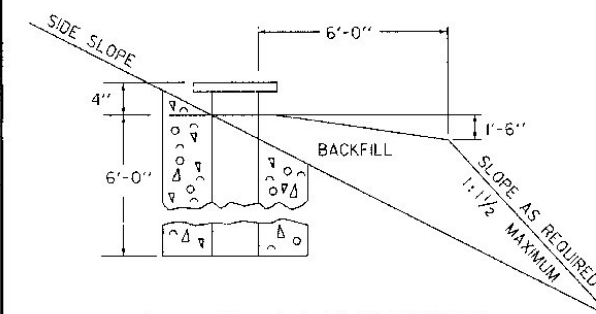

SIDE SLOPE TREATMENT

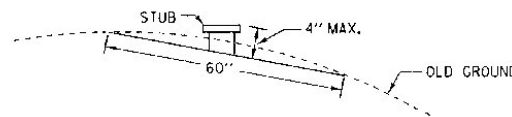

SEE GENERAL NOTE # 4.

- GENERAL NOTES**
- THE STEEL PIPE SHALL BE MANUFACTURED TO ASTM A501 OR ASTM A-53, TYPES E OR S, GRADE B AND SHALL BE GALVANIZED AS PER ASTM A-153.
 - THE MATERIAL FOR THE MULTIDIRECTIONAL SLIP BASE ASSEMBLY SHALL CONFORM TO AASHTO M-270, GRADE 36 STEEL, AND BE GALVANIZED AS PER ASTM A-153.
 - THE BOLTS, NUTS AND CIRCULAR WASHERS SHALL CONFORM TO ASTM SECTION 15 A-325, "HIGH STRENGTH CARBON STEEL BOLTS FOR STRUCTURAL STEEL JOINTS". ALL BOLTS, NUTS, AND WASHERS SHALL BE GALVANIZED AS PER ASTM A-123.
 - ALL DIMENSIONS REFERRING TO STUB HEIGHT IN THE VARIOUS TABLES AND FOUNDATION DETAILS SHALL BE ADJUSTED AS REQUIRED TO RESULT IN A TOTAL STUB HEIGHT WHICH IS NOT MORE THAN FOUR INCHES ABOVE A 60-INCH CHORD ALIGNED RADIALLY TO THE CENTERLINE OF THE HIGHWAY AND CONNECTING ANY POINT, WITHIN THE LENGTH OF THE CHORD, ON THE GROUND SURFACE ON ONE SIDE OF THE SUPPORT TO A POINT ON THE GROUND SURFACE ON THE OTHER SIDE.

CONSTRUCTION METHOD

HOLES FOR POST FOOTINGS MAY BE AUGERED OR DUG, IF THE MATERIAL IS FIRM AND IF ALL DISTURBED SOIL AROUND THE CIRCUMFERENCE OF THE AUGERED HOLE IS REMOVED, THE HOLES MAY BE LEFT WITH EARTH SIDING. IF NOT, A SUITABLE FORM APPROVED BY THE ENGINEER SHALL BE USED. CORRUGATED METAL CULVERT PIPE OR PAPER FORMS, MANUFACTURED FOR USE AS CONCRETE COLUMN FORMS, WILL BE ACCEPTABLE. THE STUB SHALL BE EXTENDED TO THE BOTTOM OF THE HOLE AND SET ON A CONCRETE PAD FOOTING TO SUPPORT THE POST SO THE POST SHALL BE HELD SECURELY IN PLACE AT THE BOTTOM. THIS MAY BE DONE BY EMBEDDING THE POST AND CONCRETE BLOCK FOOTING IN WET CONCRETE, AND ALLOWING TO SET WITH THE POST SECURED IN POSITION, PLUMBED AND PROPERLY BRACED. THE REMAINDER OF THE FOOTING MAY THEN BE POURED. THE TIME BETWEEN POURS FOR THE CURING OF THE CONCRETE SHALL BE AS DETERMINED BY THE ENGINEER. THE FORM SHALL BE LEFT IN PLACE AND THE HOLE BACKFILLED AND COMPACTED AS DIRECTED BY THE ENGINEER. NO PART OF THE FORM SHALL SHOW ABOVE THE GROUND LINE WHEN THE WORK IS COMPLETED.

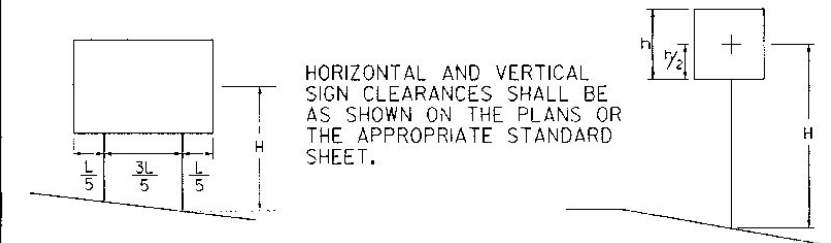

HORIZONTAL AND VERTICAL SIGN CLEARANCES SHALL BE AS SHOWN ON THE PLANS OR THE APPROPRIATE STANDARD SHEET.

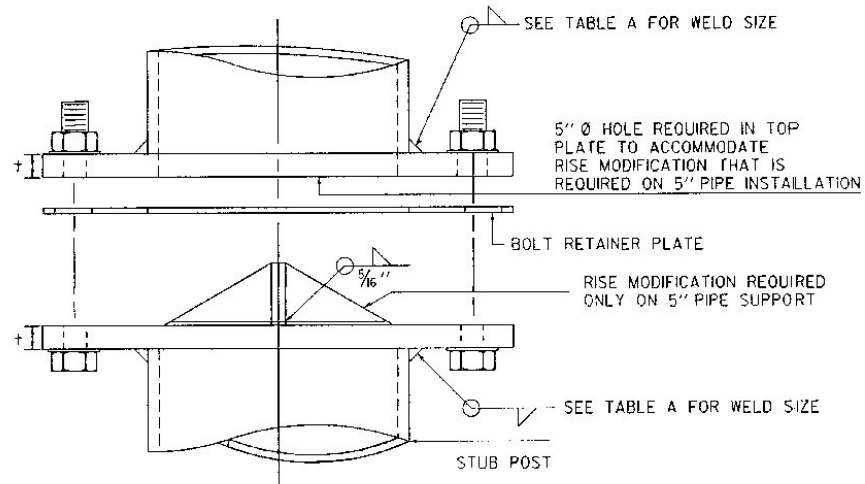

SEE TABLE A FOR WELD SIZE
5" Ø HOLE REQUIRED IN TOP PLATE TO ACCOMMODATE RISE MODIFICATION THAT IS REQUIRED ON 5" PIPE INSTALLATION
BOLT RETAINER PLATE
RISE MODIFICATION REQUIRED ONLY ON 5" PIPE SUPPORT
SEE TABLE A FOR WELD SIZE
STUB POST

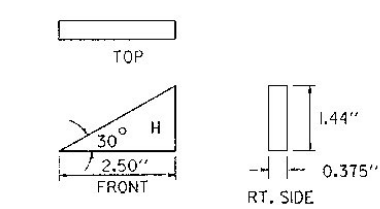

DETAIL "H"
3 REQUIRED MOUNTED 120° APART
RISE MODIFICATION REQUIRED ONLY FOR 5" PIPE SUPPORT

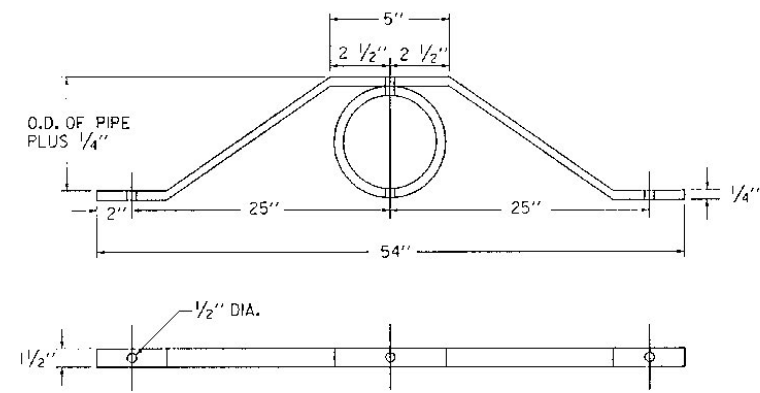

SIGN SUPPORT BRACE
(REQUIRED WHEN INSTALLING 3 ASSEMBLY FRAME AS SHOWN ON STANDARD E-123)

POST SELECTION CHART DETAIL

POST SELECTION CHART

SIGN AREA (FT ²) x H (FT) ≤ SV (SELECTION VALUE)			DESIGN CRITERIA
POST DIA. INCHES	WEIGHT LB/FT	Sv	
3	7.6	265	WIND SPEED = 60 MPH (10-YEAR MEAN RECURRENCE INTERVAL) WIND PRESSURE = 13 PSF STEEL MIN YIELD Fy = 36,000 PSI ALLOWABLE STRESS = (1.4) 0.60 Fy
3 1/2	9.0	368	
4	10.8	494	
5	14.6	839	

OTHER STDS. REQUIRED:

REVISIONS AND CORRECTIONS
SEPT. 26, 1987 - DATE OF ORIGINAL ISS. E
AUG. 18, 1995 - REVISED TITLE BLOCK

APPROVED
Edward P. MacArthur
DIRECTOR OF ENGINEERING
Dale A. Ross
TRAFFIC AND SAFETY ENGINEER

APPROVED FOR THIS PROJECT AND/OR DESIGN IMPLEMENTATION. FHWA FINAL APPROVAL PENDING.

TUBULAR STEEL SIGN POST

/traf/std/stdel63.dgn : stdel63.i

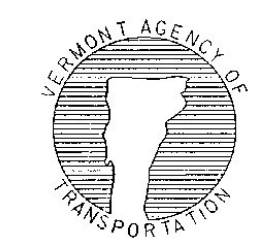

STANDARD E-163