

CAST ALUMINUM CAP FOR SIGN POSTS

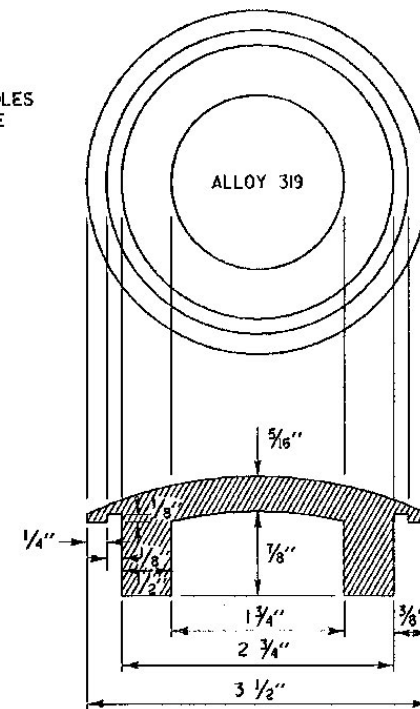

DIMENSIONS SHOWN ARE FOR 3" O.D., 2 3/4" I.D. + COMMERCIAL TOLERANCES. CAPS DESIGNED FOR DRIVE FIT. DIMENSIONS ARE PROPORTIONAL FOR LARGER DIAMETER TUBING.

POST DIAMETER	WALL THICKNESS	WEIGHT PER FT.
3" ROUND	3/16"	1.9 LBS
4" ROUND	3/16"	2.6 LBS
3" SQUARE	3/16"	2.5 LBS

TUBULAR ALUMINUM POST

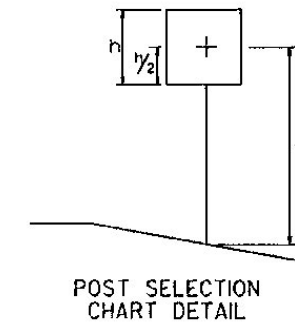

POST SELECTION CHART DETAIL

POST SELECTION CHART		
SIGN AREA (FT. ²) × H (FT.) × SV (SELECTION VALUE)		
POST SIZE	Sv (FT. ³)	DESIGN CRITERIA
3" DIA.	225	WIND VELOCITY = 60 MPH (10 YEAR MEAN RECURRENCE INTERVAL) WIND PRESSURE = 12 PSF, ALUMINUM F _y = 21,000 PSI, ALLOWABLE STRESS = 1.4 (21,000) PSI
4" DIA. (MODIFIED)	276	
3" SQUARE TUBE*	307	
4" DIA.	418	

*USE ON SINGLE POST INSTALLATIONS ONLY

POSTS THE POSTS FOR THESE INSTALLATIONS SHALL BE EXTRUDED TUBULAR POSTS OF ALUMINUM ALLOY 6061-T6.

HARDWARE THE ASSEMBLY HARDWARE USED TO FASTEN A SIGN TO THE POSTS SHALL BE ALUMINUM OR STAINLESS STEEL OF A STANDARD COMMERCIAL DESIGN APPROVED BY THE DEPARTMENT.

ANCHORS USE TWO (2) PIECES OF 2" × 12" ROUGH PLANK, PLANKS, UNLESS OTHERWISE NOTED, SHALL CONFORM TO "STANDARD SPECIFICATIONS FOR CONSTRUCTION" SECTION 728.02

ERECTION ALL POSTS SHALL BE PLUMB AND LOCATED AS SPECIFIED BY DRAWINGS OR BY THE ENGINEER IN THE FIELD. LOCKNUTS ON 3/8" #16 ALUMINUM POST BOLT CLIPS SHALL BE TORQUED TO 225 INCH POUNDS USING DRY, CLEAN, UNLUBRICATED THREADS. WHERE ALUMINUM SURFACES ARE TO BE PLACED IN CONTACT WITH WOOD, THEY SHALL BE GIVEN A THICK COAT OF AN ALKALI-RESISTANT BITUMINOUS PAINT MEETING THE REQUIREMENTS OF MILITARY SPECIFICATION MIL-P-6883, WHICH SHALL BE DRY BEFORE INSTALLATION.

THE HOLE SHALL BE CAREFULLY DUG AND THE POST SET TO THE DEPTH SPECIFIED ABOVE. POST SHALL NOT BE DRIVEN. THE BACKFILL MATERIAL SHALL CONFORM TO THE REQUIREMENTS OF GRANULAR BACKFILL FOR STRUCTURES OR SHALL BE MATERIAL APPROVED BY THE ENGINEER. COMPACTION OF THE BACKFILL WILL BE DONE AS DIRECTED BY THE ENGINEER.

IN AREAS WHERE LEDGE ROCK IS ENCOUNTERED POSTS WILL BE SET AND GROUTED 24" DEEP IN THE LEDGE UNLESS THE POSTS PENETRATE THE GROUND 4".

FLAT STONE TO OBTAIN MORE BEARING AREA DURING THE INSTALLATION PHASE

REVISIONS AND CORRECTIONS

APPROVED

SEPT. 10, 1987
DATE

David B. Kelly
CHIEF ENGINEER
Alphon J. Goss
DIRECTOR OF PLANNING
AND PRE-CONSTRUCTION
S. B. MacArthur
TRAFFIC AND SAFETY ENGINEER

TUBULAR ALUMINUM SIGN POST



STANDARD
E-162