

\* WHEN CONSTRUCTING MULTIPLE POST INSTALLATIONS, THE POST SPACING SHALL BE A MINIMUM OF 7'-4" CENTER TO CENTER OF THE POSTS UNLESS USED BEHIND GUARDRAIL A DISTANCE  $\geq$  THE DEFLECTION DISTANCE (SEE STD. E-160).

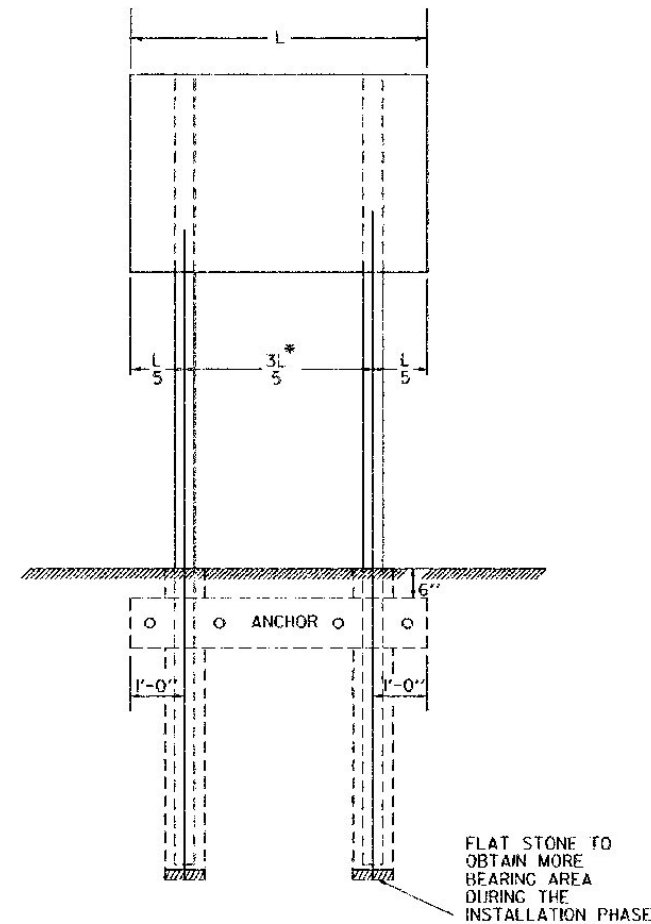

IN AREAS WHERE LEDGE ROCK IS ENCOUNTERED POSTS WILL BE SET AND GROUTED WITH TYPE 4 MORTAR, 24" BELOW THE TOP SURFACE OF THE SOLID ROCK UNLESS THE POSTS PENETRATE THE GROUND A MIN. 4'.

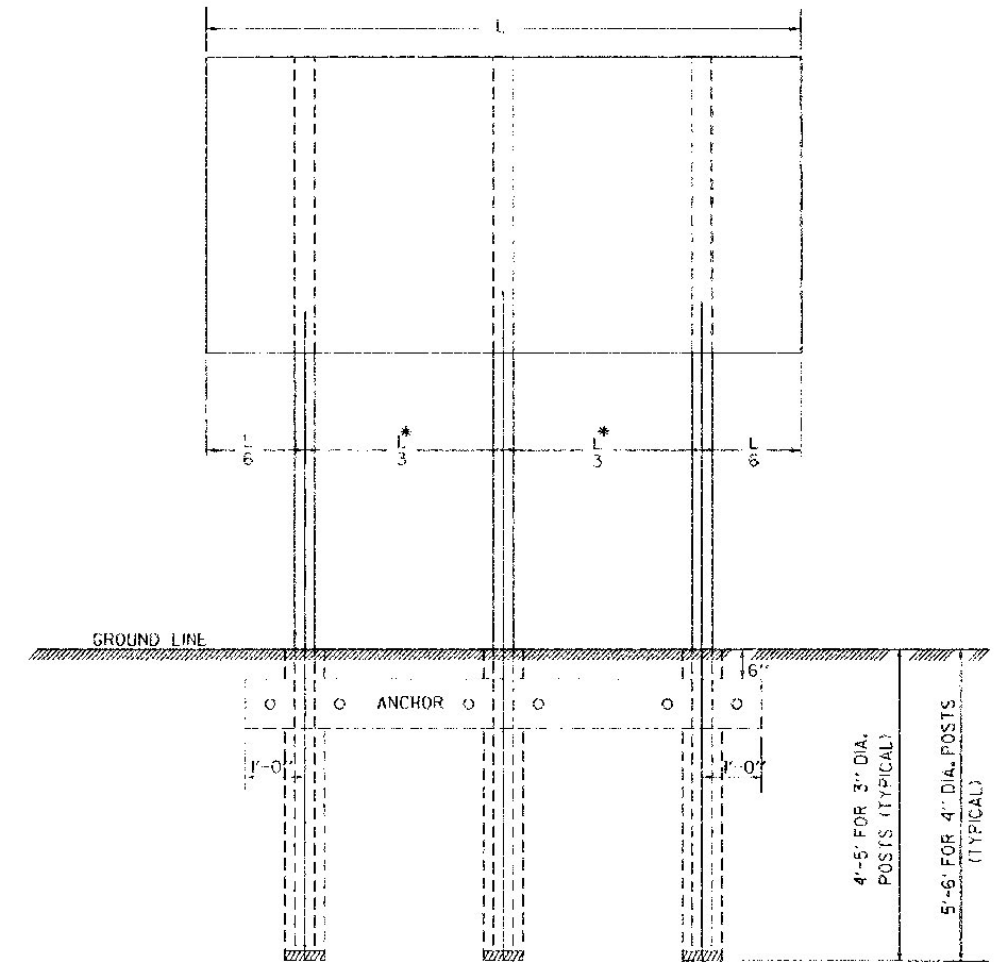

**NOTES**

**ANCHORS** USE TWO (2) PIECES OF 2" x 12" ROUGH PLANK, PLANKS, UNLESS OTHERWISE NOTED, SHALL CONFORM TO "STANDARD SPECIFICATIONS FOR CONSTRUCTION" SECTION 728.02

**ERECTION** LOCKNUTS ON 3/8" # 16 ALUMINUM POST BOLT CLIPS SHALL BE TORQUED TO 225 INCH POUNDS USING DRY, CLEAN, UNLUBRICATED THREADS. WHERE ALUMINUM SURFACES ARE TO BE PLACED IN CONTACT WITH WOOD, THEY SHALL BE GIVEN A THICK COAT OF AN ALKALI-RESISTANT BITUMINOUS PAINT MEETING THE REQUIREMENTS OF MILITARY SPECIFICATION MIL-P-6883, WHICH SHALL BE DRY BEFORE INSTALLATION.

THE HOLE SHALL BE CAREFULLY DUG AND THE POST SET TO THE DEPTH SPECIFIED ABOVE. POST SHALL NOT BE DRIVEN. THE BACKFILL MATERIAL SHALL CONFORM TO THE REQUIREMENTS OF APPROVED GRAVEL OR SHALL BE A MATERIAL APPROVED BY THE ENGINEER. COMPACTION OF THE BACKFILL WILL BE PERFORMED AS DIRECTED BY THE ENGINEER.

**OTHER STDS. E-160 REQUIRED:**



**STANDARD E-162**

POST SELECTION CHART		
SIGN AREA (FT. <sup>2</sup> ) x H (FT.) ≤ SV (SELECTION VALUE)		
POST SIZE	Sv (FT. <sup>2</sup> )	DESIGN CRITERIA
3" DIA.	182	WIND VELOCITY = 60 MPH (10 YEAR MEAN RECURRENCE INTERVAL)
4" DIA. *	334	WIND PRESSURE = 13 PSF
4" DIA. (MOD) *	329	ALUMINUM F <sub>y</sub> = 24,000 PSI ALLOWABLE STRESS = 1.4 (24,000) PSI

TWO POST INSTALLATIONS - USE ONLY BEHIND GUARDRAIL  
\* AT A DISTANCE  $\geq$  THE GUARDRAIL DEFLECTION DISTANCE.  
(SEE STD. E-160)

POST WEIGHTS		
POST DIAMETER	WALL THICKNESS	WEIGHT PER FT.
3" ROUND	1/8"	1.3 LBS
4" ROUND	1/8"	1.7 LBS
4" ROUND (MOD.)	1/8"	1.7 LBS

**REVISIONS AND CORRECTIONS**

SEPT. 10, 1987 - DATE OF ORIGINAL ISSUE  
MAR. 11, 1988 - FHWA REVIEW COMMENTS  
AUG. 18, 1995 - REVISED POST WALL THICKNESS AND APPROPRIATE VALUES. ADDED 4" DIAMETER (MOD.) POST.

APPROVED FOR THIS PROJECT AND/OR DESIGN IMPLEMENTATION. FHWA FINAL APPROVAL PENDING.

**APPROVED**

*Frank J. McCallister*  
DIRECTOR OF ENGINEERING

*David A. Ross*  
TRAFFIC AND SAFETY ENGINEER

**TUBULAR ALUMINUM SIGN POST**