

W2-2M

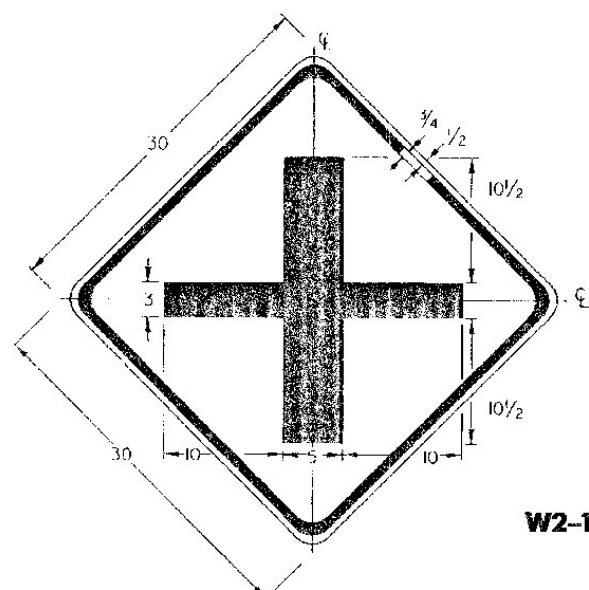

W2-1M

STATE ROUTE /TOWN HIGHWAY INTERSECTION SIGNS (TYP.)

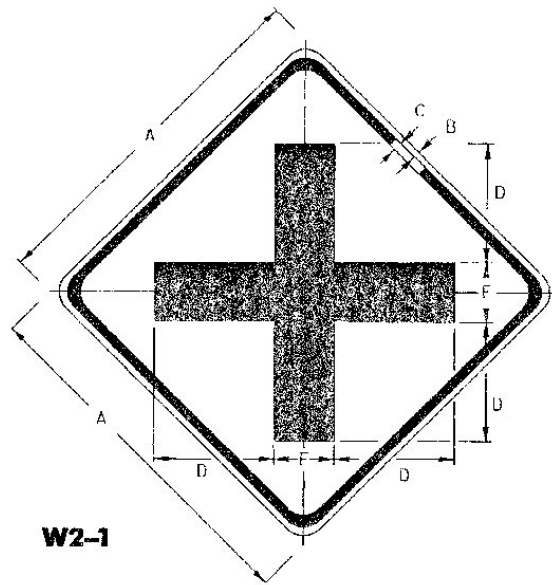

W2-1

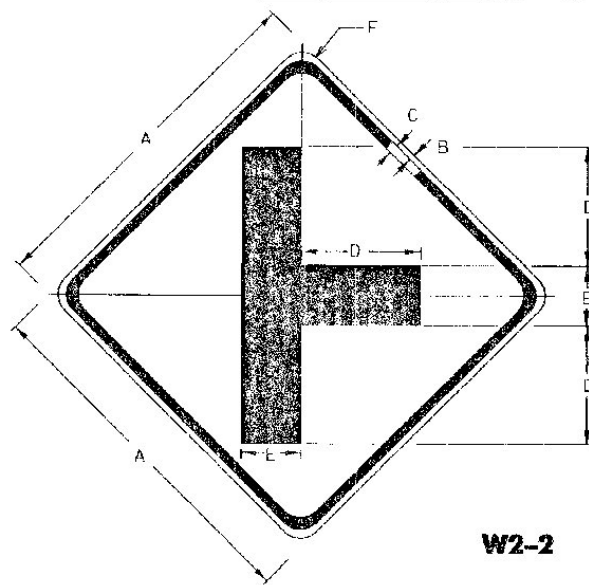

W2-2

SIGN	DIMENSIONS (INCHES)					
	A	B	C	D	E	F
BIKE	18	3/8	5/8	6	3	1 1/2
MIN.	24	3/8	5/8	8	4	1 1/2
STD.	30	1/2	3/4	10	5	1 1/8
EXPWY.	36	5/8	7/8	12	6	2 1/4
SPECIAL	48	3/4	1 1/4	16	8	3

SIGN	DIMENSIONS (INCHES)					
	A	B	C	D	E	F
BIKE	18	3/8	5/8	6	3	1 1/2
MIN.	24	3/8	5/8	8	4	1 1/2
STD.	30	1/2	3/4	10	5	1 1/8
EXPWY.	36	5/8	7/8	12	6	2 1/4
SPECIAL	48	3/4	1 1/4	16	8	3

STATE ROUTE /STATE ROUTE INTERSECTION SIGNS (TYP.)

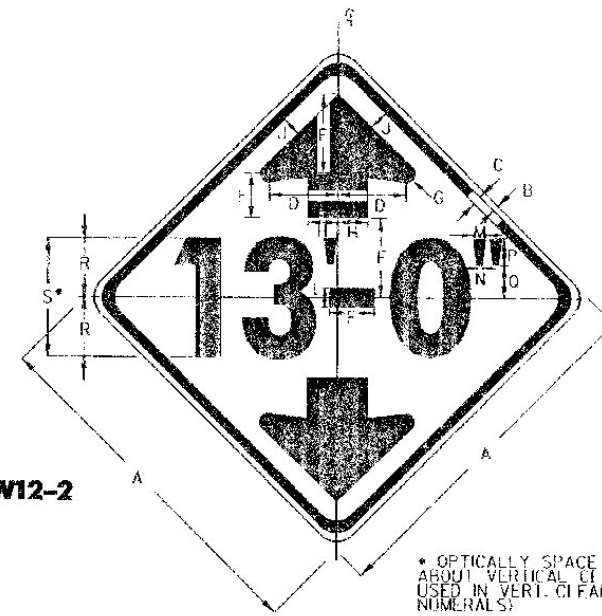

W12-2

\* OPTICALLY SPACE VERTICAL CLEARANCE ABOUT VERTICAL CENTERLINE (WHERE 10" IS USED IN VERT. CLEARANCE, USE SERIES 'C' NUMERALS)

SIGN	DIMENSIONS (INCHES)																
	A	B	C	D	E	F	G	H	J	K	L	M	N	P	Q	R	S
MIN.	30	1/2	3/4	5 3/4	6 3/8	3 3/4	3/4	2 1/2	1 1/8	1 1/8	1 1/8	1	1/16	2 1/4	3 3/8	5	10D
STD. & EXPWY.	36	5/8	7/8	6 3/8	8	4 1/2	1	3	2	2 1/4	1 7/8	1 1/4	1/2	2 3/4	4	6	12D
FWY.	48	3/4	1 1/4	9 3/8	10 3/8	5 3/8	1 3/8	4	2 5/8	3	2 1/16	1 3/8	3/8	3 5/8	5 1/2	8	16D

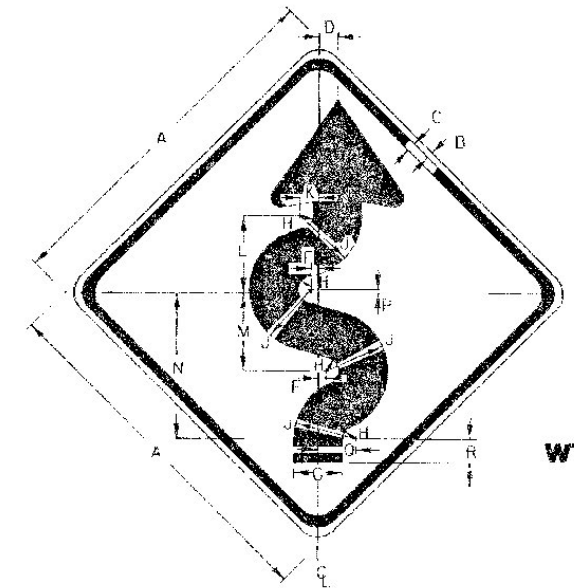

W1-5

SIGN	DIMENSIONS (INCHES)																
	A	B	C	D	E	F	G	H	J	K	L	M	N	P	Q	R	S
BIKE	18	3/8	5/8	6	3	1 1/2	3/8	2 1/2	1 1/8	1 1/8	1 1/8	1	1/16	2 1/4	3 3/8	5	10D
MIN.	24	3/8	5/8	8	4	1 1/2	3/8	2 1/2	1 1/8	1 1/8	1 1/8	1	1/16	2 1/4	3 3/8	5	10D
STD.	30	1/2	3/4	10	5	1 1/8	1/2	2 1/4	1 1/8	1 1/8	1 1/8	1	1/16	2 1/4	3 3/8	5	10D
EXPWY.	36	5/8	7/8	12	6	2 1/4	1/2	2 3/4	1 1/8	1 1/8	1 1/8	1	1/16	2 1/4	3 3/8	5	10D
SPECIAL	48	3/4	1 1/4	16	8	3	1/2	3 1/4	1 1/8	1 1/8	1 1/8	1	1/16	2 1/4	3 3/8	5	10D

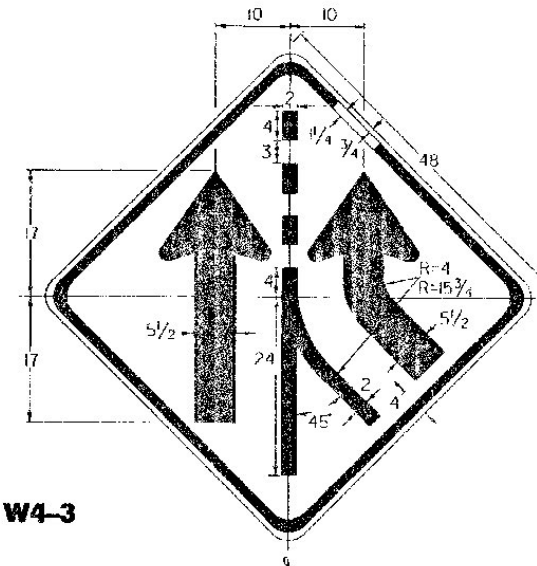

W4-3

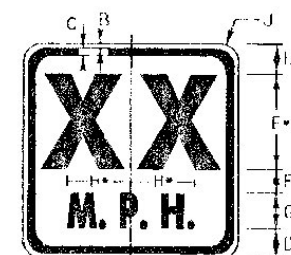

W13-1

SIGN	DIMENSIONS (INCHES)									
	A	B	C	D	E	F	G	H	J	
STD.	18	3/8	5/8	2 1/2	8E	2	3E	5 1/8	1 1/2	
SPECIAL	24	3/8	5/8	3 3/8	10E	2 1/4	4E	7 1/8	1 1/2	

\* INCREASE SPACING 100%  
 \*\* OPTICALLY SPACE NUMERALS ABOUT VERTICAL CENTERLINE

COLORS:

ALL THE WARNING SIGNS SHOWN ON THIS SHEET SHALL HAVE BLACK TEXT AND SYMBOLS ON REFLECTORIZED YELLOW BACKGROUND EXCEPT AS OTHERWISE NOTED. THE COLORS SHALL CONFORM WITH THE COLORS ADOPTED BY THE AMERICAN ASSOCIATION OF STATE HIGHWAY AND TRANSPORTATION OFFICIALS AND APPROVED BY THE DEPARTMENT OF TRANSPORTATION AND THE FEDERAL HIGHWAY ADMINISTRATION.

MATERIALS:

THE SIGN BASE MATERIALS USED FOR THE WARNING SIGNS SHOWN ON THIS SHEET MAY BE ANY OF THE FOLLOWING, OF MINIMUM THICKNESS NOTED.

	FLAT SHEET ALUMINUM	HIGH DENSITY OVERLAID PLYWOOD	GALVANIZED FLAT SHEET STEEL
	18" X 18"	0.060"	1/2"
24" X 24", 30" X 30"	0.080"	1/2"	16 GAGE
36" X 36"	0.100"	5/8"	14 GAGE
48" X 48"	0.125"	3/4"	12 GAGE

THE TEXT, BORDER AND SYMBOLS SHALL BE LETTERING FILM, SILK SCREENED OR HAND PAINTED. WHEN HAND PAINTED, POOR WORKMANSHIP SHALL BE CAUSE FOR REJECTION. THE REFLECTIVE MATERIAL SHALL BE REFLECTIVE SHEETING APPLIED TO THE ENTIRE BACKGROUND OF THE SIGN. ENCAPSULATED LENS REFLECTIVE SHEETING SHALL BE USED FOR THE SIGN BACKGROUND WHERE NOTED.

TEXT:

LETTERS, DIGITS, SYMBOLS, SPACINGS, AND TEXT DIMENSIONS SHALL CONFORM WITH THE STANDARD ALPHABETS AND DESIGNS PRESCRIBED IN THE MANUAL ON UNIFORM TRAFFIC CONTROL DEVICES, SEE STANDARD SHEET E-150 FOR ARROWHEAD DETAILS.

SPECIFICATIONS:

WARNING SIGNS SHALL MEET THE VERMONT STANDARD SPECIFICATIONS FOR "TRAFFIC SIGNS".

OTHER STDS. E-150 REQUIRED:

REVISIONS AND CORRECTIONS  
 AUG. 08, 1995 - DATE OF ORIGINAL ISSUFI

APPROVED

*Stanley D. MacArthur*  
 DIRECTOR OF ENGINEERING

*David A. Ross*  
 TRAFFIC AND SAFETY ENGINEER

APPROVED FOR THIS PROJECT  
 AND/OR DESIGN IMPLEMENTATION.  
 HWA FINAL APPROVAL PENDING.

WARNING SIGN  
 DETAILS



STANDARD  
 E-155