

MOUNTING HEIGHTS WITHOUT GUARD RAIL

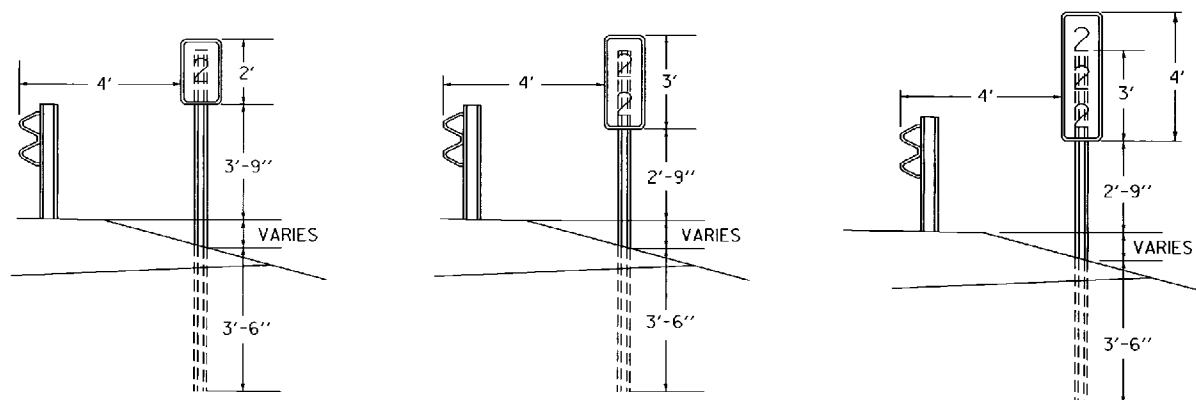

MOUNTING HEIGHTS WITH GUARD RAIL

"MILE MARKERS SHALL BE ELIMINATED IF THEY OCCUR ON A BRIDGE. A MILEPOST TYPE A PLAQUE WITH A TYPE B PLAQUE READING "00" WILL BE SUBSTITUTED FOR THE MILEMARKER. MILEPOST PLAQUE DETAILS ARE SHOWN ON THE APPROPRIATE STANDARD SHEETS.

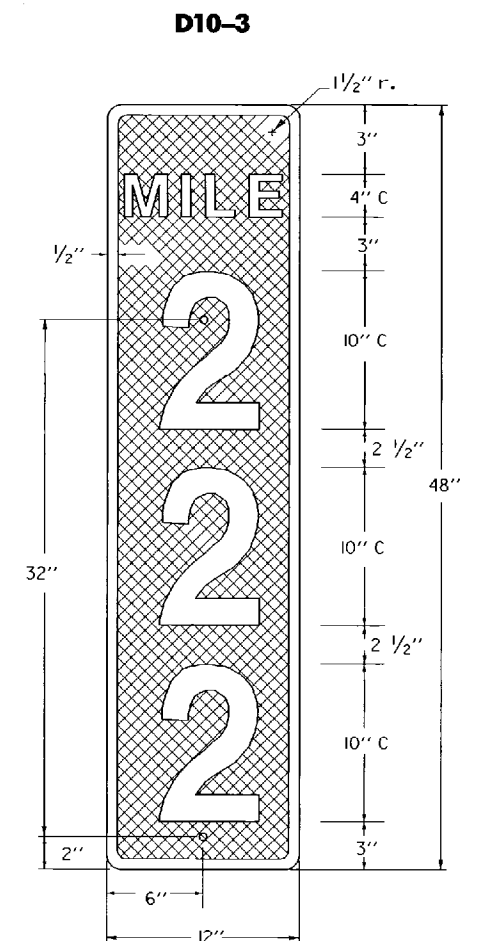
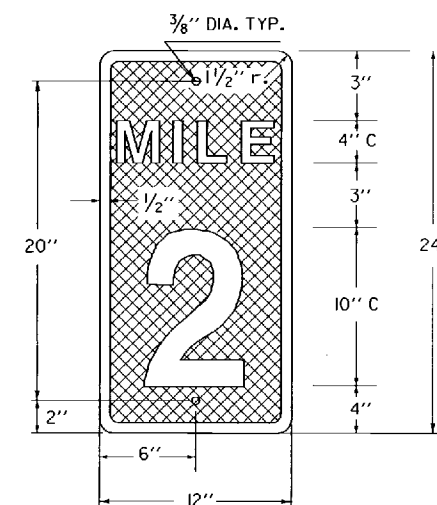
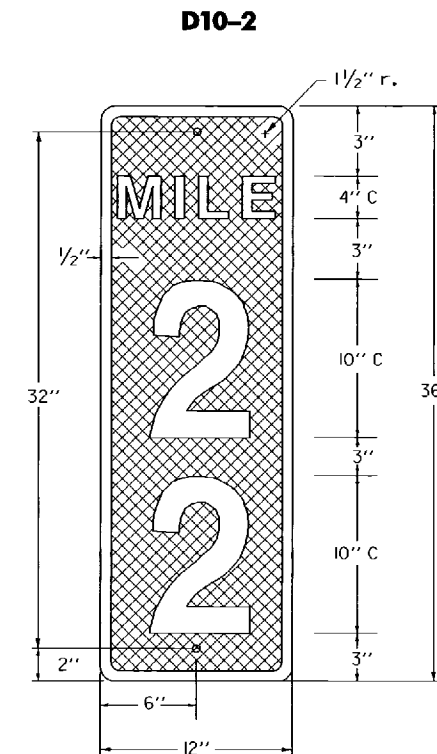

COLORS:

THE SIGNS SHALL HAVE WHITE REFLECTIVE NUMERALS, BORDER AND LEGEND ON A GREEN REFLECTORIZED BACKGROUND. THE GREEN REFLECTIVE MATERIAL SHALL BE REFLECTIVE SHEETING APPLIED TO THE ENTIRE BACKGROUND OF THE SIGN. THE COLORS SHALL CONFORM WITH THE STANDARD COLOR TOLERANCE CHARTS APPROVED BY THE U. S. DEPARTMENT OF TRANSPORTATION AND FEDERAL HIGHWAY ADMINISTRATION.

TEXT:

LETTERS AND NUMBERS SHALL CONFORM WITH THE STANDARD ALPHABETS AND DESIGN AS PRESCRIBED IN THE PUBLICATION "STANDARD ALPHABETS FOR HIGHWAY SIGNS AND PAVEMENT MARKING". AVAILABLE FROM THE FEDERAL HIGHWAY ADMINISTRATION.

MATERIALS:

MILE MARKER SIGNS SHALL BE .080 FLAT SHEET ALUMINUM. SIGNS SHALL BE MOUNTED ON FLANGED CHANNEL STEEL SIGN SUPPORTS WEIGHING 3 LB PER LINEAR FOOT.

PAYMENT:

THE MILE MARKER SIGNS SHALL BE PAID AS TRAFFIC SIGNS TYPE A. THE POSTS SHALL BE PAID AS FLANGED CHANNEL SIGN POSTS.

REVISIONS AND CORRECTIONS

SEPT. 10, 1987 - DATE OF ORIGINAL ISSUE
 AUG. 08, 1995 - MINOR NOTE REVISIONS
 APRIL 01, 1998 - CHANGED NUMBERS ON SIGN DETAILS D1E TO A DISCRIMINATION COMPLAINT

APPROVED

[Signature]
 DIRECTOR OF PROJECT DEVELOPMENT

[Signature]
 DIRECTOR OF CONSTRUCTION AND MAINTENANCE

**MILEMARKER DETAILS
 INTERSTATE**

**OTHER STDS. E-160
 REQUIRED:**



**STANDARD
 E-139**