

1 OR 2 DIGIT STATE ROUTE MARKER

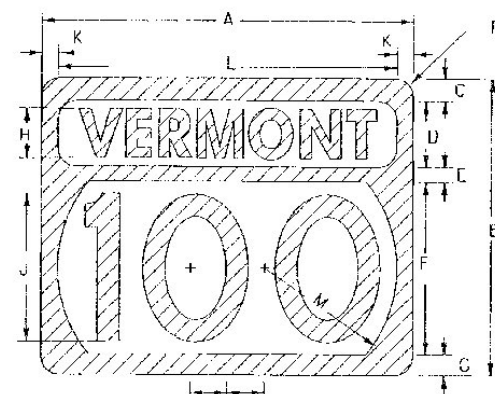

3 DIGIT STATE ROUTE MARKER



1 OR 2 DIGIT ALTERNATE STATE ROUTE MARKER

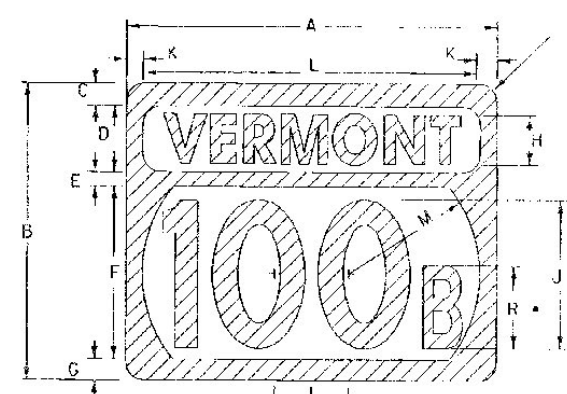

3 DIGIT ALTERNATE STATE ROUTE MARKER

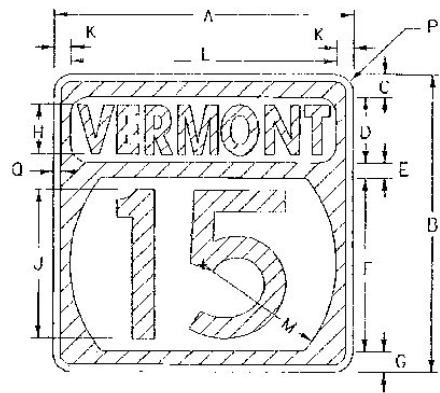

STATE ROUTE MARKER FOR GUIDE SIGN USE (INTERSTATE TYPICAL)

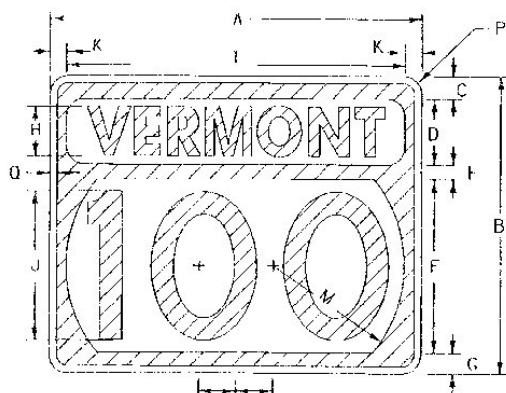

ALTERNATE ROUTE SIGNS: OPTICALLY SPACE NUMERALS ABOUT VERTICAL CENTERLINE AND REDUCE SPACING AS NECESSARY FOR EACH ROUTE

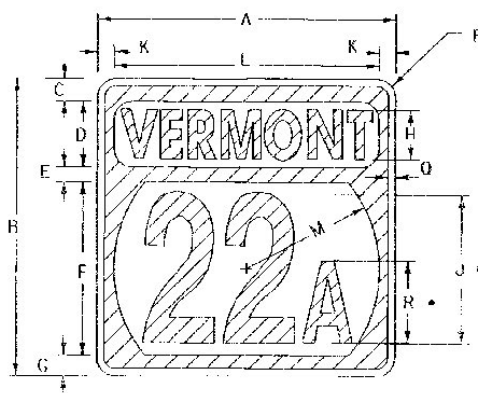

ALTERNATE STATE ROUTE MARKER FOR GUIDE SIGN USE (INTERSTATE TYPICAL)

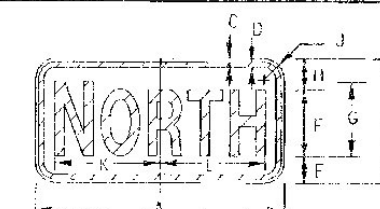
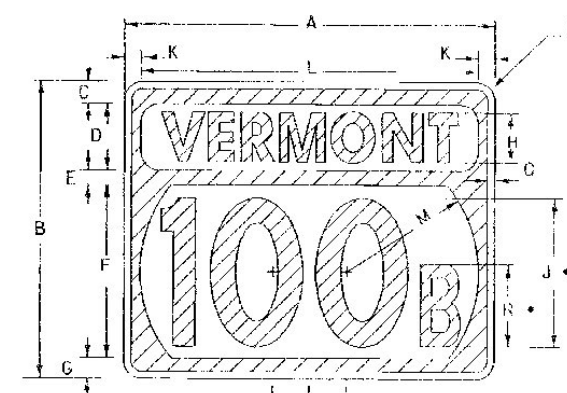

M3-1 M3-3 M3-2 M3-4

SIGN	DIMENSIONS (INCHES)																
	NORTH				SOUTH				EAST				WEST				
MIN. & STD.	A	B	C	D	E	F	G	H	J	K	L	K	L	K	L	K	L
SPECIAL	24	17	3/8	5/8	2 1/4	6C	7C	3 1/4	1 1/2	10 1/4	10 1/4	10 1/4	9 3/8	7 3/8	8 3/8	8 3/4	8 3/8
SPECIAL	30	15	3/8	5/8	3 1/4	8C	9C	3 3/4	1 1/2	12 1/8	12 1/8	12 1/8	10 1/2	10 3/8	11 1/8	11 3/8	11 3/8

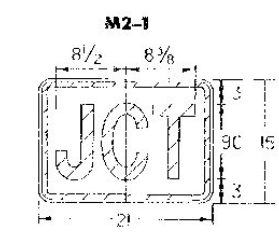

M2-1 CARDINAL DIRECTION MARKER

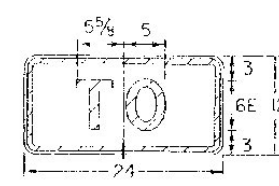
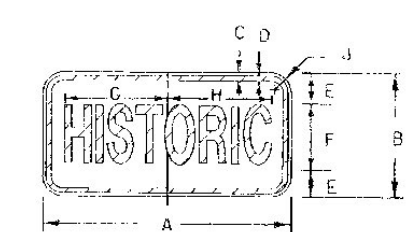

M4-5 TRAILBLAZER

SIGN	DIMENSIONS (INCHES)									
	A	B	C	D	E	F	G	H	J	
MIN. & STD.	24	12	3/8	5/8	3 1/2	5B	10 1/8	9 3/8	1 1/2	
SPECIAL	30	15	3/8	5/8	4	7B*	12 3/8	12 3/8	1 1/2	

* REDUCE SPACING 35%

MATERIALS

THE SIGN BASE MATERIAL MAY BE ANY OF THE FOLLOWING, WITH THE MINIMUM THICKNESSES AS NOTED:
 FLAT SHEET ALUMINUM
 LESS THAN 24" X 24" 0.060"
 WHEN USED ON GUIDE SIGNS 0.060"
 24" X 24" 30" X 24" 0.080"
 36" X 36" 45" X 36" 0.100"
 GALVANIZED FLAT SHEET STEEL
 LESS THAN 24" X 24" 18 GAGE
 WHEN USED ON GUIDE SIGNS 18 GAGE
 24" X 24" 30" X 24" 17 GAGE
 30" X 36" 45" X 36" 14 GAGE

THE REFLECTIVE MATERIAL SHALL BE WHITE REFLECTIVE SHEETING APPLIED TO THE ENTIRE BACKGROUND. THE TEXTS MAY BE LETTERING FILM, SILK SCREENED, OR HAND PAINTED.

COLORS

COLORS FOR GUIDE USE: TEXT AND SHIELD - GREEN (REFL.) BACKGROUND AND BORDER - WHITE (REFL.)
 STATE ROUTE MARKERS SHALL HAVE REFLECTIVE GREEN TEXT AND BORDERS ON REFLECTORIZED WHITE BACKGROUNDS.
 GREEN AREAS ARE INDICATED BY SINGLE LINE CROSSHATCHING

LETTERING

LETTERS AND DIGITS SHALL CONFORM WITH THE "STANDARD ALPHABET FOR HIGHWAY SIGNS AND PAYMENT MARKINGS" ADOPTED BY THE U.S. DEPARTMENT OF TRANSPORTATION AND FHWA.

SPECIFICATIONS

STATE ROUTE MARKERS AND AUXILIARY ROUTE MARKERS SHALL MEET THE STANDARD STATE SPECIFICATIONS FOR TRAFFIC SIGNS.

DESIGNS

THE DESIGNS OF STATE ROUTE MARKERS AND AUXILIARY MARKERS SHALL CONFORM WITH THE REQUIREMENTS SET FORTH IN THE "MANUAL ON UNIFORM TRAFFIC CONTROL DEVICES" ADOPTED BY THE U.S. DEPARTMENT OF TRANSPORTATION AND FHWA.

SIGN	DIMENSIONS (INCHES)															
	A	B	C	D	E	F	G	H	J	K	L	M	N	P	Q	R
1,2-digits	24	24	1 1/2	6	1	14	1 1/2	4C	12D	1	22	11	-	1 1/2	1/2	7B
1,2-digits	36	36	2 3/8	8	1 3/4	21	2 3/8	6C	18D	2	32	16 1/2	-	2 1/4	3/8	10B
3-digits	30	24	1 1/2	6	1	14	1 1/2	4D	12D	1	28	11	3	1 1/2	1/2	7B
3-digits	45	36	2 3/8	8	1 3/4	21	2 3/8	6D	18D	2	41	16 1/2	4 1/2	2 1/4	3/8	10B

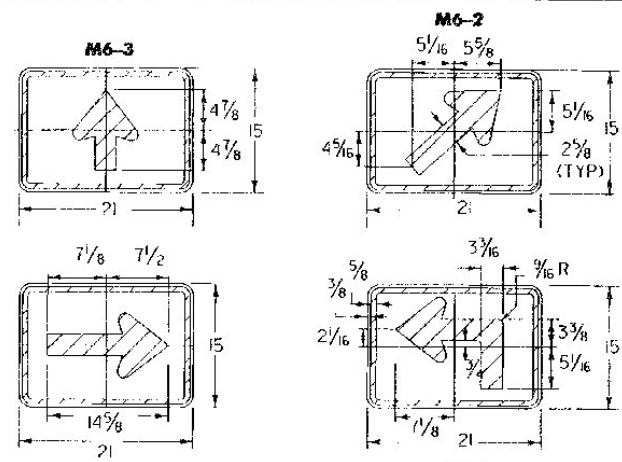

M6-1 M6-2 M6-3 DIRECTION ARROW OR ADVANCE TURN ARROWS

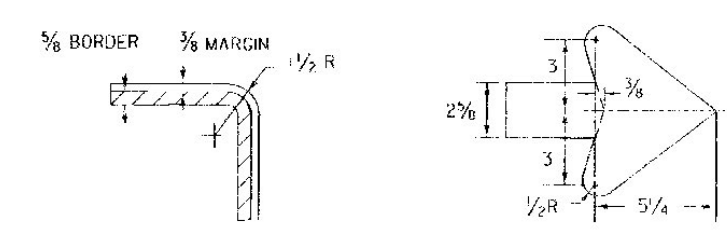

TYPICAL RADIUS DETAIL TYPICAL ARROW DETAIL

(ALL DIMENSIONS IN INCHES)

REVISIONS AND CORRECTIONS
 AUG. 08, 1995 - DATE OF ORIGINAL ISSUE

APPROVED
Stephen H. MacArthur
 DIRECTOR OF ENGINEERING

David A. Ross
 TRAFFIC AND SAFETY ENGINEER

STATE ROUTE MARKER
 SIGN DETAILS

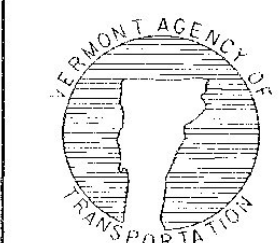

STANDARD
 E-136 B

APPROVED FOR THIS PROJECT AND/OR DESIGN IMPLEMENTATION. FHWA FINAL APPROVAL PENDING.