

TYPICAL SIGN TEXTS

INTERSTATE SHIELD FOR INDEPENDENT AND GUIDE SIGN USE

SIGN	DIMENSIONS (INCHES)												
	A	B	C	D	E	F	G	H	J	K	L	M	
1,2-DIGITS	24	24	1/2	6 1/2	12	0	5 1/2	5	15	15	2	2 1/2	7 1/8
1,2-DIGITS	36	36	3/4	9 3/4	18	0	8 1/4	7 1/2	22 1/2	22 1/2	3	3 3/4	11 1/8
1,2-DIGITS	48	48	1	13	24	0	11	10	30	30	4	5	15 1/8
3-DIGITS	30	24	1/2	6 1/2	12	0	5 1/2	5	24	17	2	2 1/2	7 1/8
3-DIGITS	45	36	3/4	9 3/4	18	0	8 1/4	7 1/2	36	25 1/2	3	3 3/4	11 1/8
3-DIGITS	60	48	1	13	24	0	11	10	48	34	4	5	15 1/8

COLORS

LEGEND
TOP - WHITE (REFL)
BOTTOM - RED (REFL)
-BLUE (REFL)

* OPTICALLY SPACE NUMERALS ABOUT VERTICAL CENTERLINE

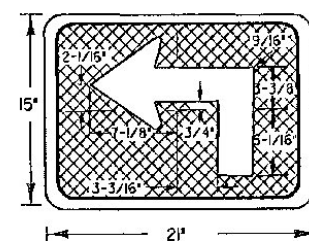
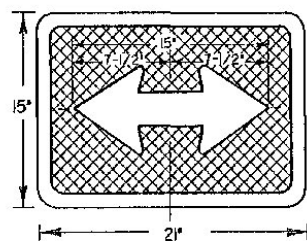

* OTHER DIMENSIONS SEE ADVANCE TURN ARROW.

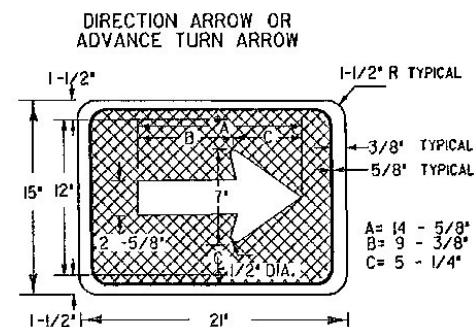
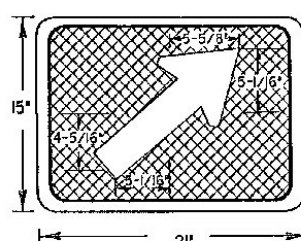
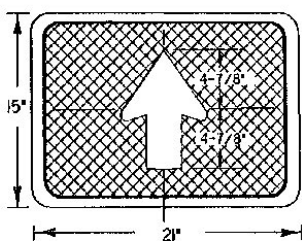

COLORS

THE OFFICIAL INTERSTATE ROUTE MARKER SHALL HAVE A REFLECTORIZED WHITE OR SILVER TEXT AND BORDER ON A REFLECTORIZED RED AND BLUE BACKGROUND. AUXILIARY MARKERS USED WITH INTERSTATE ROUTE MARKERS SHALL HAVE A REFLECTORIZED WHITE AND SILVER TEXT AND BORDER ON A REFLECTORIZED BLUE BACKGROUND.

THE RED AND BLUE SHALL CONFORM WITH THE STANDARD COLORS ADOPTED BY THE AMERICAN ASSOCIATION OF STATE HIGHWAY AND TRANSPORTATION OFFICIALS AND APPROVED BY THE U.S. DEPARTMENT OF TRANSPORTATION, FEDERAL HIGHWAY ADMINISTRATION.

LETTERING

LETTERS AND DIGITS SHALL CONFORM WITH THE "STANDARD ALPHABETS FOR HIGHWAY SIGNS" APPROVED BY THE NATIONAL JOINT COMMITTEE ON UNIFORM TRAFFIC CONTROL DEVICES.

SPECIFICATIONS

INTERSTATE ROUTE MARKERS AND AUXILIARY ROUTE MARKERS SHALL MEET THE STANDARD STATE SPECIFICATIONS FOR "TRAFFIC SIGNS."

DESIGNS

THE DESIGNS OF INTERSTATE ROUTE MARKERS AND AUXILIARY MARKERS SHALL CONFORM WITH THE REQUIREMENTS SET FORTH IN THE MANUAL ON UNIFORM TRAFFIC CONTROL DEVICES ADOPTED BY THE AMERICAN ASSOCIATION OF STATE HIGHWAY AND TRANSPORTATION OFFICIALS.

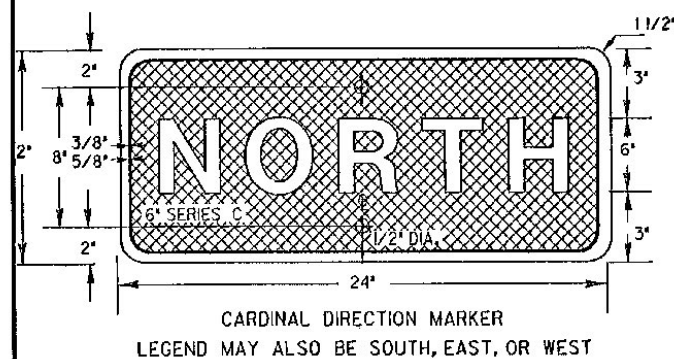

CARDINAL DIRECTION MARKER
LEGEND MAY ALSO BE SOUTH, EAST, OR WEST

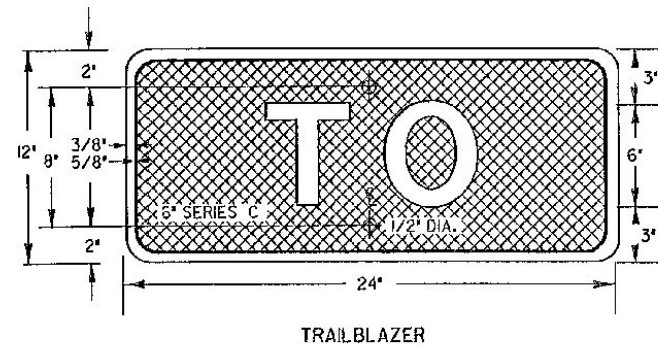

TRAILBLAZER

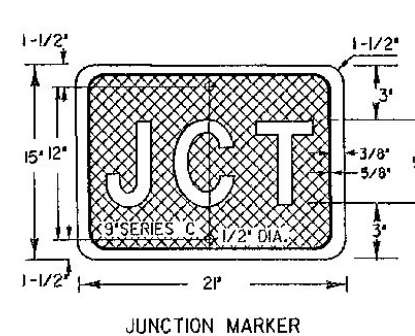

JUNCTION MARKER

REVISIONS AND CORRECTIONS

APPROVED

SEPT. 10, 1987
DATE
David B. Kelly
CHIEF ENGINEER
Arthur J. ...
DIRECTOR OF PLANNING
AND PRE-CONSTRUCTION
... ..
TRAFFIC AND SAFETY ENGINEER

INTERSTATE ROUTE MARKER
SIGN DETAILS



STANDARD
E-135