

EDGE MOLDING ASTM B221 ALLOY T6 B.E. FINISH COLOR TO MATCH SIGN FACE

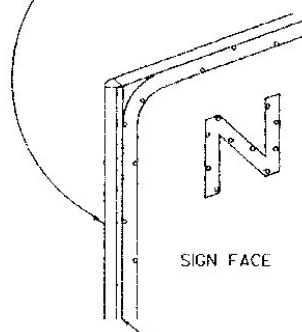

BORDER EVEN WITH SIGN EDGE AT TOP AND BOTTOM AND BUTTS EDGE MOLDING ON SIDES.

INDIVIDUAL LETTERS, DIGITS, SYMBOLS, AND BORDERS FOR THE SIGN SHALL BE SHAPED FROM 0.032 INCH SHEET ALUMINUM CONFORMING TO THE REQUIREMENTS OF ASTM B 209, ALLOY 3003-H12. LEGEND AND BORDER TO BE ATTACHED TO THE SIGN FACE WITH 1/8" RIVETS.



SERVICE SIGN MOUNTING DETAILS

WHEN USED, THE SERVICE SIGNS SHALL APPEAR IN THE SAME SEQUENCE AS SHOWN ABOVE. THE PARENT SIGN SHOWN IS ONLY AN EXAMPLE. THE SIGNS SHALL BE INSTALLED ON THE SIGN SHOWN ON THE PLANS. THE SERVICE SIGNS SHALL BE MOUNTED TO THE PARENT SIGN WITH TEE BARS AND EXTRUDED ALUMINUM RIBS. OTHER METHODS OF INSTALLATION MAY BE SUBMITTED TO THE TRAFFIC DESIGN SECTION FOR APPROVAL. IN NO CASE SHALL ANY SUPPORT BE ATTACHED TO THE W-SHAPED STEEL SIGN SUPPORT BELOW THE FUSE PLATE.

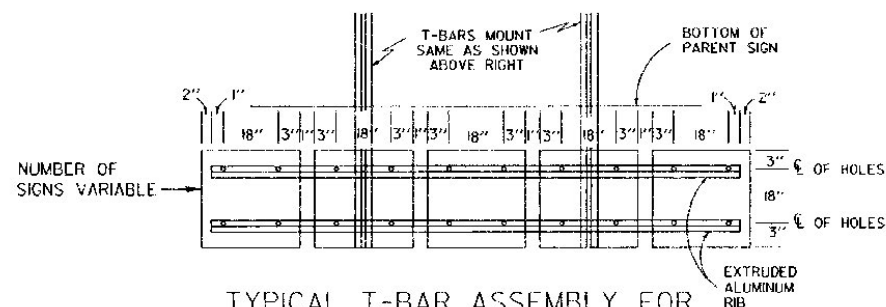

TYPICAL T-BAR ASSEMBLY FOR MOUNTING SERVICES SYMBOLS (24" x 24" UNITS SHOWN)

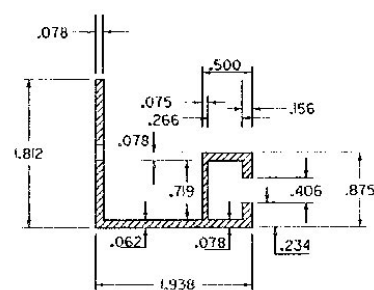

DETAIL EXTRUDED ALUMINUM RIB ALUM. ALLOY 6063-T6

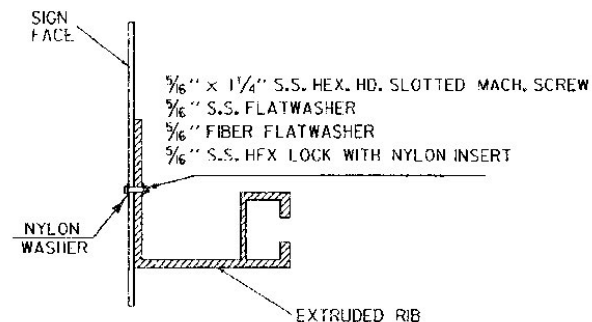

EXTRUDED ALUMINUM PANEL SIGN CLIP

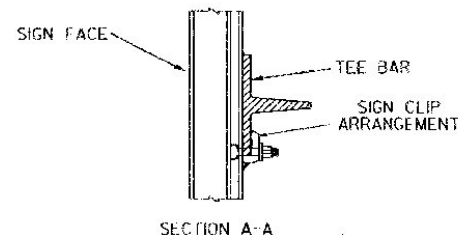
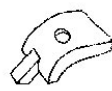

12" x 6" EXTRUDED ALUMINUM SIGN PANELS 6063-T6. 6" x 6" PANEL PLACED ON TOP WHEN REQUIRED. PANELS BOLTED TOGETHER ON 24" CENTERS WITH 3/8" x 1" STAINLESS STEEL HEX HEAD BOLT.

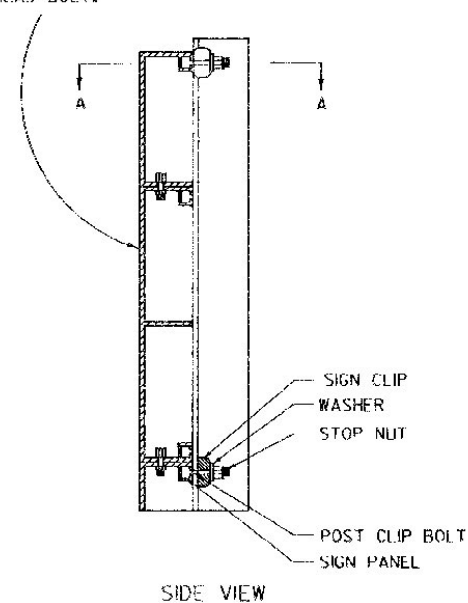

SIGN MOUNTING DETAIL

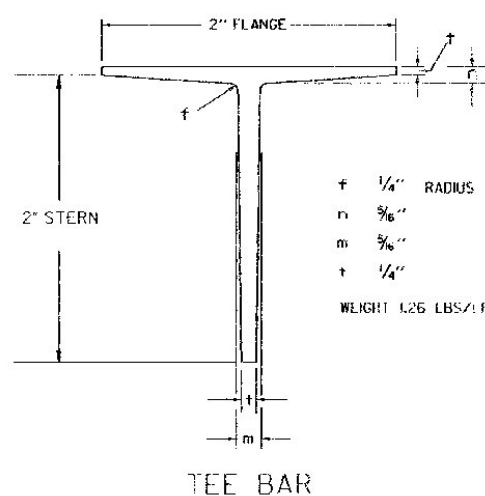

TEE BAR

NOTES

1. THE ALUMINUM TEE BAR SHALL BE OF 6063-T6 ALLOY.
2. EXTRUDED ALUMINUM PANEL SIGN CLIP SHALL BE 356-T6 ALLOY FABRICATED TO GIVE PROPER CLAMPING ON ALL FLANGES (TAPERED OR PARALLEL) FROM 1/8" TO 1 1/2" IN THICKNESS. A FLAT WASHER SHALL BE USED UNDER THE NUT.
3. BOLTS, NUTS AND WASHERS SHALL BE STAINLESS STEEL. BOLTS SHALL BE 3/8" DIAMETER, 2 INCHES IN LENGTH WITH A HEAD CAPABLE OF BEING INSERTED INTO EXTRUDED ALUMINUM SIGN PANEL SLOTS. NUTS SHALL BE OF A LOCK NUT DESIGN, THREADS MATCHING BOLT. THE WASHER SHALL HAVE A 3/4" I.D. x 3/4" O.D. x .09" THICKNESS.

X - DENOTES SIGN CLIP LOCATION (ONE POST AND T-BAR TYPICAL SHOWN)

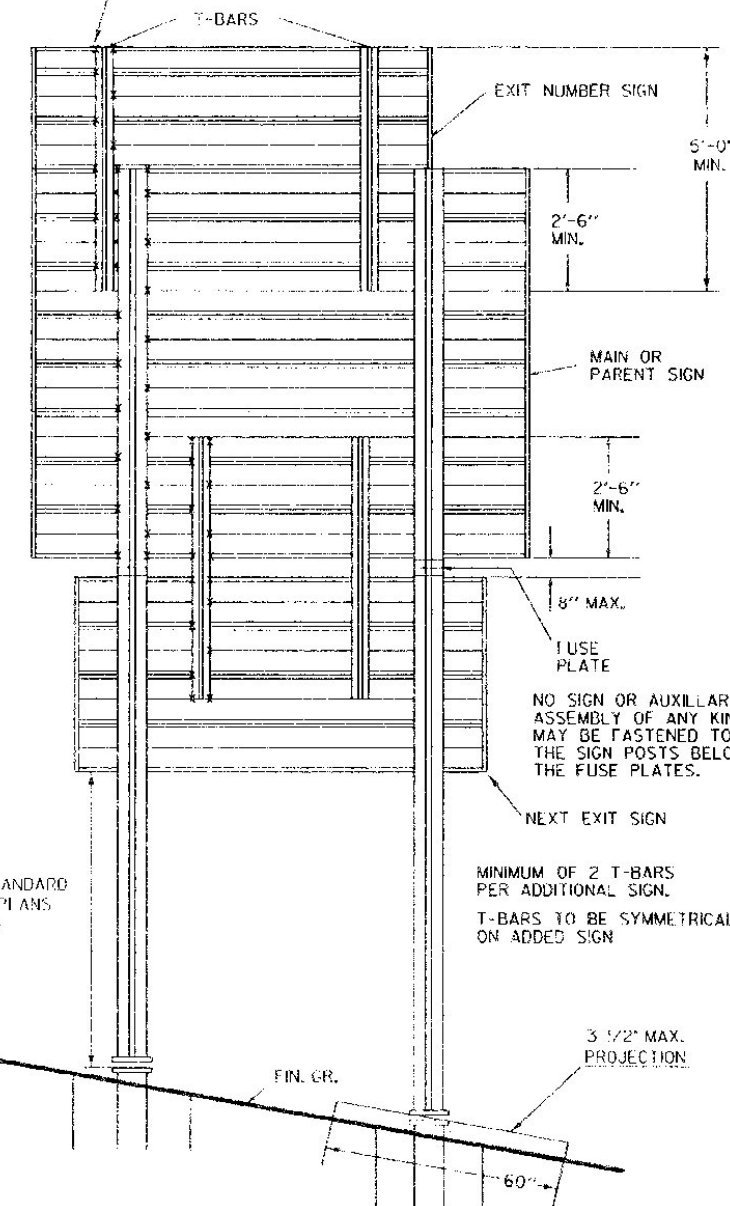

TYPICAL SIGN INSTALLATION ON W-SHAPED STEEL POSTS WITH T-BAR EXTENSIONS

OTHER STDS. REQUIRED:

REVISIONS AND CORRECTIONS

SEPT. 10, 1987 - DATE OF ORIGINAL ISSUE
MARCH 01, 1988 - MAJOR REVISIONS
AUG. 08, 1995 - MINOR REVISIONS

APPROVED

Stephen D. MacCulloch
DIRECTOR OF ENGINEERING

David A. Ross
TRAFFIC AND SAFETY ENGINEER

TYPE "B" GUIDE SIGN ATTACHMENT DETAILS



STANDARD E-130

APPROVED FOR THIS PROJECT AND/OR DESIGN IMPLEMENTATION. FHWA FINAL APPROVAL PENDING.