

U.S. ROUTE MARKER
FOR USE ON INTERSTATE GUIDE SIGNS

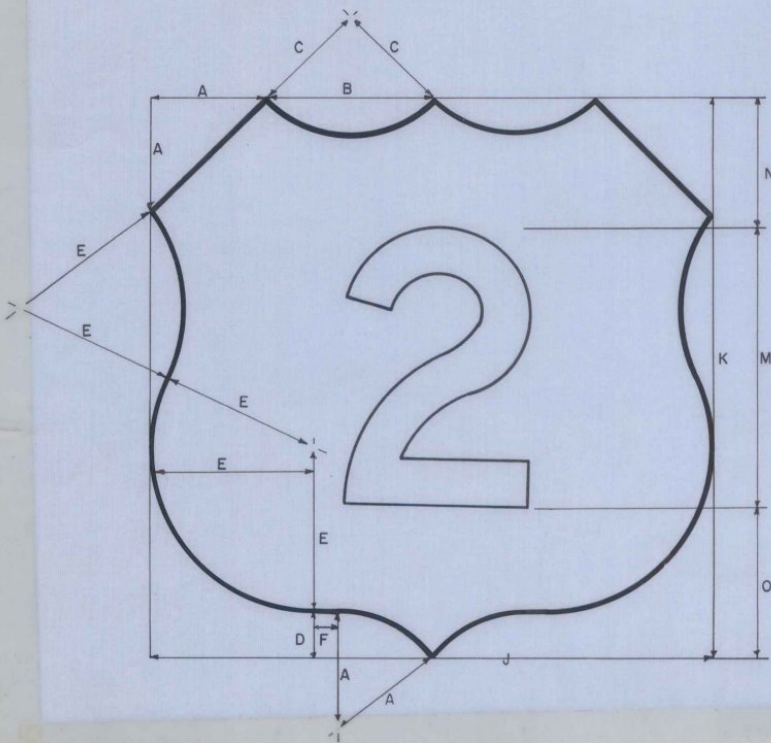

U. S. ROUTE MARKER
FOR INDEPENDENT USE WITH MARKER ASSEMBLIES

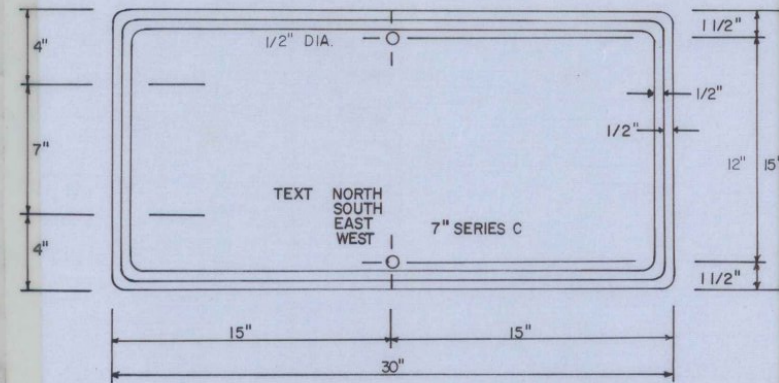
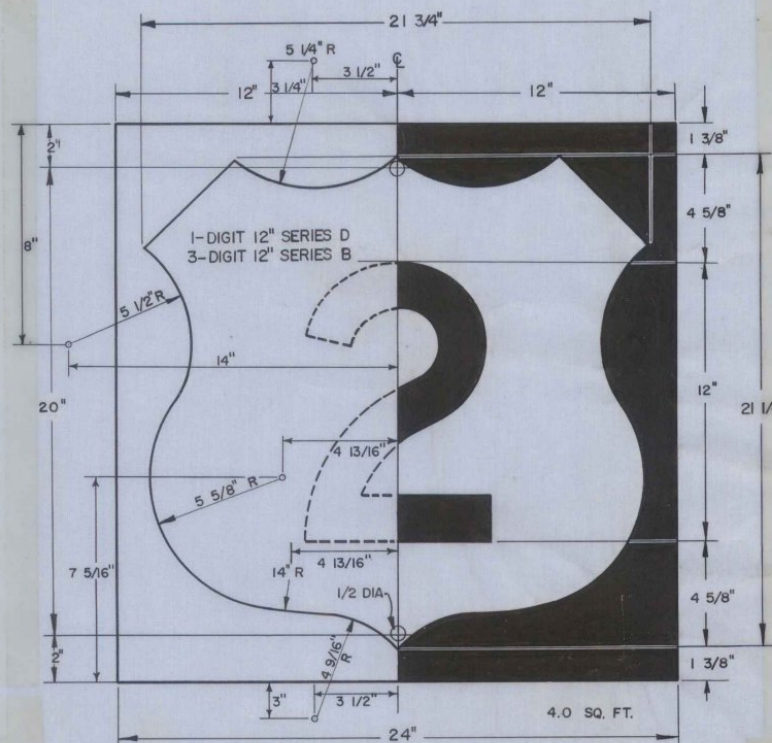

MATERIALS

The sign base material may be any of the following, of the minimum thickness noted:

- FLAT SHEET ALUMINUM
 - Less than 24" x 24" - 0.060"
 - 24" x 24" - 0.080"
- HIGH DENSITY OVERLAID PLYWOOD
 - Less than 24" x 24" - 3/8"
 - 24" x 24" - 1/2"
- GALVANIZED FLAT SHEET STEEL
 - Less than 24" x 24" - 18 gage
 - 24" x 24" - 16 gage

Route markers to be mounted on large guide signs, shall be of a thickness as for signs less than 24" x 24"

The reflective material shall be white or silver reflective sheeting, applied to the entire background. The texts may be lettering film, silk screened, or hand painted.

COLORS

State route markers and auxiliary markers shall have black texts on reflectorized white or silver backgrounds.

LETTERING

Letters and digits shall conform with the standard alphabets for highway signs approved by the National Joint Committee on Uniform Traffic Control Devices.

SPECIFICATIONS

State route markers and auxiliary route markers shall meet the standard state specifications for "Traffic Signs",

SHIELD SIZE	A	B	C	D	E	F	J	K	M	N	O
24" x 24"	5	7	5	2	7	1	24	24	12	5 1/2	6 1/2
30" x 24"	5	10	9	2	7	4	30	24	12	5 1/2	6 1/2
36" x 36"	7 1/2	10 1/2	7 1/2	3	10 1/2	1 1/2	36	36	18	8 1/4	9 3/4
45" x 36"	7 1/2	15	13 1/2	3	10 1/2	6	45	36	18	8 1/4	9 3/4
48" x 48"	10	14	10	4	14	2	48	48	24	11	13

DESIGNS.

The designs of U.S. Route Markers and auxiliary markers conform with the requirements set forth in the Manual on Uniform Traffic Control Devices prepared by the National Joint Committee on Uniform Traffic Control Devices.

CARDINAL DIRECTION MARKER

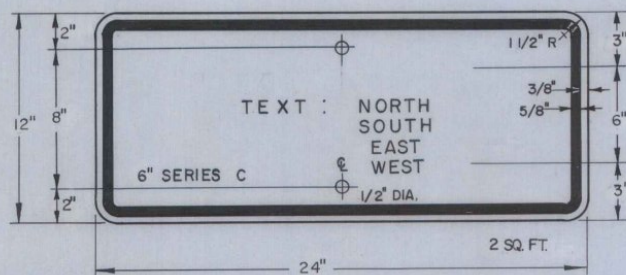

TRAILBLAZER

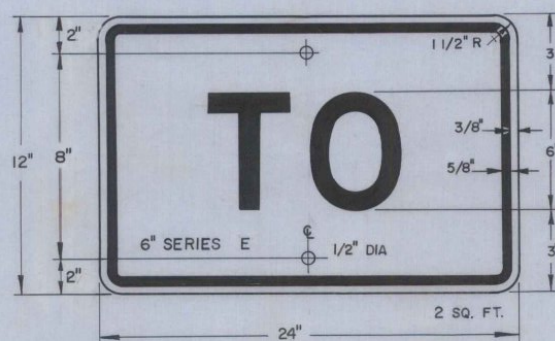

JUNCTION MARKER

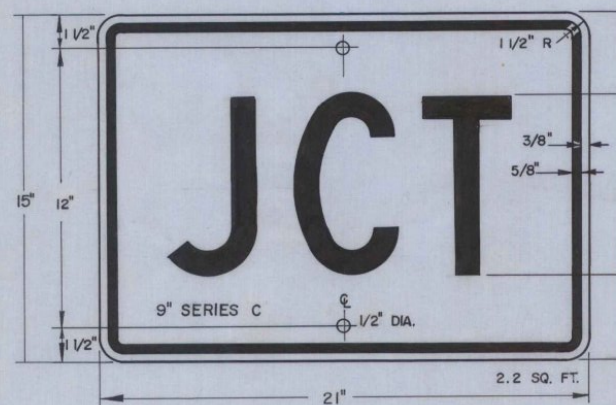

DIRECTION ARROW OR
ADVANCE TURN ARROW
(SEE STANDARD E-11 FOR ARROW DESIGN DETAILS)

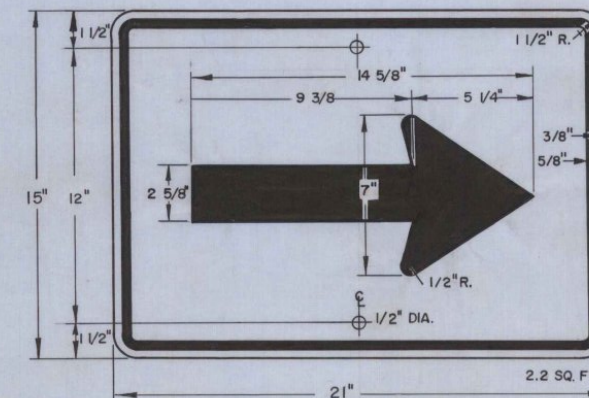

NOTE:
FOR ADDITIONAL ADVANCE TURN
ARROWS SEE STANDARD SHEET E-13

REVISIONS AND CORRECTIONS
MAY 3, 1982 - ADDED NOTE, CHANGED BORDER DIMENSION ON GUIDE SIGNS.

APPROVED:
Dec. 17, 1971

R.H. Arnold
CHIEF ENGINEER
E.V. Stickney
ASST. CHIEF ENGINEER
J.M. Lane
HIGHWAY ENGINEER

DRAWN A.W.C.
TRACED A.J.A.

TRAFFIC SIGNS (GUIDE SIGNS)
U.S. ROUTE MARKERS
AND AUXILIARY MARKERS



STANDARD
E-12