

3#1/2 FLANGED CHANNEL STEEL SIGN POST DETAIL

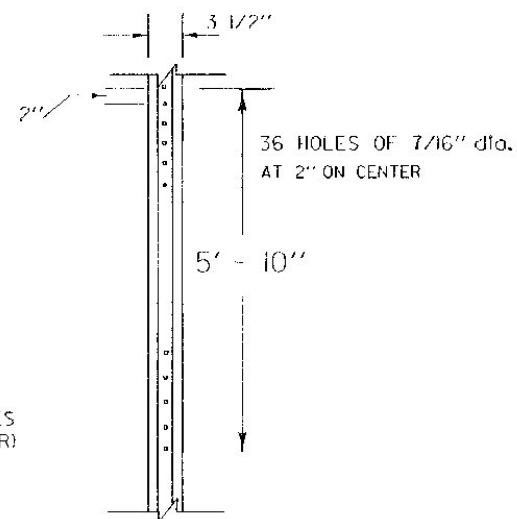

POST DRILLING DETAIL

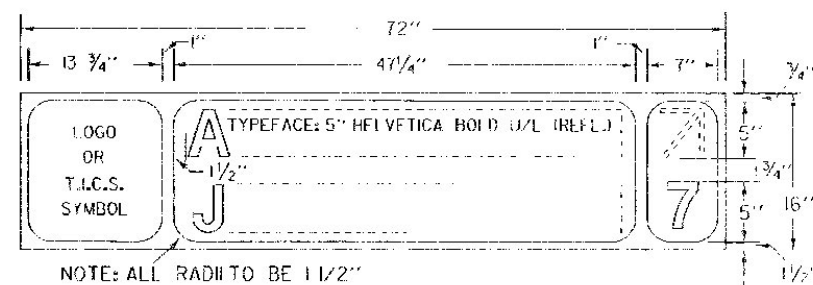

TYPE A

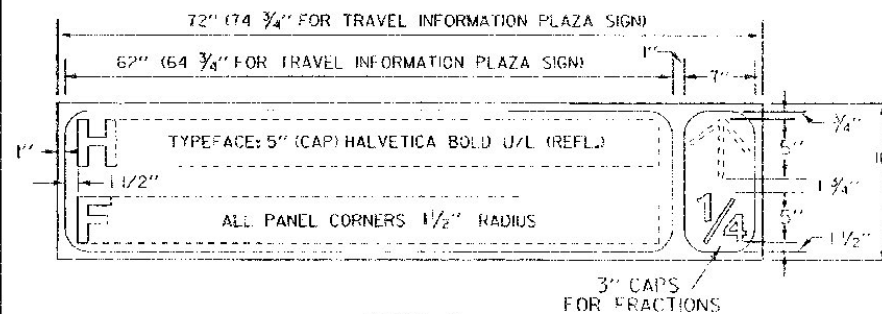

TYPE B

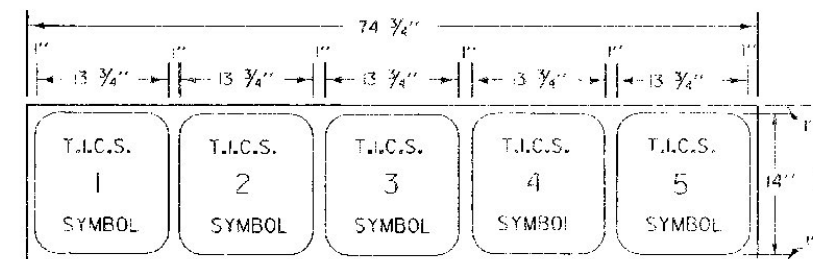

TYPE C

ONLY USED ON APPROACHES TO INFORMATION PLAZAS

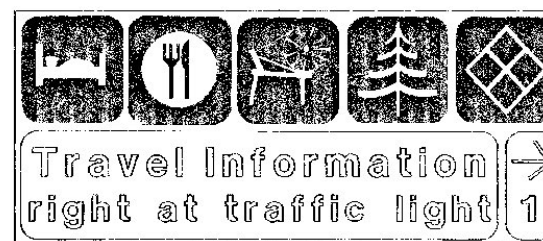

EXAMPLE OF PLAZA INFORMATION SIGN

FOR MORE DETAILS ON THE STATE'S INFORMATION SYSTEM, WRITE OR CALL: TRAVEL INFORMATION COUNCIL, C/O AGENCY OF TRANSPORTATION, MAINTENANCE DIVISION, NATIONAL LIFE BUILDING, MONTPELIER, VERMONT 05602 (802) 828-2651.

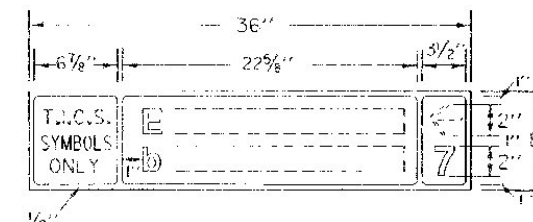

DIRECTIONAL SIGN DETAIL FOR USE ON HIGHWAYS WITH SPEEDS OF 30 M.P.H. OR LESS

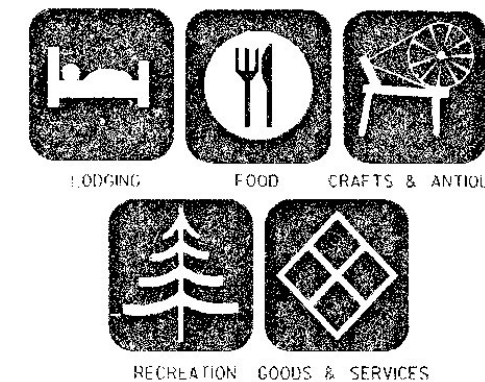

THE SYMBOLS ABOVE ARE FEATURED ON VERMONT'S TRAVEL INFORMATION PLAZAS, WHICH ARE FREE-STANDING OUTDOOR KIOSKS FOUND AT INTERSTATE REST AREAS, WELCOME CENTERS, AND NEAR KEY POINTS OF INTEREST. PLAZA LOCATIONS ARE INDICATED ON THE OFFICIAL STATE MAP BY THE SYMBOL 7.

MATERIALS:

SIGN BASE MATERIAL SHALL BE HIGH DENSITY OVERLAIN PLYWOOD, 3/8" THICK, WHICH HAS BEEN SEALED ON THE EDGES AND PAINTED BLACK. THE BACK OF THE SIGNBOARD SHALL ALSO BE PAINTED BLACK. EACH SIGNBOARD IS TO BE DRILLED WITH FOUR 7/8" HOLES. THE INTERIOR OF THE HOLES SHALL BE PAINTED OR OTHERWISE SEALED AGAINST THE WEATHER.

DIRECTIONAL ARROWS AND MILEAGE NUMBERS WILL BE MADE OF REFLECTORIZED MATERIAL. (ENGINEERING GRADE)

COLOR:

SIGNBOARD FACES WILL HAVE BLACK BACKGROUND WITH WHITE BORDER. T.I.C.S. SYMBOL BACKGROUNDS WILL BE COLORED AS FOLLOWS:

- LODGING - MAGENTA (PINK)
- FOOD - ORANGE
- CRAFTS & ANTIQUES - AQUA
- RECREATION - BROWN
- GOODS AND OTHER SERVICES - BLACK

ALL SYMBOLS WILL BE REFLECTORIZED.

TEXT LAYOUT:

NAME OF BUSINESS ENTERPRISE WILL BE IN UPPER AND LOWER CASE LETTERS STARTING FLUSH LEFT ON THE TOP LINE, AND MAY, ONLY WHEN NECESSARY, EXTEND TO THE SECOND LINE. (FLUSH LEFT ALSO). DIRECTIONAL INFORMATION WILL BE ALL IN LOWER CASE (NO CAPS), AND WILL ALWAYS BE ON THE SECOND LINE, EITHER FLUSH LEFT OR FOLLOWING THE END OF THE ESTABLISHMENT'S NAME.

OTHER STDS. E-160 REQUIRED:

REVISIONS AND CORRECTIONS

7/UG. 22, 1988 DATE OF ORIGINAL ISSUE
7/UG. 08, 1995 MINOR DETAIL AND NOTE REVISIONS

APPROVED

Stanley J. McCallister
DIRECTOR OF ENGINEERING

David A. Reed
TRAFFIC AND SAFETY ENGINEER

APPROVED FOR THIS PROJECT AND/OR DESIGN IMPLEMENTATION. FHWA FINAL APPROVAL PENDING.

TRAVEL INFORMATION COUNCIL SIGNS



STANDARD E-125