

**SIDE VIEW  
TYPE III BARRICADE**

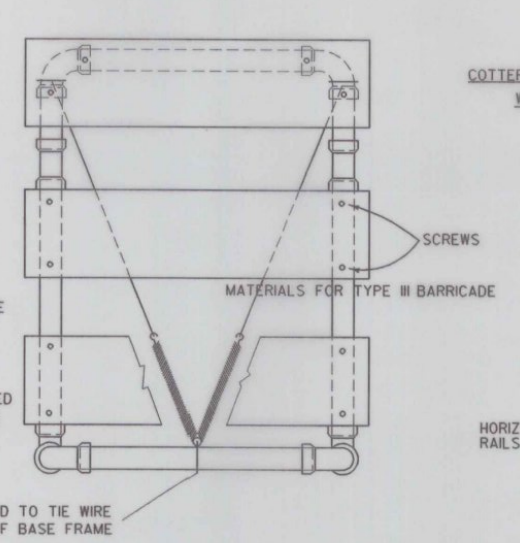

**FRONT VIEW  
TYPE III BARRICADE**

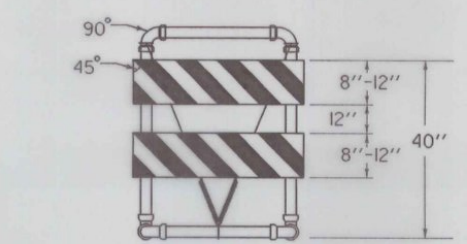
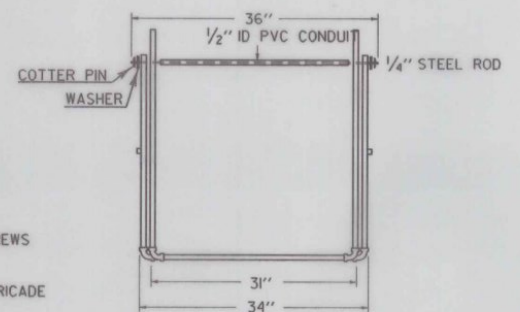

**TYPE III (MODIFIED) BARRICADE  
(STRIPING IS SHOWN WITH TRAFFIC PASSING TO THE RIGHT).**

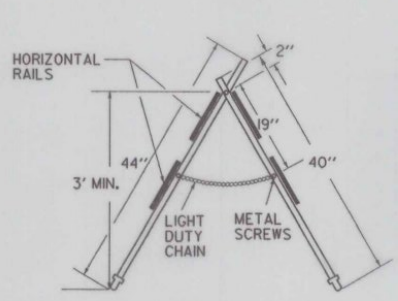

**TYPE I AND TYPE II BARRICADE**

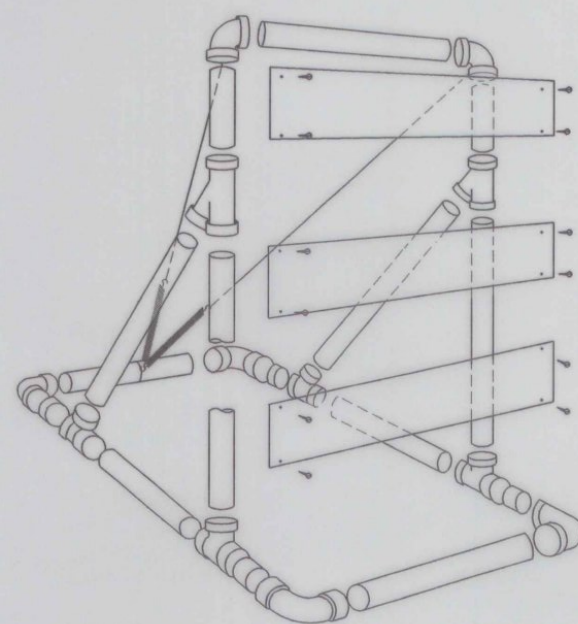

**EXPLODED VIEW  
TYPE III BARRICADE**

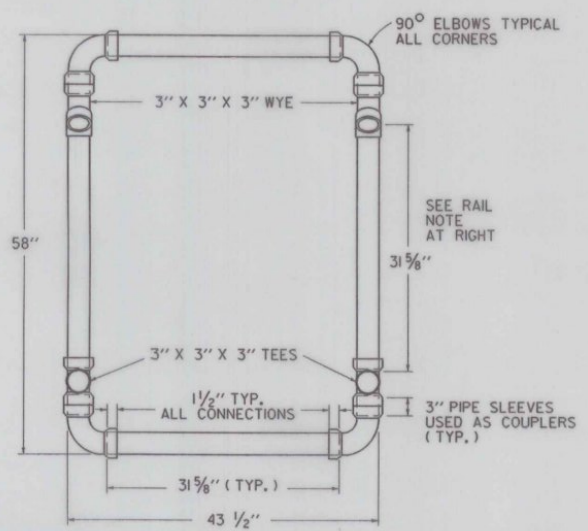

**TOP VIEW OF BASE  
TYPE III BARRICADE**

**MATERIALS FOR TYPE I AND II BARRICADES**

- 20' - 1" PVC
- 4 - 1" PVC 90° ELBOWS
- 30' - 1/2" ID THINWALL PVC CONDUIT
- 36' - 1/4" STEEL ROD
- 4 - 1" WASHERS
- 24' - LIGHT DUTY CHAIN
- 1/2" - #14 PAN HEAD METAL SCREWS (AS REQUIRED)
- 2 - 3/4" COTTER PINS
- 2 OR 4 - 8" OR 12" X 36" X 0.025" BARRICADE RAILS (AS REQUIRED)

**MATERIALS FOR TYPE III BARRICADES**

- 30' - 3" I.D. PVC PIPE
- 6 - 3" 90° ELBOWS
- 2 - 3" TEES
- 4 - 3" WYES
- 4 - 8" X 48" X 0.025" BARRICADE RAILS
- 2 - 5/8" X 11" #8 SPRING (IF ASSEMBLY IS NOT CEMENTED)
- 12 - 1" #14 PAN HEAD METAL SCREWS
- 15 LF - #14 BLACK ANNEALED TIE WIRE (IF ASSEMBLY IS NOT CEMENTED)

**MATERIALS**

THE PIPE, WYES, TEES AND ELBOWS USED TO CONSTRUCT BARRICADES SHALL CONFORM TO THE REQUIREMENTS OF ASTM DESIGNATION D 2241 FOR P.V.C. 1120 OR 1220 SDR-21, PRESSURE RATING 200 PSI. THE WYES, TEES AND ELBOWS SHALL CONFORM TO THE REQUIREMENTS OF ASTM DESIGNATION D 2466, TYPE II, GRADE I. ALL JOINTS SHALL BE SLIP-FIT AND MAY BE LIGHTLY CEMENTED. THE BARRICADE RAILS SHALL BE FABRICATED FROM 0.025" ALUMINUM AND SHALL HAVE REFLECTORIZED ALTERNATING ORANGE AND WHITE STRIPES (SLOPING DOWNWARD AT AN ANGLE OF 45 DEGREES IN THE DIRECTION TRAFFIC IS TO PASS).

**MAINTENANCE**

BARRICADES SHALL BE MAINTAINED IN CLEAN AND LEGIBLE CONDITIONS SATISFACTORY TO THE ENGINEER. THEY SHALL BE COMPLETELY VISIBLE TO APPROACHING TRAFFIC AT ALL TIMES. DAMAGED, DEFACED, OR DIRTY BARRICADES SHALL BE REPAIRED, CLEANED OR REPLACED AS ORDERED BY THE ENGINEER. THE P.V.C. PIPE AND FITTINGS SHALL BE WHITE IN COLOR. AT LEAST TWO (2) HOLES SHALL BE DRILLED (3/8" DIAM.) IN EACH SECTION OF PIPE AND FITTINGS IF THE ASSEMBLY IS NOT CEMENTED.

BARRICADES SHALL BE STABILIZED WITH SAND BAGS OF MINIMUM WEIGHT WHICH WILL NOT CONSTITUTE A HAZARD IF THE BARRICADE IS HIT. THESE SHALL BE PLACED ONLY ON THE FRONT AND REAR PIPES OF THE BASE FRAME OF THE BARRICADE. SAND BAG STABILIZERS SHALL BE SO PLACED AS NOT TO BE A HAZARD TO VEHICLES PASSING ON EITHER SIDE. GLUED JOINTS MAY PROVIDE ADDITIONAL STABILITY TO THE INSTALLATION.

TYPE I BARRICADES SHALL UTILIZE ONE HORIZONTAL RAIL IN EACH DIRECTION.

TYPE II BARRICADES SHALL BE A TYPE I BARRICADE WITH AN ADDITIONAL HORIZONTAL RAIL MOUNTED BELOW THE OTHER IN EACH DIRECTION.

TYPE III BARRICADES (MODIFIED) SHALL CONSIST OF THE BREAKAWAY 3" PVC DESIGN SHOWN ON THIS SHEET WITH THE TWO RAIL LAYOUT DETAILED ABOVE LEFT.

SEE STD E-107 FOR ADDITIONAL INFORMATION.

**NOTES:**

- 1) REFER TO STANDARD TYPE III BARRICADE (ABOVE LEFT) FOR DIMENSIONS
- 2) ALL BARRICADE JOINTS SHALL BE GLUED.
- 3) FIVE SAND BAGS ARE REQUIRED BOTH FRONT AND BACK, 50 LB. MINIMUM EACH.

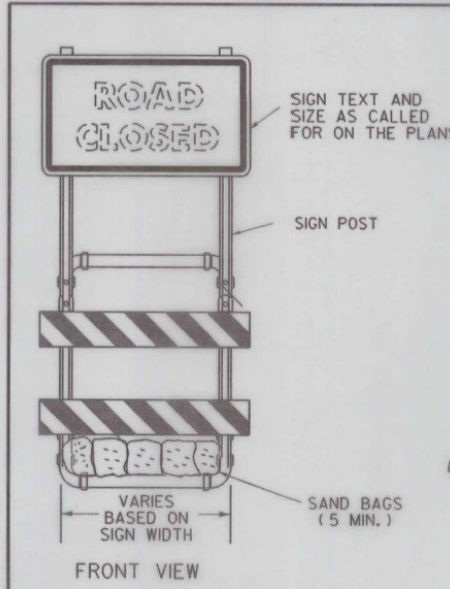

**SIGN MOUNTING ON  
TYPE III BARRICADE (MODIFIED)**

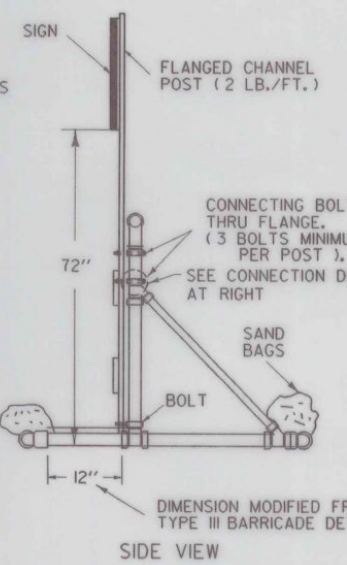

**SIDE VIEW**

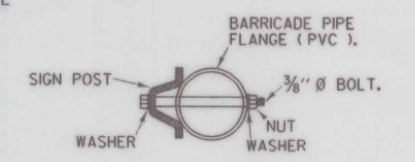

**CONNECTION DETAIL**

**OTHER STDS. : E-107  
REQUIRED**

REVISIONS AND CORRECTIONS  
SEPT. 20, 1993 - REVISED NOTES AND TYPE III (MOD.) BARRICADE DETAIL

APPROVED \_\_\_\_\_ DATE SEPT. 10, 1987  
\_\_\_\_\_  
DIRECTOR OF ENGINEERING  
\_\_\_\_\_  
Acting TRAFFIC AND SAFETY ENGINEER

APPROVED FOR THIS PROJECT AND/OR DESIGN IMPLEMENTATION. FHWA FINAL APPROVAL PENDING.

**BREAKAWAY BARRICADE  
DETAILS**



**STANDARD  
E-107a**