

SIDE VIEW
TYPE III BARRICADE

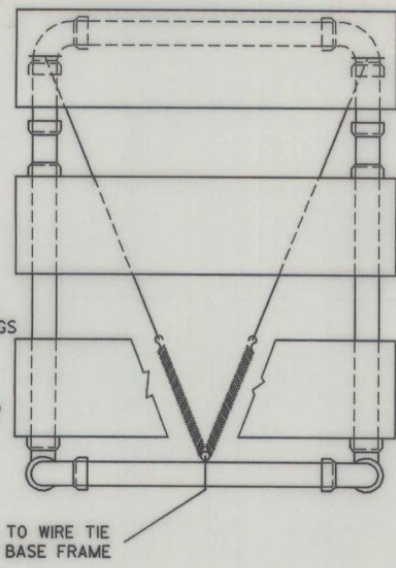

FRONT VIEW
TYPE III BARRICADE

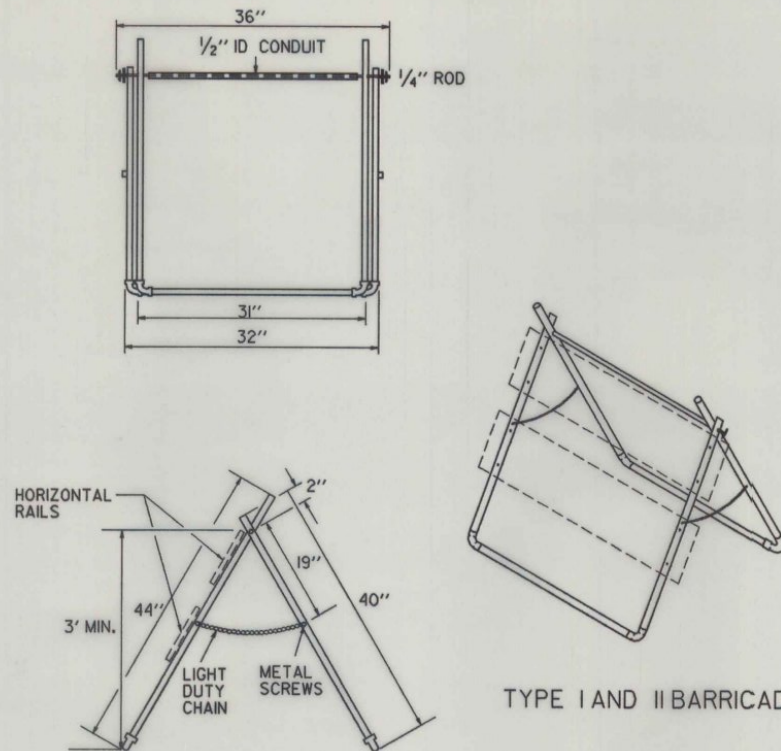

TYPE I AND II BARRICADE DETAILS

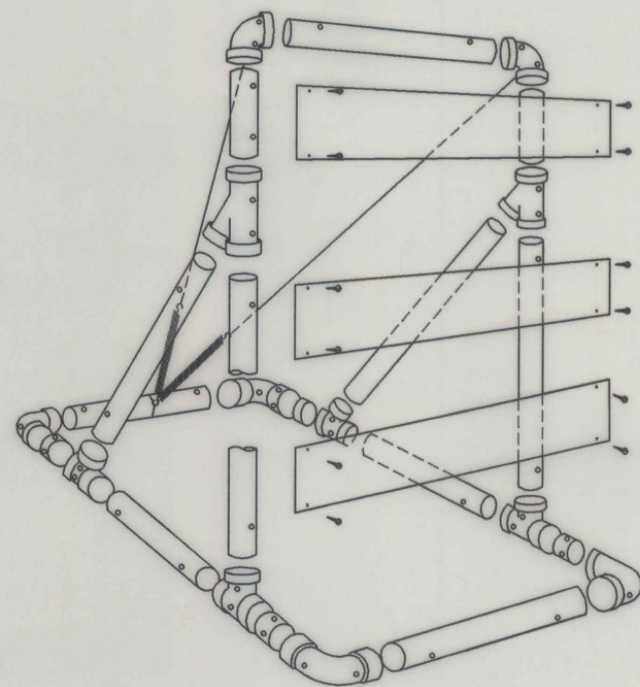

TYPE III BARRICADE ASSEMBLY
EXPLODED VIEW

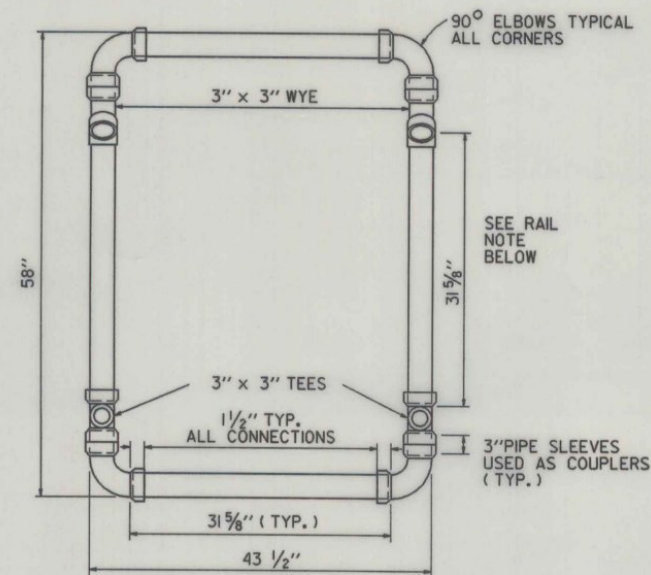

TYPE III BARRICADE
TOP VIEW OF
BASE

MATERIALS FOR TYPE I AND II BARRICADES

- 20' - 1" PVC
- 4 - 1" PVC 90° ELBOWS
- 30" - 1/2" ID THINWALL CONDUIT
- 36" - 1/4" STEEL ROD
- 4 - 1" WASHERS
- 24" - LIGHT DUTY CHAIN
- 4 - METAL SCREWS
- 2 - 3/4" COTTER PINS

MATERIALS FOR TYPE III BARRICADE

- 30' - 3" I.D. PVC PIPE
- 6 - 3/4" BENT ELBOWS
- 2 - 3" TEES
- 4 - 3" WYES
- 4 - 8" x 48" x 0.25" BARRICADE RAILS
- 2 - 5/8" x 11" # 8 SPRING
- 12 - 1" # 14 PANHEAD METAL SCREWS
- 15 - # 14 BLACK ANNEALED TIE WIRE

MATERIALS

THE PIPE, WYES, TEES AND ELBOWS USED TO CONSTRUCT BARRICADES SHALL CONFORM TO THE REQUIREMENTS OF ASTM DESIGNATION D 2241 FOR P.V.C. 1120 OR 1220 SDR-21, PRESSURE RATING 200 PSI. THE WYES, TEES AND ELBOWS SHALL CONFORM TO THE REQUIREMENTS OF ASTM DESIGNATION D 2466, TYPE II, GRADE I. ALL JOINTS SHALL BE SLIP-FIT AND MAY BE LIGHTLY CEMENTED. THE BARRICADE RAILS SHALL BE FABRICATED FROM 0.025" ANODIZED ALUMINUM AND SHALL HAVE REFLECTORIZED ALTERNATING ORANGE AND WHITE STRIPS (SLOPING DOWNWARD AT AN ANGLE OF 45 DEGREES IN THE DIRECTION TRAFFIC IS TO PASS).

MAINTENANCE

BARRICADES SHALL BE MAINTAINED IN CLEAN AND LEGIBLE CONDITIONS SATISFACTORY TO THE ENGINEER. THEY SHALL BE COMPLETELY VISIBLE TO APPROACHING TRAFFIC AT ALL TIMES. DAMAGED, DEFACED, OR DIRTY BARRICADES SHALL BE REPAIRED, CLEANED OR REPLACED AS ORDERED BY THE ENGINEER. THE P.V.C. PIPE AND FITTINGS SHALL BE WHITE IN COLOR. AT LEAST TWO (2) HOLES SHALL BE DRILLED (3/16") IN EACH SECTION OF PIPE AND FITTINGS IF THE ASSEMBLY IS NOT CEMENTED.

BARRICADES SHALL BE STABILIZED WITH SAND BAGS OF MINIMUM WEIGHT WHICH WILL NOT CONSTITUTE A HAZARD IF THE BARRICADE IS HIT. THESE SHALL BE PLACED ONLY IN THE BASE FRAME OF THE BARRICADE. STABILIZERS SHALL BE SO PLACED AS NOT TO BE A HAZARD TO VEHICLES PASSING ON EITHER SIDE. IF BARRICADE REPLACEMENT COSTS CAN BE CONSIDERED NEGLIGIBLE, GLUED JOINTS MAY PROVIDE ADDITIONAL STABILITY TO THE INSTALLATION.

TYPE I BARRICADES SHALL UTILIZE ONE HORIZONTAL RAIL.

TYPE II BARRICADES SHALL CONSIST OF AN ADDITIONAL HORIZONTAL RAIL MOUNTED BELOW THE OTHER.

TYPE III BARRICADES (MODIFIED) SHALL CONSIST OF THE BREAKAWAY 3" PVC DESIGN SHOWN ON THIS SHEET WITH THE TWO RAIL LAYOUT DETAILED BELOW.

SEE STD E-107 FOR ADDITIONAL INFORMATION.

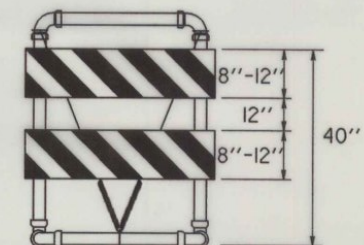

TYPE III (MODIFIED) BARRICADE
(STRIPING DOWN WHERE TRAFFIC PASSES ON RIGHT).

SEE STANDARD E-107 FOR RAIL DETAILS.
RAILS ATTACHED WITH 1" NO. 14 PAN HEAD METAL SCREW.

REVISIONS AND CORRECTIONS

APPROVED

SEPT. 10, 1987
DATE
David B. Kelley
CHIEF ENGINEER
Arthur Goss
DIRECTOR OF PLANNING
AND PRE-CONSTRUCTION
Stephen B. MacArthur
TRAFFIC AND SAFETY ENGINEER

BREAKAWAY BARRICADE DETAILS



STANDARD E-107a